

Annex F

Floating Docks Surveying and Replacement Design 2024

Reference Documents Drawings and Components List



Reference Drawing List

Note: The drawings provided correspond to the original works and are to be used as a guide only.

General

61/01/01/T1	Title Sheet
61/01/01/T2	General Notes
61/01/01/T3	Standard Barge Units
61/01/01/T4	Standard Barge Attachments
61/01/01/T5	Standard Aluminium Platforms
61/01/01/T6	Standard Aluminium Gangways & Ramps

Hamilton Terminal

13/26/02/HT2	Site Plan
13/26/02/HT3	Barge Assembly Plan
13/26/02/HT4	Aluminium Assembly Plan
13/26/02/HT5	Assembly Connection Details
13/26/02/HT6	Ballasting Plan
13/26/02/HT8	Wall Notch Construction
13/26/02/HT10	Gangway Pier Extension
13/26/02/HT11	Wall Fender
13/26/02/HT12	Mooring Piles
13/26/02/HT13	Misc. Details

Dockyard Terminal

61/45/01/DY1	Existing Conditions
61/45/01/DY3	Barge & Aluminum Assembly Plan
61/45/01/DY4	Assembly Connections
61/45/01/DY5	Ballasting Plan
61/45/01/DY6	Gangway Notch Plan & Details
61/45/01/DY7	Wall Fender
61/45/01/DY8	Not Included
61/45/01/DY9	Fender Details
61/45/01/DY10	Misc. Details

61/45/01/DY11 Mooring Layout

61/45/01/DY12 Mooring Details

Market Wharf

61/46/01/SG2 Site Layout

61/46/01/SG3 Barge & Aluminium Assembly Plan

61/46/01/SG4 Assembly Connections

61/46/01/SG5 Ballasting Plan

Hamilton Depot

61/35/01/HD3 Barge Assembly Plan

S00 General Arrangement Plan

MINISTRY OF WORKS AND ENGINEERING



REPLACEMENT FERRY PROJECT
 PHASE 1
 DOCK CONSTRUCTION
 PROJECT NO. 61/01/01
 MAY 2001

REFERENCE ONLY

THE MINISTRY OF
 WORKS AND
 ENGINEERING

P.O. Box HM525 Hamilton HMCX Bermuda
 Phone: (441)295-5151

ENGINEERING and
 OPERATIONS DIVISION
 Fax: (441)295-0170

Structures Section



GENERAL NOTES:

ISSUED FOR: REFERENCE ONLY 2016 09 07

AMENDMENTS:			
NO:	REVISION	APP	DATE:
B	NOTES	RRB	04/01/02
C	REFERENCE ONLY	MAM	2016 09 07

SCALE: NO SCALE

SURVEY	
PREPARED BY:	DATE:
RRB	23/05/01
DESIGN	
PREPARED BY:	DATE:
RRB	23/05/01
CHECKED BY:	DATE:
RRB	23/05/01
DRAWING	
PREPARED BY:	DATE:
RRB	23/05/01
CHECKED BY:	DATE:
RRB	23/05/01
APPROVED BY:	RRB

PROJECT NUMBER:
 61/01/01

PROJECT NAME:
**REPLACEMENT FERRY PROJECT
 PHASE I
 DOCK CONSTRUCTION**

DRAWING FILE NO: ACAD R-14
 TITLE SHT REV.dwg

SHEET TITLE:
TITLE SHEET

SHEET NUMBER:	REVISION
61/01/01/T1	A

DRAWING LIST		
DRAWING #	TITLE	CURRENT REVISION
GENERAL DRAWINGS		
T1	TITLE SHEET	B
T2	GENERAL NOTES	B
T3	STANDARD BARGE UNITS	B
T4	STANDARD BARGE ATTACHMENTS	B
T5	STANDARD ALUMINUM PLATFORMS	--
T6	STANDARD ALUMINUM GANGWAYS & RAMPS	--
HAMILTON DEPOT		
HD1	EXISTING CONDITIONS	--
HD2	SITE LAYOUT	B
HD3	BARGE ASSEMBLY PLAN	B
HD4	ALUMINUM ASSEMBLY PLAN	B
HD5	ASSEMBLY CONNECTIONS	B
HD6	BALLASTING PLAN	B
HD7	PIER PILE & PILE CAP PLAN	A
HD8	PIER PILE CAP DETAILS	--
HD9	STRUCTURE ALTERNATIVES	--
HD10	MISCELLANEOUS CONCRETE DETAILS	B
HD11	WALL AND VESSEL FENDER	A
HD12	MOORING PILES	B
HD13	MISC. DETAILS	B

DRAWING LIST		
DRAWING #	TITLE	CURRENT REVISION
HAMILTON TERMINAL		
A1	PROPOSED LAYOUT PLAN AND ELEVATION	B
A2	LANDSIDE WORKS - ALTERATIONS TO EXISTING	A
A3	LANDSIDE WORKS - PLAN AND ELEVATION	A
A4	LANDSIDE WORKS - SECTIONS AND DETAILS	A
HT1	EXISTING CONDITIONS	--
HT2	SITE PLAN	B
HT3	BARGE ASSEMBLY PLAN	B
HT4	ALUMINUM ASSEMBLY PLAN	B
HT5	ASSEMBLY CONNECTION DETAILS	B
HT6	BALLASTING PLAN	B
HT7	CANOPY	--
HT8	WALL NOTCH CONSTRUCTION	--
HT9	WALL DETAILS	--
HT10	GANGWAY PIER EXTENSION	--
HT11	WALL FENDER	--
HT12	MOORING PILES	B
HT13	MISC. DETAILS	B
DOCKYARD		
DY1	EXISTING CONDITIONS	--
DY2	**SHEET DELETED**	B
DY3	BARGE & ALUMINUM ASSEMBLY PLAN	B
DY4	ASSEMBLY CONNECTIONS	B
DY5	BALLASTING PLAN	B
DY6	GANGWAY NOTCH PLAN & DETAILS	--
DY7	WALL FENDER	--
DY8	**SHEET DELETED**	B
DY9	FENDER DETAILS	B
DY10	MISC. DETAILS	B
DY11	MOORING LAYOUT	B
DY12	MOORING DETAILS	B

DRAWING LIST		
DRAWING #	TITLE	CURRENT REVISION
ST. GEORGE'S		
SG1	EXISTING CONDITIONS	--
SG2	SITE LAYOUT	B
SG3	BARGE & ALUMINUM ASSEMBLY PLAN	B
SG4	ASSEMBLY CONNECTION	B
SG5	BALLASTING PLAN	B
SG6	PIER PLAN AND DETAILS	--
SG7	MOORING PILES	B
SG8	MISC. DETAILS	B
SG9	PLAN, SECTIONS AND DETAILS	--
ROCKAWAY TERMINAL		
RW1	EXISTING CONDITIONS	--
RW2	SITE LAYOUT	--
RW3	ACCESS RAMP PLAN & ELEVATION	B
RW4	ACCESS RAMP REINFORCING DETAILS	A
RW5	OUTSHORE PLATFORM AND SUSPENDED SLAB	--
RW6	PIER PLAN & ELEVATIONS	--
RW7	PIER PILE/PILECAP PLAN & ELEVATIONS	--
RW8	PILE & PILE CAP DETAILS	--
RW9	SHEETING ELEVATION & DETAILS	--
RW10	PIER STRUCTURE ALTERNATIVES	--
RW11	PIER NOTCH PLAN & ELEVATIONS	--
RW12	PIER ATTACHMENT DETAILS	--
RW13	BERTHING DOLPHINS	--
RW14	DOLPHIN DETAILS	--
RW15	GANGWAY HOIST PLAN & DETAILS	--
RW16	DOLPHIN ASSEMBLY PLANS & DETAILS	B
RW17	MISC. DETAILS	--

Reference Drawings

Structures Section

BCE Bourne Consulting Engin
104 West Central Street
Franklin, MA 02038
TEL: (603) 538-8133 FAX: (603) 538-0011

GENERAL NOTES:
WTBH - WATER TIGHT BULKHEAD

ISSUED FOR: REFERENCE ONLY 2016 09 07

AMENDMENTS:

NO:	REVISION	APP	DATE:
B	REVISIONS AS NOTED	RRB	04/01/02
C	REFERENCE ONLY	MAM	2016 09 07

SCALE: AS NOTED

SURVEY

PREPARED BY:	DATE:
BAP	23/05/01
CHECKED BY:	DATE:
RRB	23/05/01

DESIGN

PREPARED BY:	DATE:
JSK	23/05/01
CHECKED BY:	DATE:
RRB	23/05/01

APPROVED BY:

RRB

PROJECT NUMBER:

61/01/01

PROJECT NAME:

REPLACEMENT FERRY PROJECT
PHASE 1
DOCK CONSTRUCTION

DRAWING FILE NO: ACAD R-14
T-3 STD Barge Units.dwg

SHEET TITLE:
STANDARD
BARGE UNITS

SHEET NUMBER: 61/01/01/T3

REVISION
A

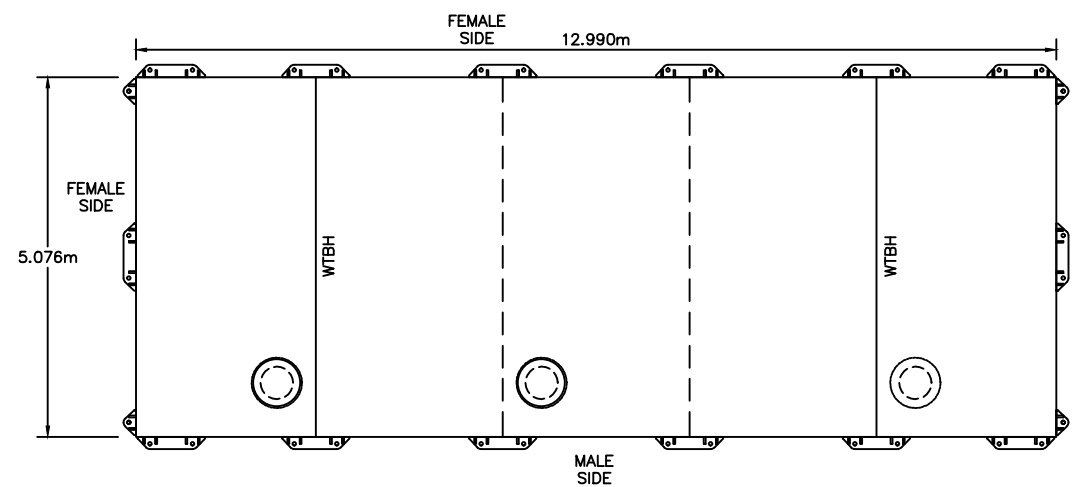

APPROXIMATE WEIGHT
PER FABRICATOR: 58,388 lbs

A
T3
TYPE I BARGE
SCALE: 1 : 50

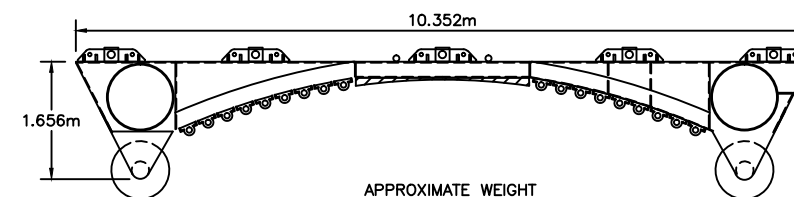
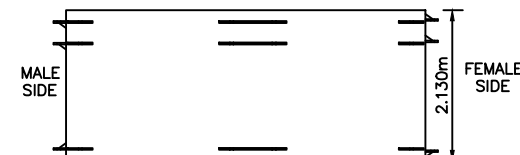

APPROXIMATE WEIGHT
PER FABRICATOR: 28,500 lbs

B
T3
BOW LOADER UNIT
SCALE: 1 : 50

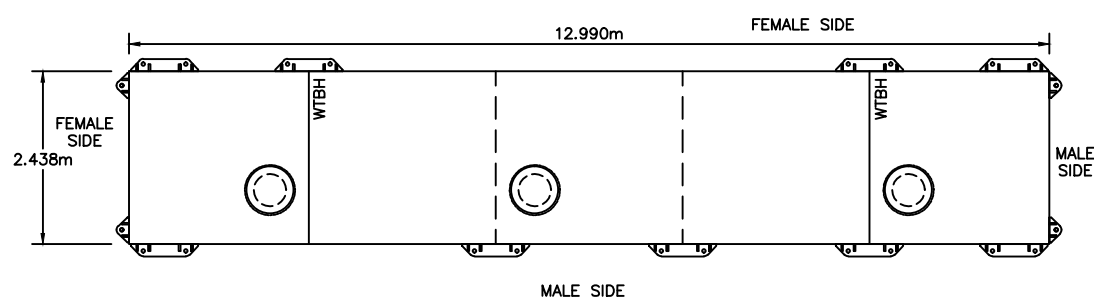

APPROXIMATE WEIGHT
PER FABRICATOR: 36,476 lbs

C
T3
TYPE II BARGE
SCALE: 1 : 50

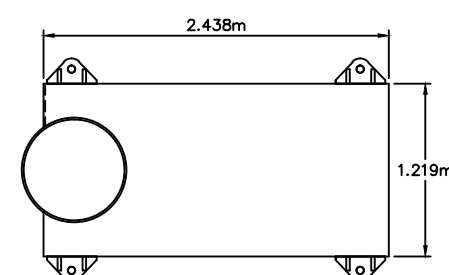
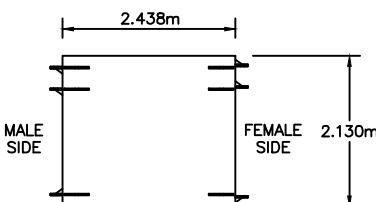

APPROXIMATE WEIGHT
PER FABRICATOR: 4,950 lbs

D
T3
TYPE I PILE GUIDE
SCALE: 1 : 25

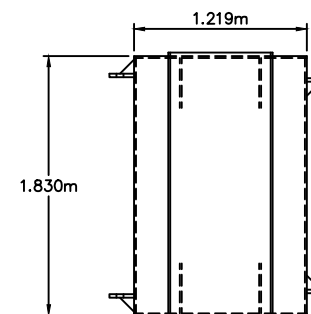

REFERENCE ONLY

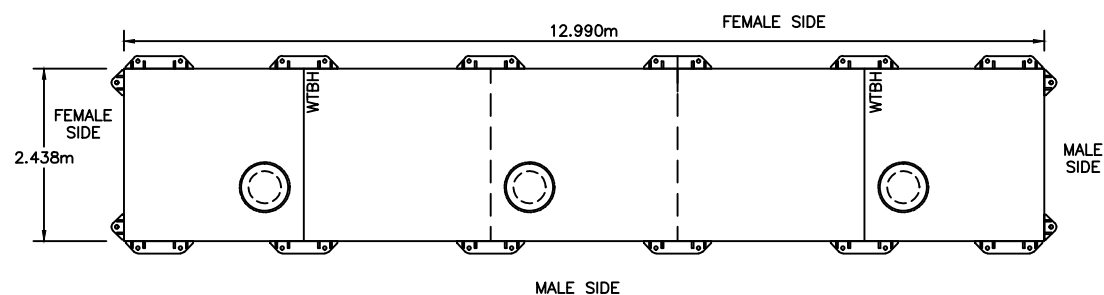

APPROXIMATE WEIGHT
PER FABRICATOR: 32,802 lbs

E
T3
TYPE III BARGE
SCALE: 1 : 50

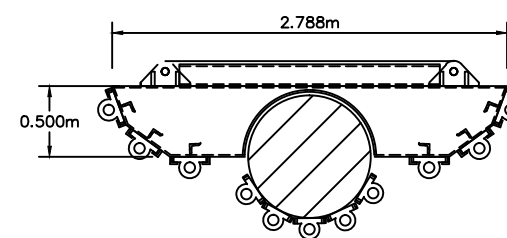
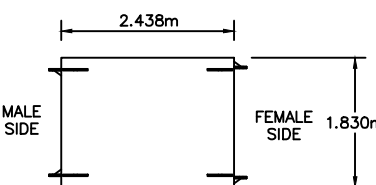

APPROXIMATE WEIGHT: 5,890 lbs
PER FABRICATOR: 5,434 lbs

G
T3
TYPE II PILE GUIDE
SCALE: 1 : 25

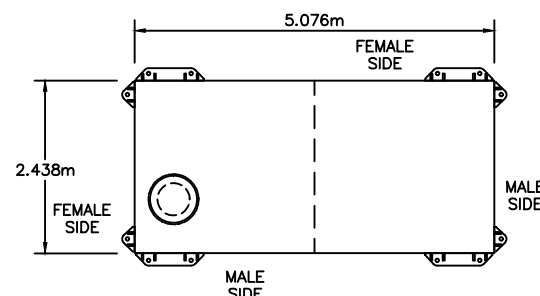
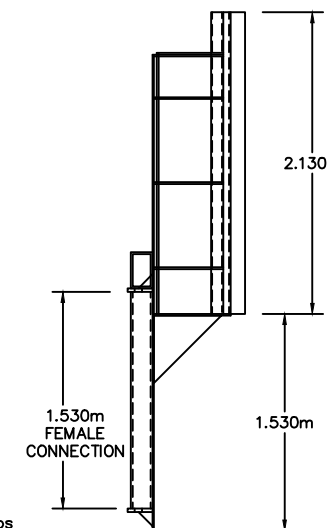

APPROXIMATE WEIGHT
PER FABRICATOR: 13,948 lbs

F
T3
TYPE IV BARGE
SCALE: 1 : 50

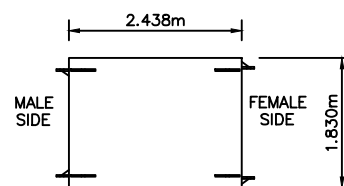

Reference Drawings

GENERAL NOTES:

ISSUED FOR: REFERENCE ONLY 2016 09 07

AMENDMENTS:

NO:	REVISION	APP	DATE:
△	HIGH HMS FENDER	RRB	04/01/02
△	REFERENCE ONLY	MAM	2016 09 07

SCALE: AS NOTED

SURVEY

PREPARED BY: DATE:

DESIGN

PREPARED BY: BAP DATE: 23/05/01
CHECKED BY: RRB DATE: 23/05/01

DRAWING

PREPARED BY: JSK DATE: 23/05/01
CHECKED BY: RRB DATE: 23/05/01

APPROVED BY:
RRB

PROJECT NUMBER:
61/01/01

PROJECT NAME:

REPLACEMENT FERRY PROJECT
PHASE 1
DOCK CONSTRUCTION

DRAWING FILE NO: ACAD R-14
T-4 STD Barge Attachments.dwg

SHEET TITLE:

STANDARD
BARGE ATTACHMENTS

SHEET NUMBER: 13/01/01/T4 REVISION:

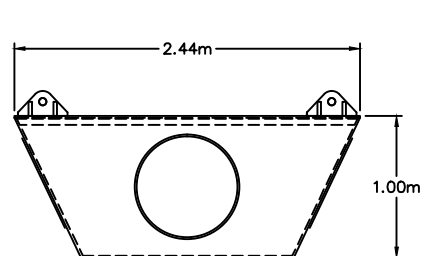

2 PINS REQ'D-LENGTH VARIES

A
T4
TYPE III PILE GUIDE
SCALE: 1 : 25

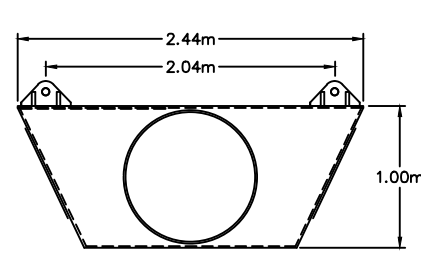
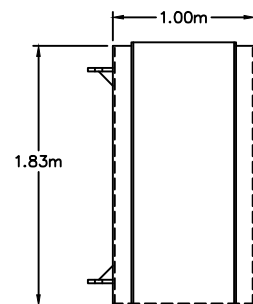

2 LONG PINS REQ'D

B
T4
TYPE IV PILE GUIDE
SCALE: 1 : 25

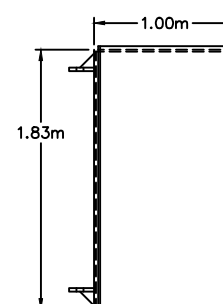

C
T4
WALL FENDER
SCALE: 1 : 25

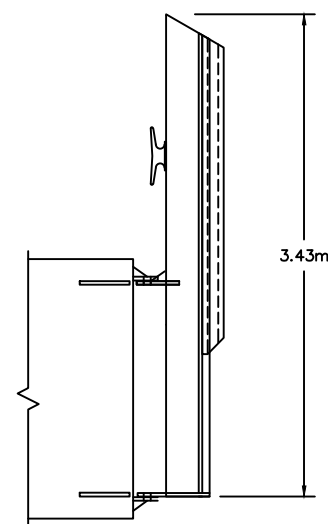
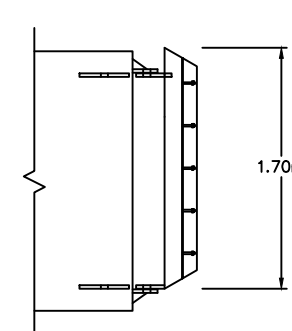

D
T4
2 SHORT PINS REQ'D
HIGH FENDER TYPE HM
SCALE: 1 : 25

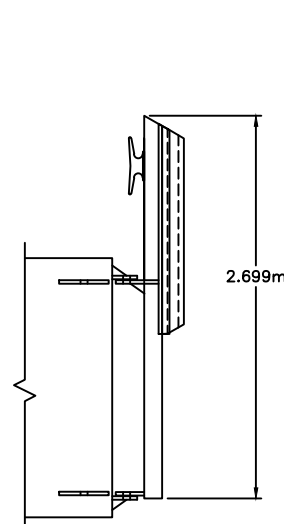

E
T4
2 SHORT PINS REQ'D
LOW FENDER TYPE LM
SCALE: 1 : 25

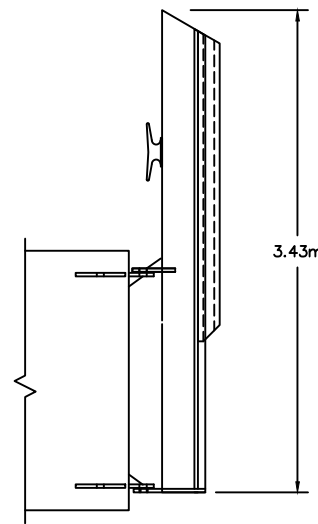

F
T4
2 SHORT PINS REQ'D
HIGH FENDER TYPE HF
SCALE: 1 : 25

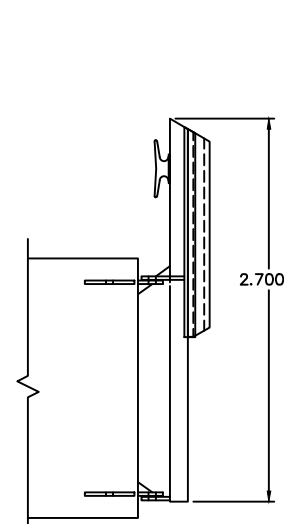

G
T4
2 SHORT PINS REQ'D
LOW FENDER TYPE LF
SCALE: 1 : 25

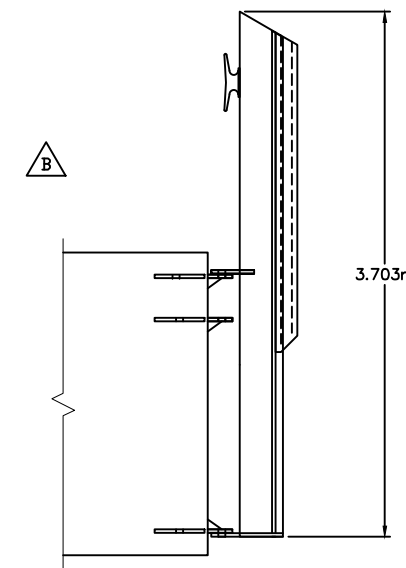

H
T4
2 LONG PINS REQ'D
HIGH FENDER TYPE HMS
SCALE: 1 : 25

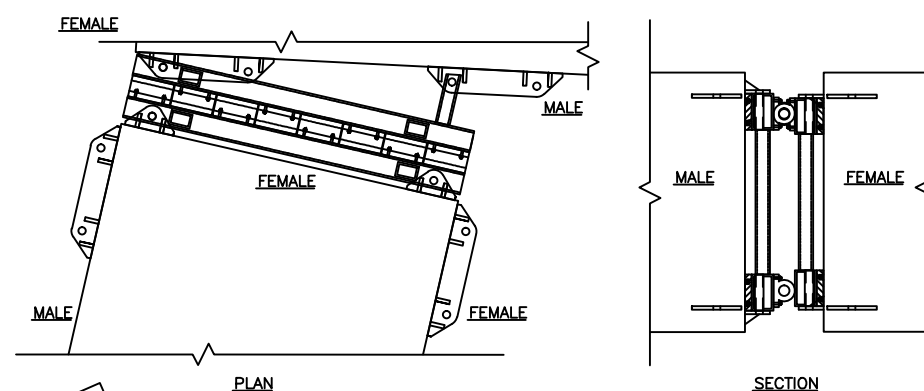

I
T4
BARGE CONNECTION - DETAIL
SCALE: 1 : 25

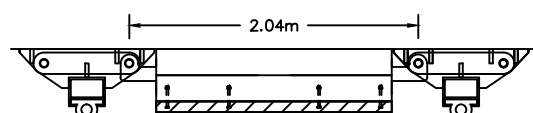

J
T4
TRANSITION ASSEMBLY
SCALE: 1 : 25

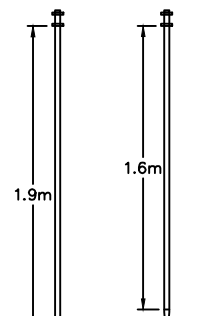
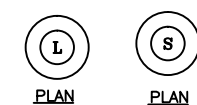

K
T4
PIN DETAIL
SCALE: 1 : 20

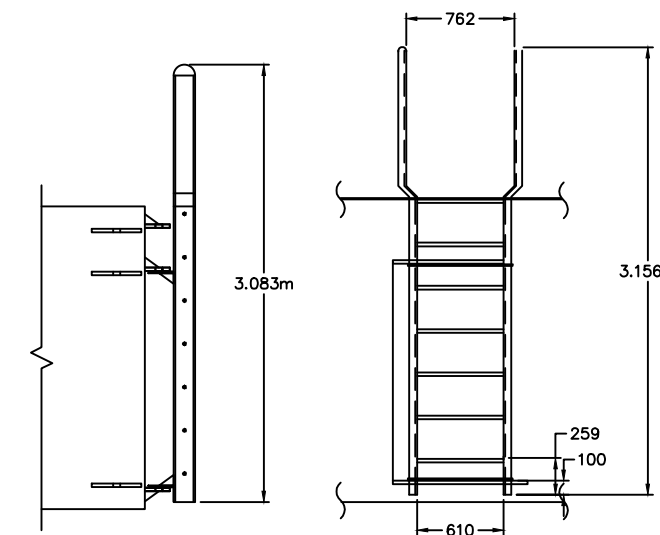

L
T4
LADDER
SCALE: 1 : 25

Reference Drawings

REFERENCE ONLY

Structures Section

GENERAL NOTES:

ISSUED FOR: REFERENCE ONLY 2016 09 07

AMENDMENTS:

NO:	REVISION	APP	DATE:

SCALE: 1 : 50

SURVEY

PREPARED BY: DATE:

DESIGN

PREPARED BY: DATE:
BAP 23/05/01
CHECKED BY: DATE:
RRB 23/05/01

DRAWING

PREPARED BY: DATE:
JSK 23/05/01
CHECKED BY: DATE:
RRB 23/05/01

APPROVED BY:
RRB

PROJECT NUMBER:
61/01/01

PROJECT NAME:

REPLACEMENT FERRY PROJECT
PHASE 1
DOCK CONSTRUCTION

DRAWING FILE NO: ACAD R-14
T-5 STD Aluminum Platforms.dwg

SHEET TITLE:

STANDARD ALUMINUM
PLATFORMS

SHEET NUMBER: REVISION
61/01/01/T5

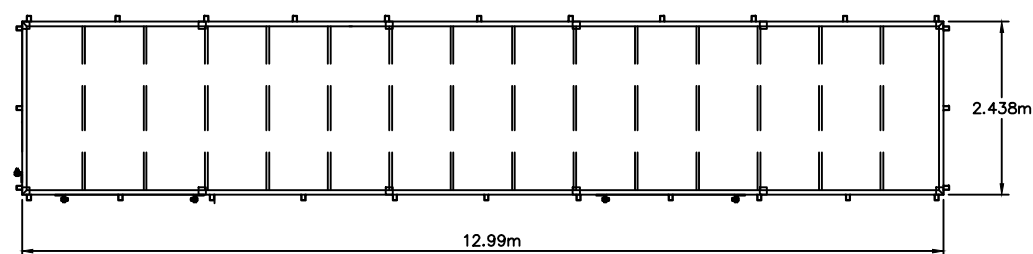

A
T5
TYPE A PLATFORM
SCALE: 1 : 50

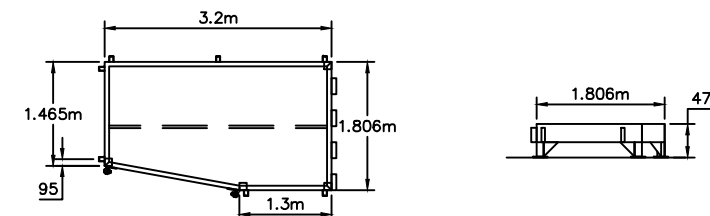
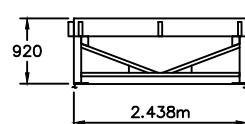

B
T5
HT-TYPE 2 PLATFORM
SCALE: 1 : 50

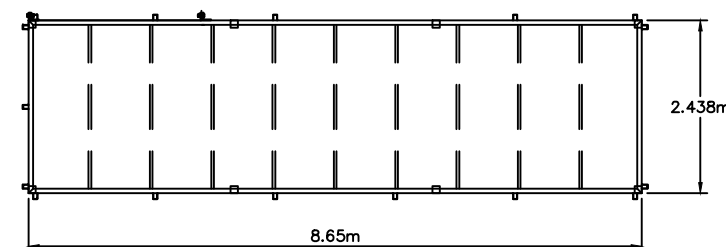

C
T5
TYPE B PLATFORM
SCALE: 1 : 50

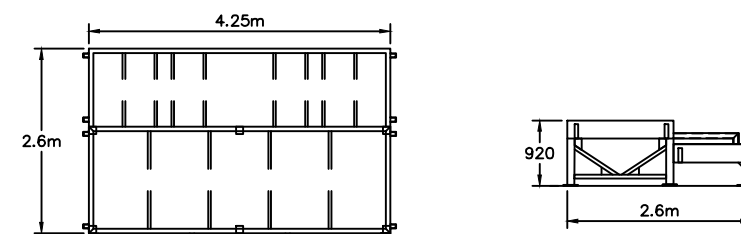
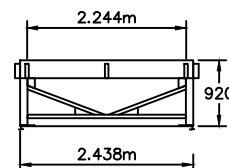

D
T5
DY-TYPE 1 PLATFORM
SCALE: 1 : 50

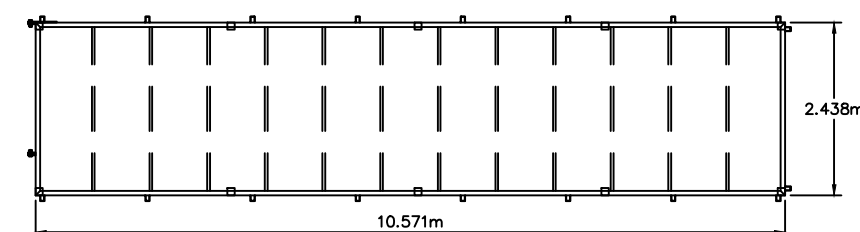

E
T5
HD-TYPE 1 PLATFORM
SCALE: 1 : 50

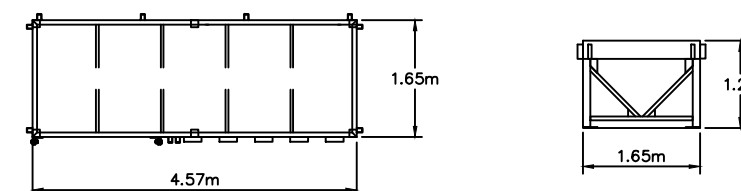
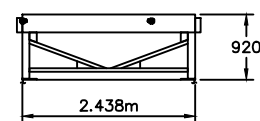

F
T5
DY-TYPE 2 PLATFORM
SCALE: 1 : 50

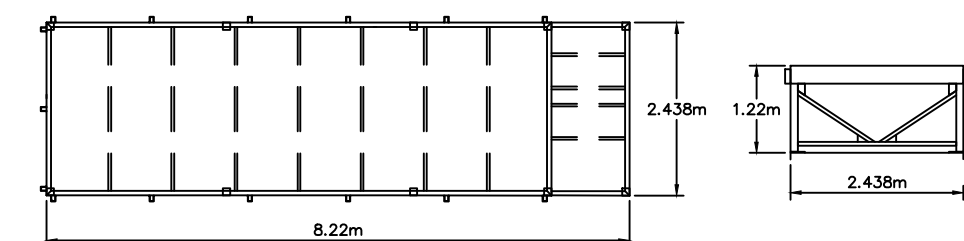

G
T5
HD-TYPE 2 PLATFORM
SCALE: 1 : 50

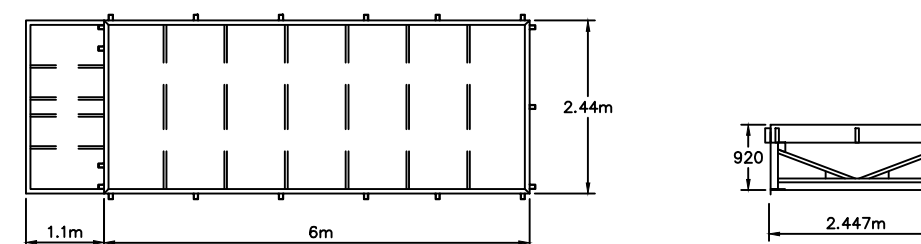

H
T5
StG-TYPE 1 PLATFORM
SCALE: 1 : 50

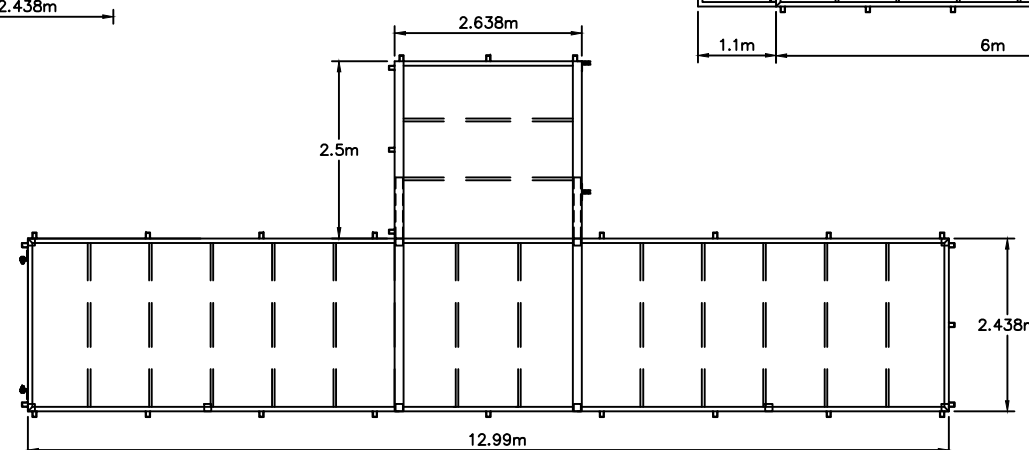

I
T5
HT-TYPE 1 PLATFORM
SCALE: 1 : 50

REFERENCE ONLY

Reference Drawings

Structures Section



GENERAL NOTES:

ISSUED FOR: REFERENCE ONLY 2016 09 07

AMENDMENTS:

NO.	REVISION	APP	DATE:

SCALE: 1 : 25

SURVEY

PREPARED BY: DATE:

DESIGN

PREPARED BY: BAP DATE: 23/05/01

CHECKED BY: RRB DATE: 23/05/01

DRAWING

PREPARED BY: JSK DATE: 23/05/01

CHECKED BY: RRB DATE: 23/05/01

APPROVED BY: RRB

PROJECT NUMBER: 61/01/01

PROJECT NAME:

REPLACEMENT FERRY PROJECT
PHASE 1
DOCK CONSTRUCTION

DRAWING FILE NO: ACAD R-14

SHEET TITLE:

STANDARD ALUMINUM
GANGWAYS & RAMPS

SHEET NUMBER: REVISION

61/01/01/T6

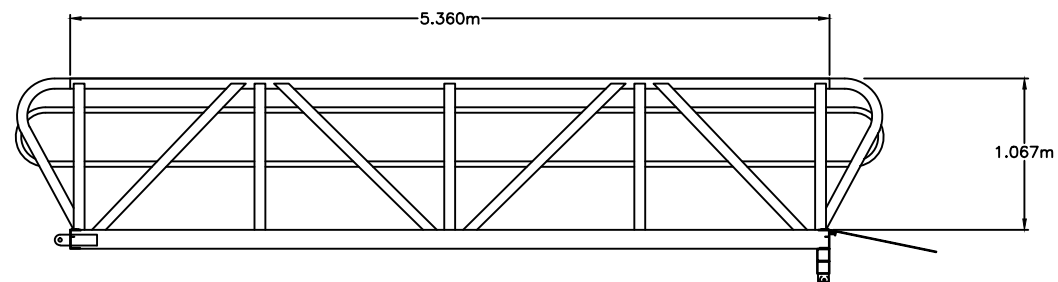

A TYPE I GANGWAY - ELEVATION
T6 SCALE: 1 : 25

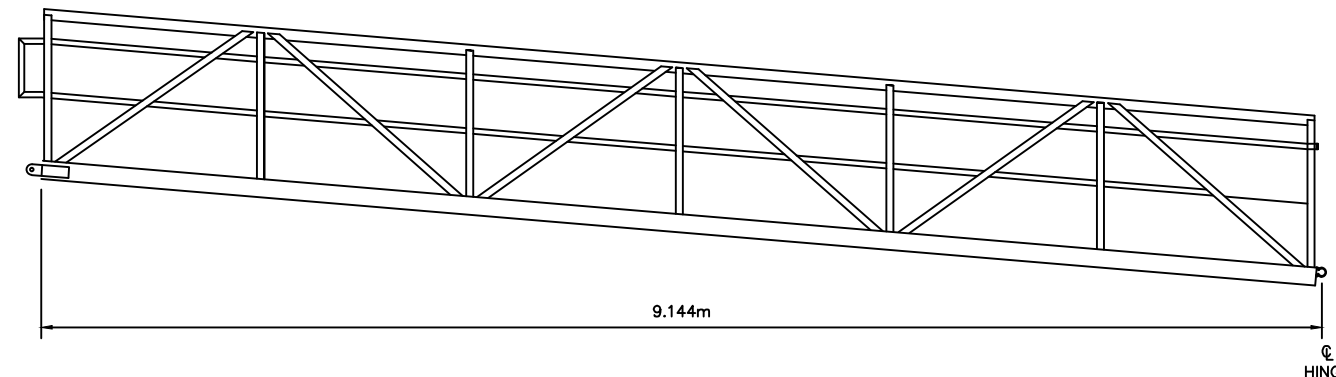

B TYPE A RAMP-ELEVATION
T6 SCALE: 1 : 25

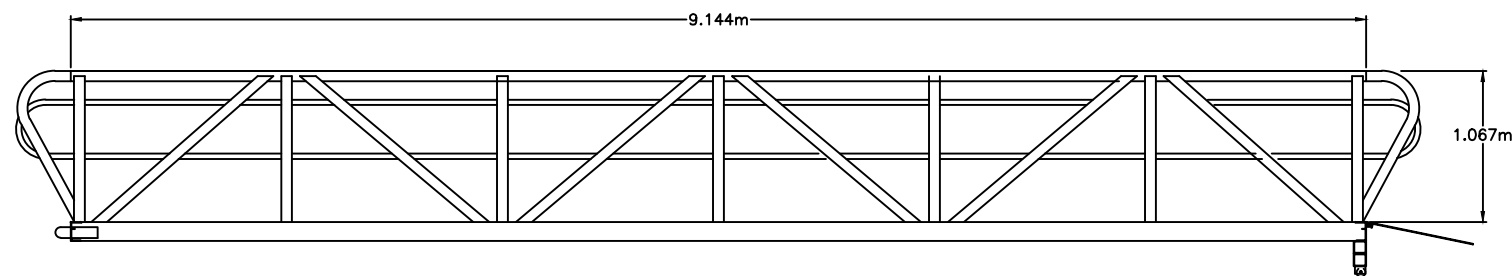

C TYPE II GANGWAY - ELEVATION
T6 SCALE: 1 : 25

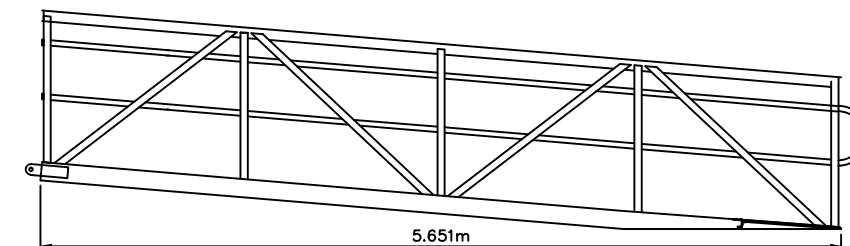

D HT-TYPE 1 RAMP-ELEVATION
T6 SCALE: 1 : 25

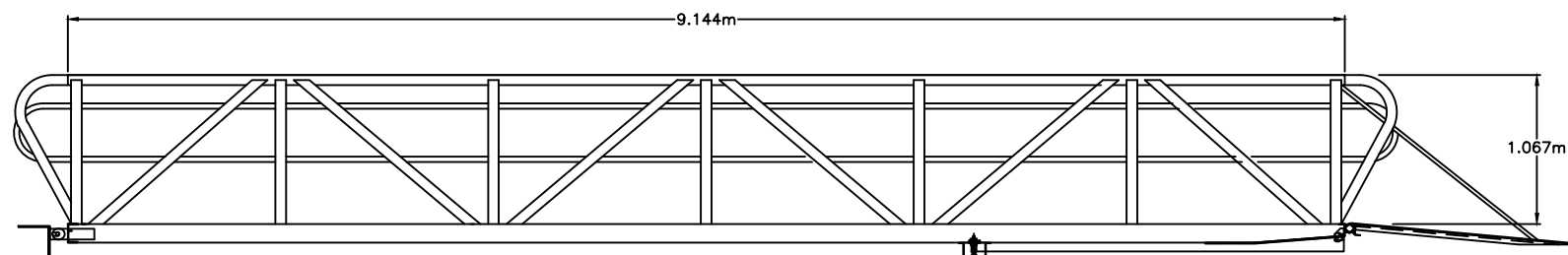

E TYPE III GANGWAY - ELEVATION
T6 SCALE: 1 : 25

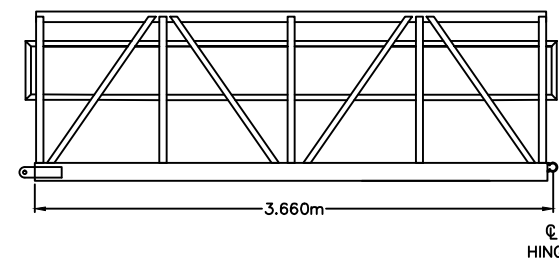

F DY-TYPE 1 RAMP-ELEVATION
T6 SCALE: 1 : 25

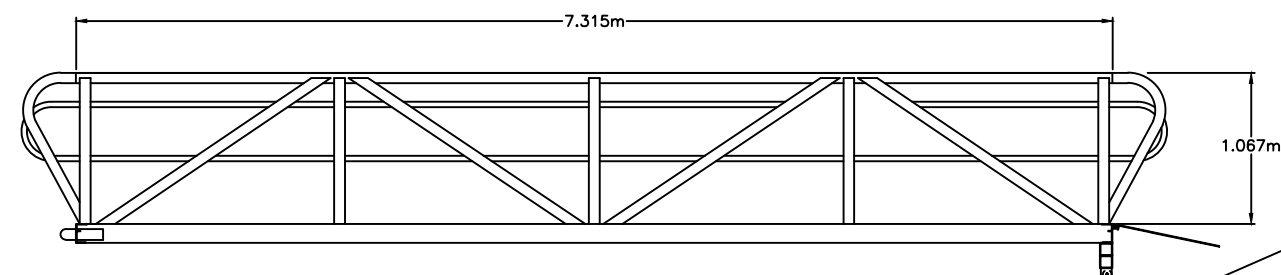

G TYPE IV GANGWAY - ELEVATION
T6 SCALE: 1 : 25

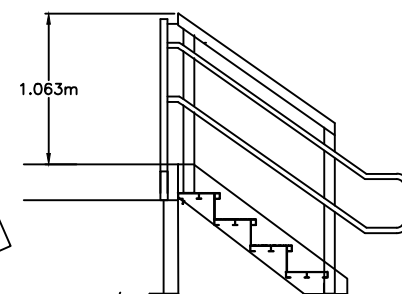

H STAIRS
T6 SCALE: 1 : 25

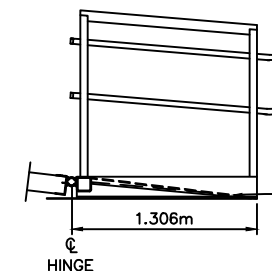

I TRANSITION RAMP-ELEVATION
T6 SCALE: 1 : 25

REFERENCE ONLY

Reference Drawings

Structures Section



- GENERAL NOTES:
- COORDINATES BASED ON BNG 2000.
 - ALL ELEVATIONS ARE IN METERS BASED ON ORDNANCE DATUM.
 - ALL DISTANCES ARE IN METERS.
 - SURVEY CONTROL SHALL BE PROVIDED TO THE CONTRACTOR BY THE OWNER.

ISSUED FOR: CONSTRUCTION 14/08/01

AMENDMENTS:

NO:	REVISION	APP	DATE:
Δ	BARGES II & IV	RRB	04/01/02

SCALE: 1 : 100

SURVEY
PREPARED BY: DATE:

DESIGN
PREPARED BY: DATE: 23/05/01
BAP
CHECKED BY: DATE: 23/05/01
RRB

DRAWING
PREPARED BY: DATE: 23/05/01
JSK
CHECKED BY: DATE: 23/05/01
RRB

APPROVED BY:
RRB
PROJECT NUMBER:
61/01/01

PROJECT NAME:
**HAMILTON TERMINAL
REPLACEMENT FERRY PROJECT
PHASE 1
DOCK CONSTRUCTION**

**#1 POINT PLEASANT ROAD
PEMBROKE PARISH**
DRAWING FILE NO: ACAD R-14
HT-4_Site-Layout.dwg

SHEET TITLE:
**SITE
PLAN**

SHEET NUMBER: 3/26/02/HT2 REVISION: Δ

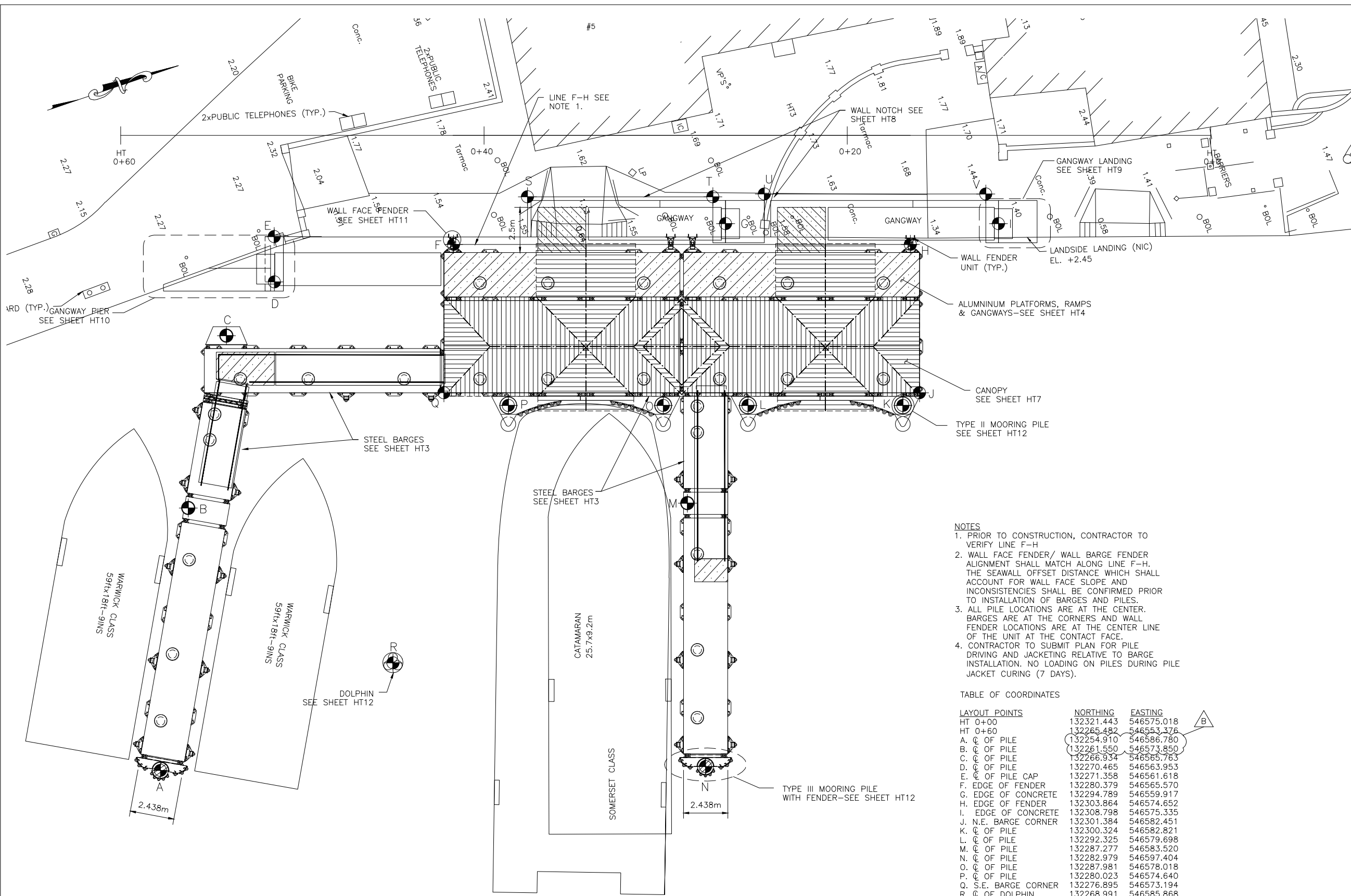

- NOTES
- PRIOR TO CONSTRUCTION, CONTRACTOR TO VERIFY LINE F-H
 - WALL FACE FENDER/ WALL BARGE FENDER ALIGNMENT SHALL MATCH ALONG LINE F-H. THE SEAWALL OFFSET DISTANCE WHICH SHALL ACCOUNT FOR WALL FACE SLOPE AND INCONSISTENCIES SHALL BE CONFIRMED PRIOR TO INSTALLATION OF BARGES AND PILES.
 - ALL PILE LOCATIONS ARE AT THE CENTER. BARGES ARE AT THE CORNERS AND WALL FENDER LOCATIONS ARE AT THE CENTER LINE OF THE UNIT AT THE CONTACT FACE.
 - CONTRACTOR TO SUBMIT PLAN FOR PILE DRIVING AND JACKETING RELATIVE TO BARGE INSTALLATION. NO LOADING ON PILES DURING PILE JACKET CURING (7 DAYS).

TABLE OF COORDINATES

LAYOUT POINTS	NORTHING	EASTING
HT 0+00	132321.443	546575.018
HT 0+60	132265.482	546553.376
A. C. OF PILE	132254.910	546586.780
B. C. OF PILE	132261.550	546573.850
C. C. OF PILE	132266.934	546565.763
D. C. OF PILE	132270.465	546563.953
E. C. OF PILE CAP	132271.358	546561.618
F. EDGE OF FENDER	132280.379	546565.570
G. EDGE OF CONCRETE	132294.789	546559.917
H. EDGE OF FENDER	132303.864	546574.652
I. EDGE OF CONCRETE	132308.798	546575.335
J. N.E. BARGE CORNER	132301.384	546582.451
K. C. OF PILE	132300.324	546582.821
L. C. OF PILE	132292.325	546579.698
M. C. OF PILE	132287.277	546583.520
N. C. OF PILE	132282.979	546597.404
O. C. OF PILE	132287.981	546578.018
P. C. OF PILE	132280.023	546574.640
Q. S.E. BARGE CORNER	132276.895	546573.194
R. C. OF DOLPHIN	132268.991	546585.868
S. COR. OF CONCRETE	132285.149	546564.603
T. COR. OF CONCRETE	132294.670	546568.285
U. COR. OF CONCRETE	132297.365	546569.167
V. COR. OF CONCRETE	132308.732	546573.563

GENERAL LAYOUT PLAN

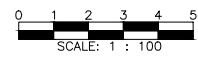

⊙ A - LAYOUT POINT

Reference Drawings

CONSTRUCTION

Structures Section



- GENERAL NOTES:
1. COORDINATES BASED ON BNG 2000.
 2. ALL ELEVATIONS ARE IN METERS BASED ON ORDNANCE DATUM.
 3. ALL DISTANCES ARE IN METERS.
 4. SURVEY CONTROL SHALL BE PROVIDED TO THE CONTRACTOR BY THE OWNER.

ISSUED FOR: CONSTRUCTION 14/08/01

AMENDMENTS:

NO:	REVISION	APP	DATE:
A	BARGES II & IV	RRB	04/01/02

SCALE: 1 : 100

SURVEY
PREPARED BY: DATE:

DESIGN
PREPARED BY: DATE: 23/05/01
BAP
CHECKED BY: DATE: 23/05/01
RRB

DRAWING
PREPARED BY: DATE: 23/05/01
JSK
CHECKED BY: DATE: 23/05/01
BAP

APPROVED BY:
RRB

PROJECT NUMBER:
61/01/01

PROJECT NAME:
HAMILTON TERMINAL
REPLACEMENT FERRY PROJECT
PHASE 1
DOCK CONSTRUCTION

#1 POINT PLEASANT ROAD
PEMBROKE PARISH

DRAWING FILE NO: ACAD R-14
HT-3_Barge-assembly.dwg

SHEET TITLE:
BARGE ASSEMBLY
PLAN

SHEET NUMBER:
13/26/02/HT3

REVISION
B

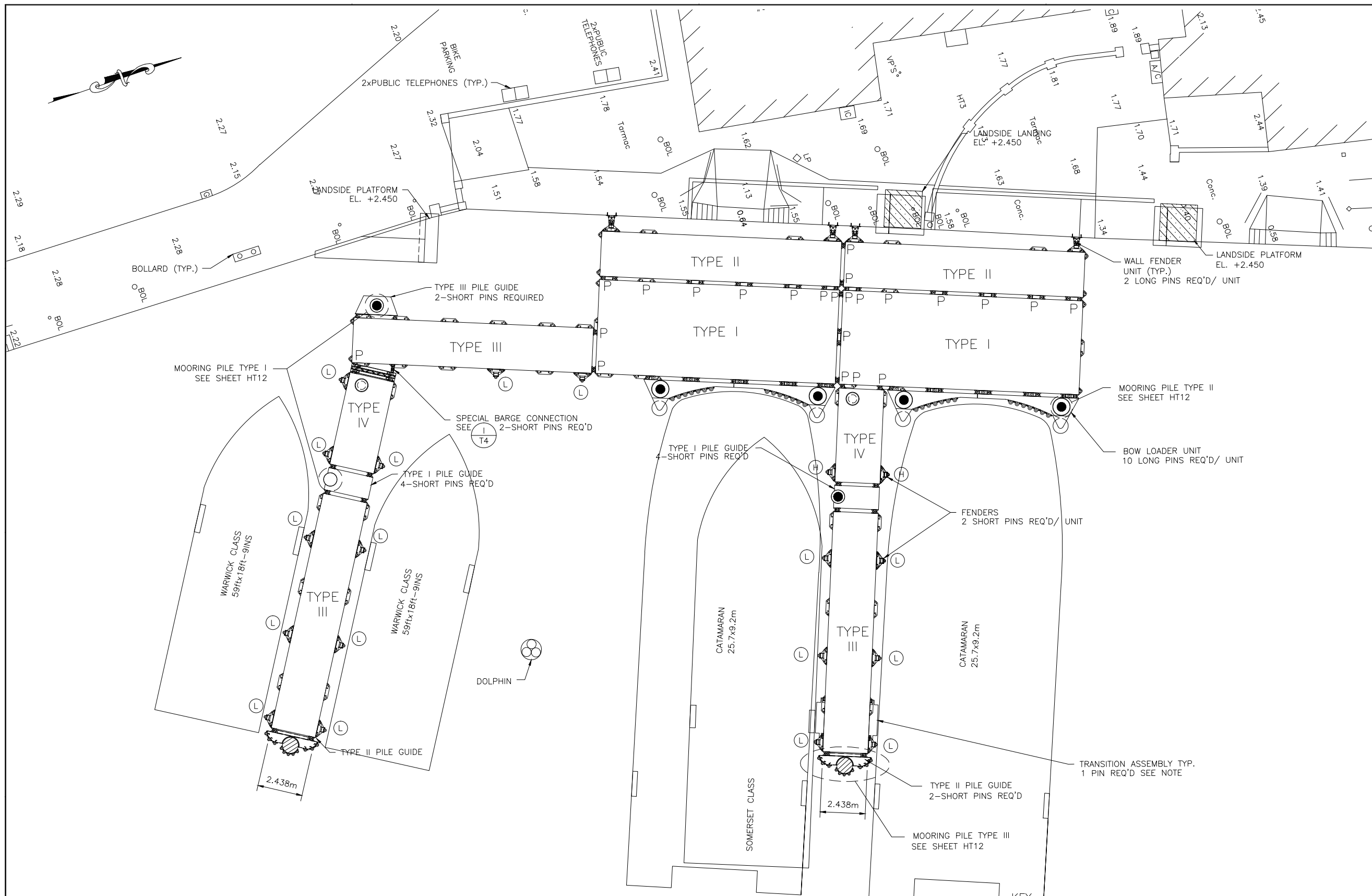

BARGE LAYOUT

- (L) LOW FENDER - SEE SHEET T4.
- (H) HIGH FENDER - SEE SHEET T4.
- P-BARGE TO BARGE PIN REQUIRED

- NOTE:
1. SEE SHEETS T3 FOR BARGE UNITS.
 2. SEE SHEETS T4 FOR PILE GUIDE UNITS.
 3. TRANSITION ASSEMBLY TO USE COMMON PIN W/ BARGE FENDER.

CONSTRUCTION

Reference Drawings



Structures Section



GENERAL NOTES:

1. COORDINATES BASED ON BNG 2000.
2. ALL ELEVATIONS ARE IN METERS BASED ON ORDNANCE DATUM.
3. ALL DISTANCES ARE IN METERS.
4. SURVEY CONTROL SHALL BE PROVIDED TO THE CONTRACTOR BY THE OWNER.

ISSUED FOR: CONSTRUCTION 14/08/01

AMENDMENTS:

NO:	REVISION	APP	DATE:
A	BARGES II & IV	RRB	04/01/02

SCALE: 1 : 100

SURVEY

PREPARED BY: DATE:

DESIGN

PREPARED BY: BAP DATE: 23/05/01
CHECKED BY: RRB DATE: 23/05/01

DRAWING

PREPARED BY: JSK DATE: 23/05/01
CHECKED BY: BAP DATE: 23/05/01

APPROVED BY:
RRB

PROJECT NUMBER:
61/01/01

PROJECT NAME:
**HAMILTON TERMINAL
REPLACEMENT FERRY PROJECT
PHASE 1
DOCK CONSTRUCTION**

**#1 POINT PLEASANT ROAD
PEMBROKE PARISH**

DRAWING FILE NO: ACAD R-14
HT-4_Alum-Assembly.dwg

SHEET TITLE:
**ALUMINUM
ASSEMBLY PLAN**

SHEET NUMBER: 13/26/02/HT4
REVISION: A

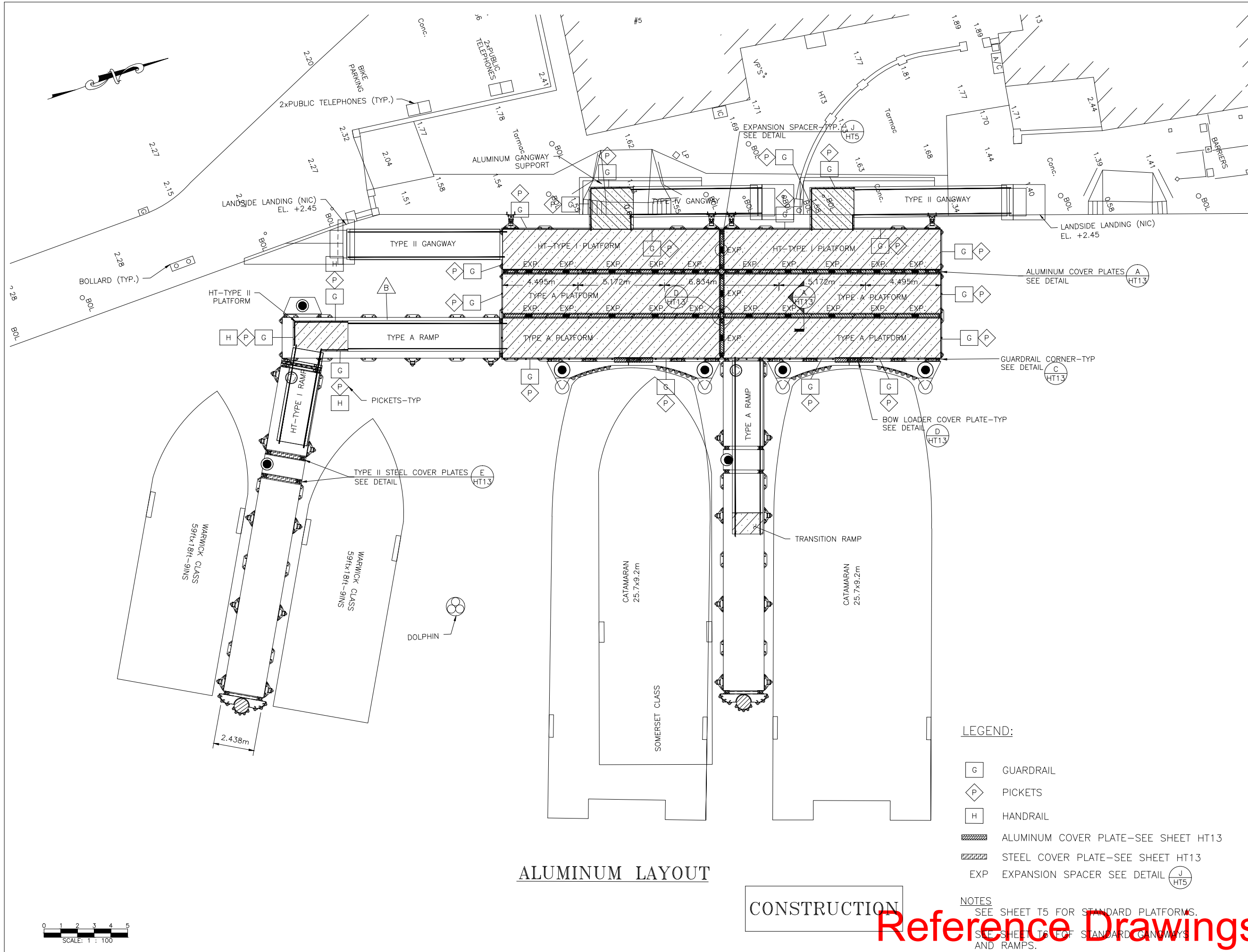

LEGEND:

- G GUARDRAIL
- P PICKETS
- H HANDRAIL
- ALUMINUM COVER PLATE-SEE SHEET HT13
- STEEL COVER PLATE-SEE SHEET HT13
- EXP EXPANSION SPACER SEE DETAIL

NOTES
SEE SHEET T5 FOR STANDARD PLATFORMS.
SEE SHEET T6 FOR STANDARD GANGWAYS
AND RAMPS.

CONSTRUCTION

Reference Drawings



Structures Section

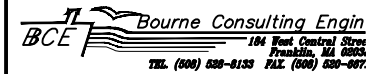

GENERAL NOTES:

ISSUED FOR: CONSTRUCTION 14/08/01

AMENDMENTS:

NO:	REVISION	APP	DATE:
Δ	REVISED AS NOTED	RRB	04/01/02

SCALE: AS NOTED

SURVEY

PREPARED BY: DATE:

DESIGN

PREPARED BY: BAP DATE: 23/05/01

CHECKED BY: RRB DATE: 23/05/01

DRAWING

PREPARED BY: JSK DATE: 23/05/01

CHECKED BY: BAP DATE: 23/05/01

APPROVED BY: RRB

PROJECT NUMBER:

61/01/01

PROJECT NAME:

HAMILTON TERMINAL
REPLACEMENT FERRY PROJEC
PHASE 1
DOCK CONSTRUCTION

#1 POINT PLEASANT ROAD
PEMBROKE PARISH

DRAWING FILE NO: ACAD R-14
HT-5 Assembly-Connections.dwg

SHEET TITLE:

ASSEMBLY
CONNECTION DETAILS

SHEET NUMBER: 13/26/02/HT5

REVISION

Δ

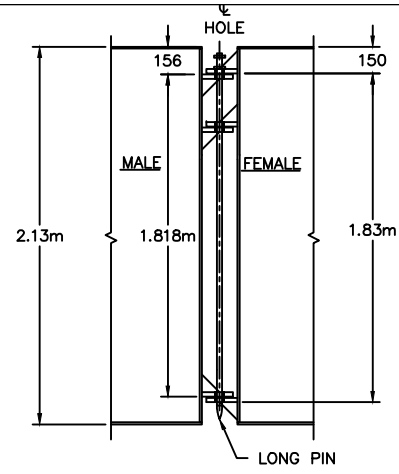

A HIGH BARGE CONNECTION

SCALE: 1 : 20

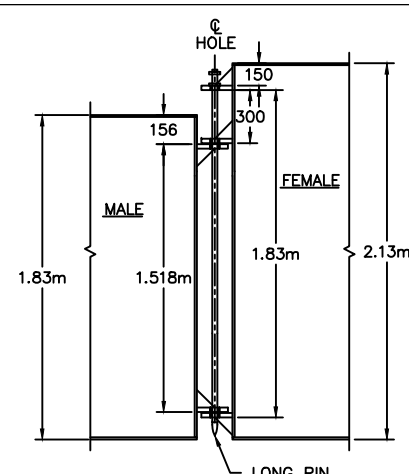

B HIGH/LOW BARGE CONNECTION

SCALE: 1 : 20

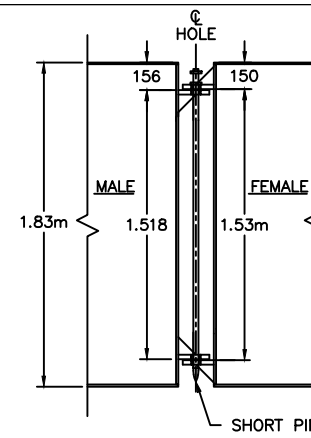

C LOW BARGE CONNECTION
PILE GUIDE CONN. SIMILAR

SCALE: 1 : 20

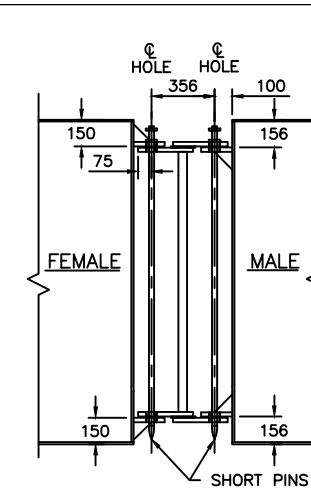

D BARGE CONNECTION - DETAIL

SCALE: 1 : 20

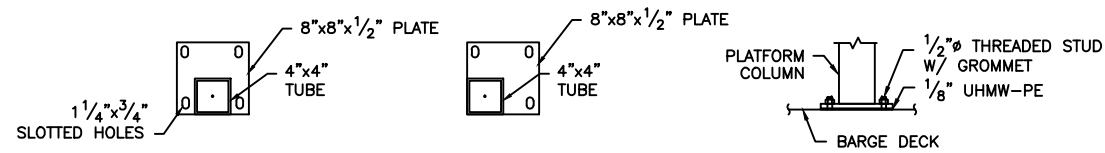

NOTE:
CONNECTION SHALL BE 4-1/2" SS THD' STUDS W/GROMMET,
NUT & WASHER WITH 1/8"x9"x9" UHMW-PE BELOW BASE PLATE

E PLATFORM BASE CONNECTION

SCALE: 1 : 10

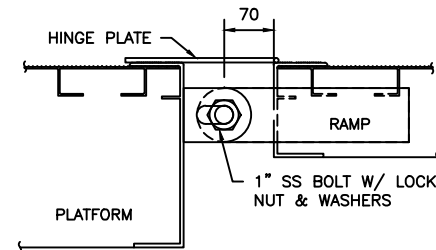

F RAMP TO PLATFORM CONNECTION

SCALE: 1 : 5

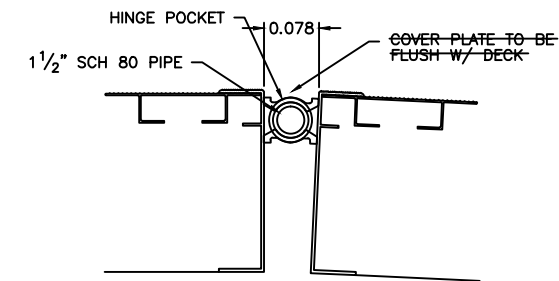

NOTE
SECURE SCH 80 PIPE TO PREVENT LONGITUDINAL MOVEMENT

G STANDARD HINGE POCKET CONNECTION

SCALE: 1 : 5

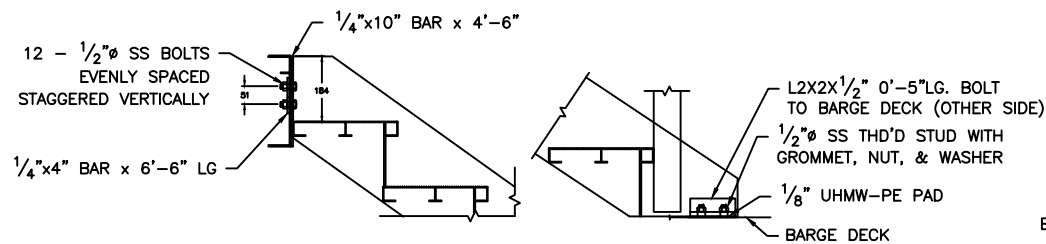

H STAIR CONNECTIONS

SCALE: 1 : 10

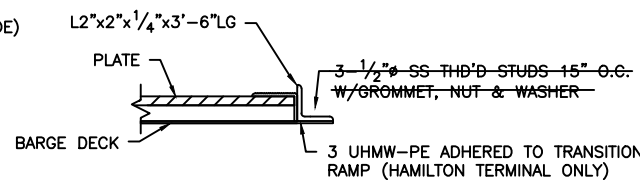

I TRANSITION CONNECTION

SCALE: 1 : 5

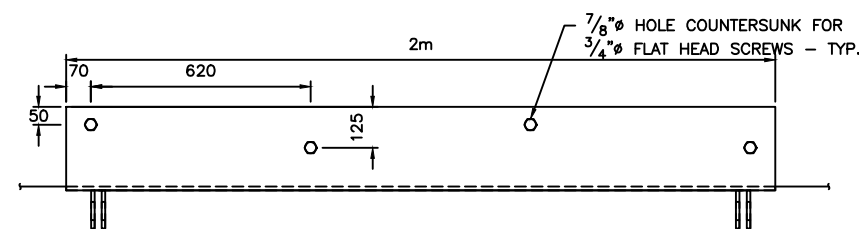

K PLAN

K GANGWAY LANDSIDE CONNECTION - STANDARD DETAIL

SCALE: 1 : 10

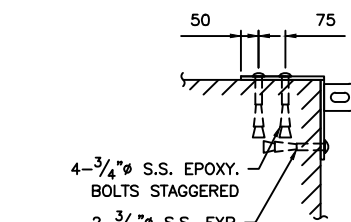

L SECTION

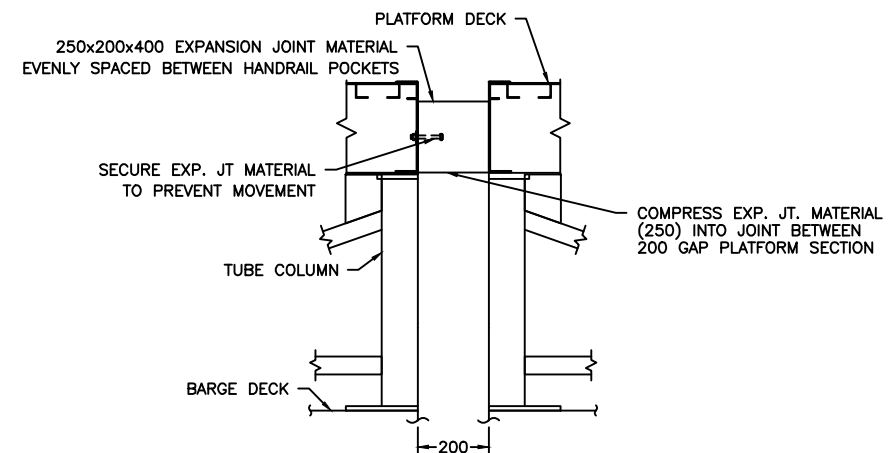

J PLATFORM TO PLATFORM CONNECTION

SCALE: 1 : 10

Reference Drawings

CONSTRUCTION

Structures Section

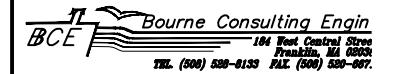

GENERAL NOTES:

ISSUED FOR: CONSTRUCTION 14/08/01

AMENDMENTS:

NO:	REVISION	APP	DATE:
B	HOOP ORIENTATION	RRB	04/01/02
C	BALLAST LAYOUT	RRB	11/01/02

SCALE: 1 : 100

SURVEY
PREPARED BY: DATE: 23/05/01

DESIGN
PREPARED BY: BAP DATE: 23/05/01
CHECKED BY: RRB DATE: 23/05/01

DRAWING
PREPARED BY: JSK DATE: 23/05/01
CHECKED BY: BAP DATE: 23/05/01

APPROVED BY: RRB

PROJECT NUMBER: 61/01/01

PROJECT NAME:
**HAMILTON TERMINAL
REPLACEMENT FERRY PROJEC
PHASE 1
DOCK CONSTRUCTION**

**#1 POINT PLEASANT ROAD
PEMBROKE PARISH**

DRAWING FILE NO: ACAD R-14
HT-6_Ballasting_Plan

SHEET TITLE:
**BALLASTING
PLAN**

SHEET NUMBER: 13/26/02/HT6

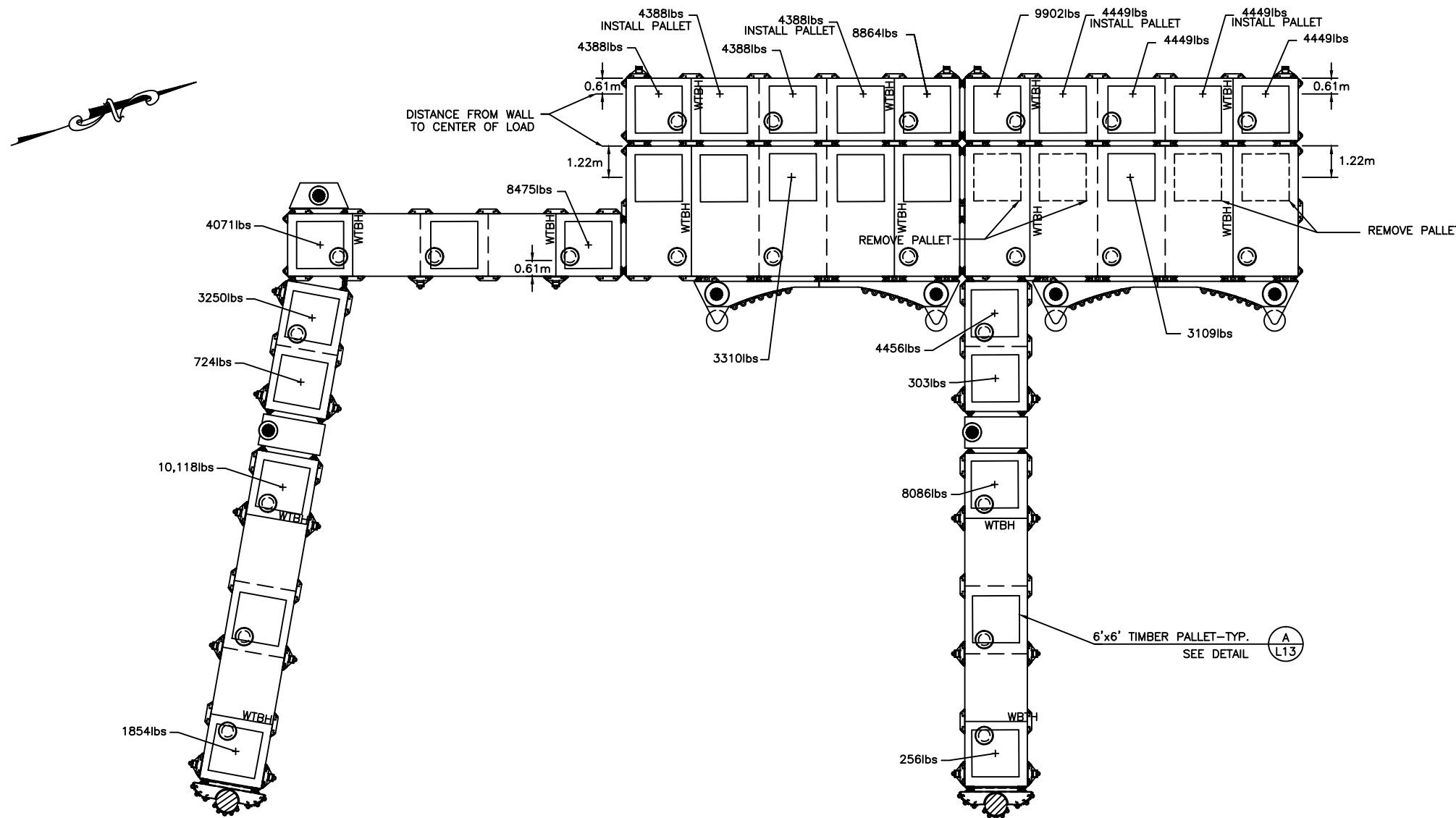

HAMILTON TERMINAL

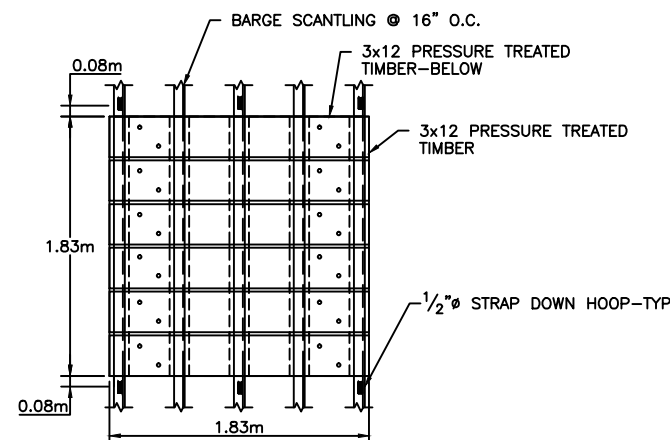

BALLAST PALLET-PLAN

SCALE: 1 : 25

CONSTRUCTION

NOTES:

- BALLAST LOADS ARE SHOWN AT CENTER OF BAY UNLESS NOTED OTHERWISE.
- BALLAST TO BE REMOVABLE CONCRETE BLOCK OR LEAD.
- BALLAST SHALL BE INSTALLED ON TIMBER PALLETS AT LOCATIONS SHOWN. PALLETS SUPPLIED WITH BARGES.

Reference Drawings

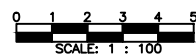

SCALE: 1 : 100

Structures Section

BCE Bourne Consulting Engin
184 West Central Street
Franklin, MA 02045
TEL (508) 528-0133 FAX (508) 528-0077

GENERAL NOTES:

ISSUED FOR: CONSTRUCTION 14/08/01

AMENDMENTS:

NO:	REVISION	APP	DATE:

SCALE: 1 : 50

SURVEY

PREPARED BY: DATE:

DESIGN

PREPARED BY: BAP DATE: 23/05/01

CHECKED BY: RRB DATE: 23/05/01

DRAWING

PREPARED BY: JSK DATE: 23/05/01

CHECKED BY: BAP DATE: 23/05/01

APPROVED BY: RRB

PROJECT NUMBER: 61/01/01

PROJECT NAME:

HAMILTON TERMINAL
REPLACEMENT FERRY PROJEC

PHASE 1
DOCK CONSTRUCTION

#1 POINT PLEASANT ROAD
PEMBROKE PARISH

DRAWING FILE NO: ACAD R-14

HT-8 Wall Notch.dwg

SHEET TITLE:

WALL NOTCH
CONSTRUCTION

SHEET NUMBER: 13/26/02/HT8

REVISION

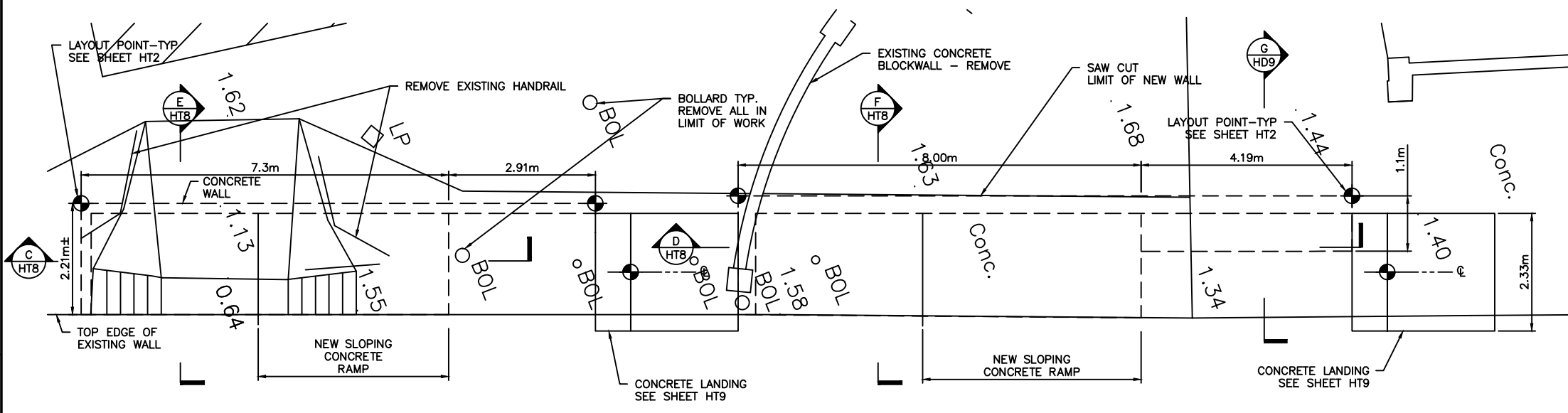

SOUTH NOTCH - PLAN

NORTH NOTCH - PLAN

SCALE: 1 : 50

SCALE: 1 : 50

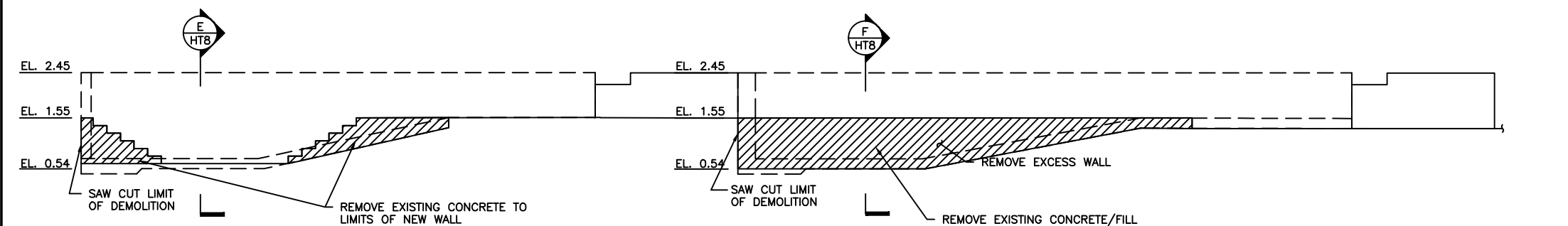

SOUTH NOTCH - ELEVATION

NORTH NOTCH - ELEVATION

SCALE: 1 : 50

SCALE: 1 : 50

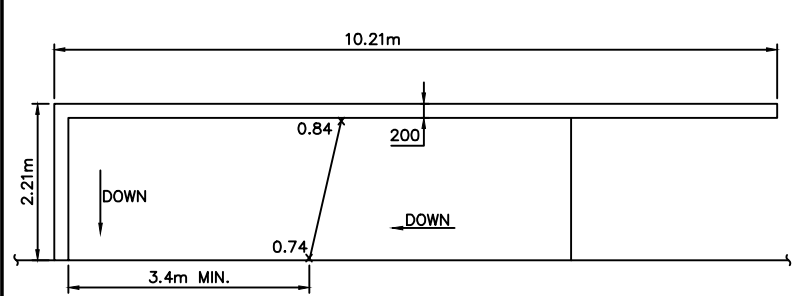

SOUTH NOTCH - PLAN

SCALE: 1 : 50

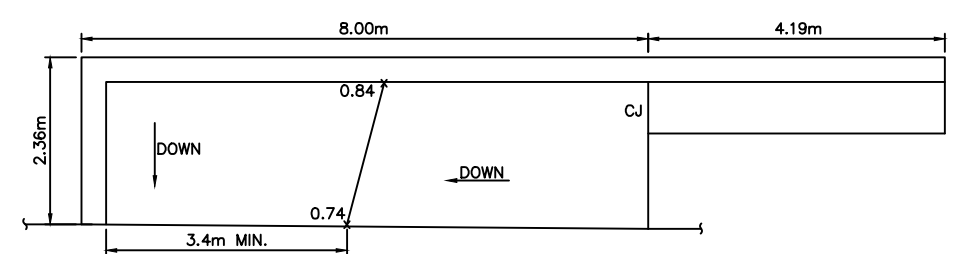

NORTH NOTCH - PLAN

SCALE: 1 : 50

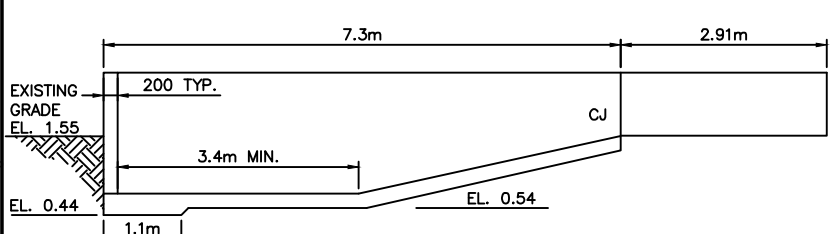

SOUTH NOTCH - ELEVATION

SCALE: 1 : 50

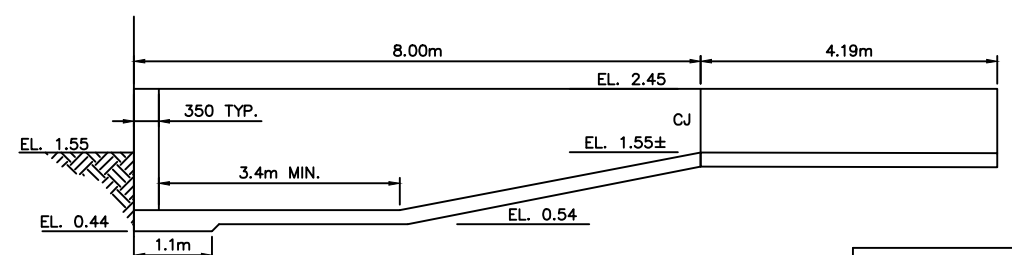

NORTH NOTCH - ELEVATION

SCALE: 1 : 50

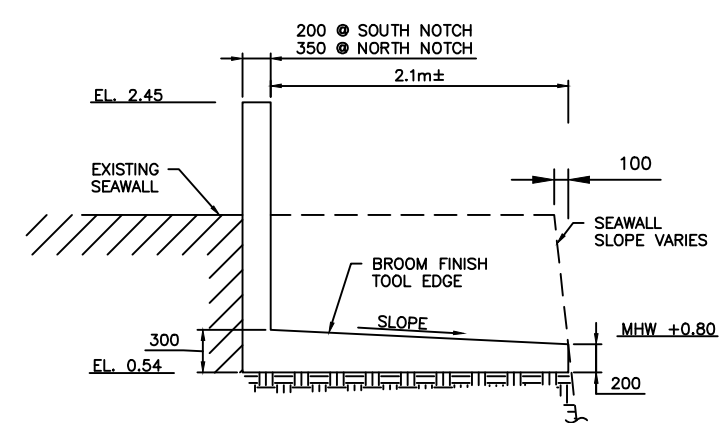

WALL - CROSS SECTION

SCALE: 1 : 25

CONSTRUCTION

- NOTE:
- * ALL REINFORCING STEEL TO BE HOT DIPPED GALVANIZED.
 - * REINFORCING SHALL HAVE A MINIMUM COVER OF 75mm.
 - * 25 CHAMFER ON ALL EDGES UNO.

Reference Drawings

SHEET NUMBER: 13/26/02/HT8

REVISION

Structures Section

GENERAL NOTES:

ISSUED FOR: CONSTRUCTION 14/08/01

AMENDMENTS:

NO:	REVISION	APP	DATE:

SCALE: AS NOTED

SURVEY

PREPARED BY: DATE:

DESIGN

PREPARED BY: BAP DATE: 23/05/01

CHECKED BY: RRB DATE: 23/05/01

DRAWING

PREPARED BY: RFG DATE: 23/05/01

CHECKED BY: RRB DATE: 23/05/01

APPROVED BY: RRB

PROJECT NUMBER: 61/01/01

PROJECT NAME:

HAMILTON TERMINAL
REPLACEMENT FERRY PROJEC
PHASE 1
DOCK CONSTRUCTION

#1 POINT PLEASANT ROAD
PEMBROKE PARISH

DRAWING FILE NO: ACAD R-14

HT-10_Gandway_Pier_Ext.dwg

SHEET TITLE:

GANGWAY PIER
EXTENTION

SHEET NUMBER: 13/26/02/HT10

REVISION

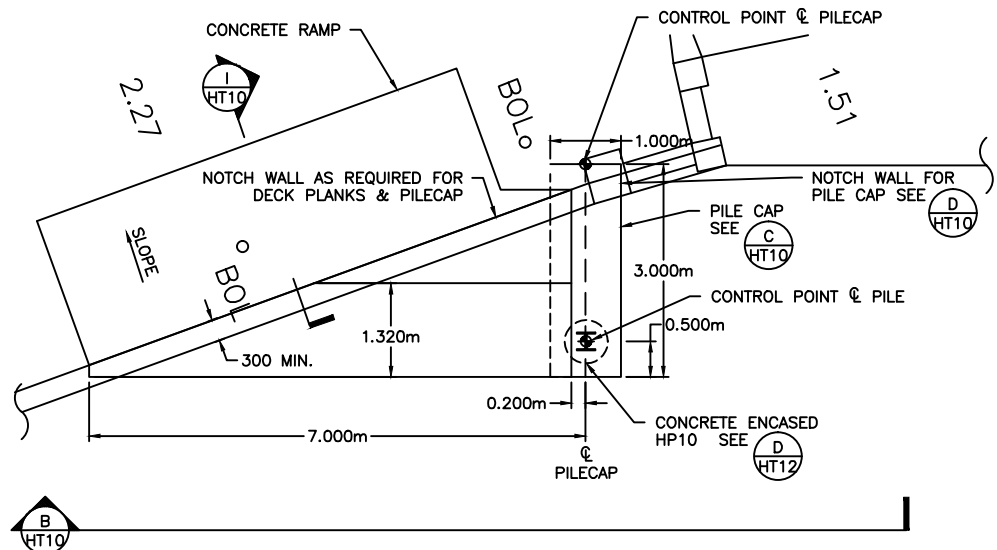

GANGWAY PIER
EXTENTION-PLAN

A
HT10

SCALE: 1 : 50

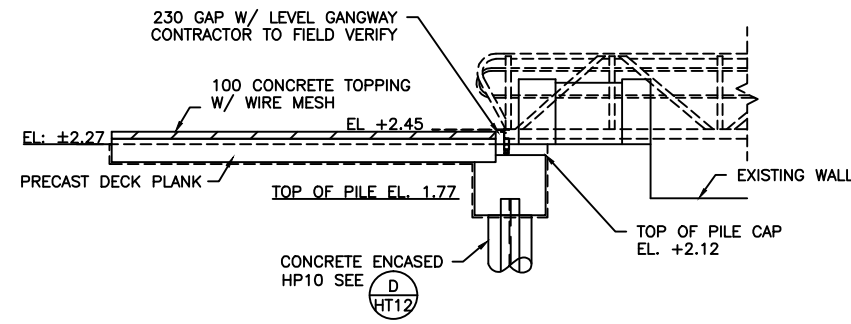

GANGWAY PIER
EXTENTION-ELEVATION

B
HT10

SCALE: 1 : 50

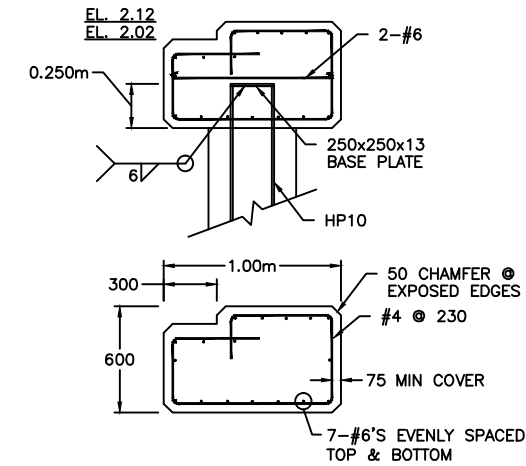

PILE CAP-REINFORCING

C
HT10

SCALE: 1 : 20

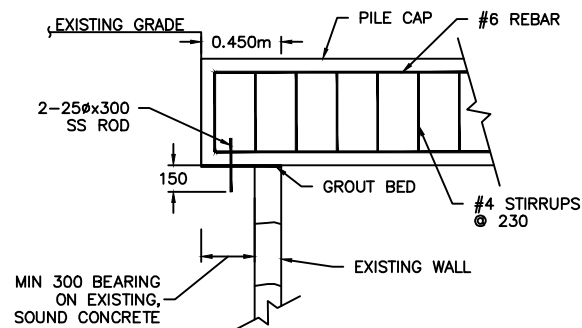

PILE CAP NOTCH

D
HT10

SCALE: 1 : 20

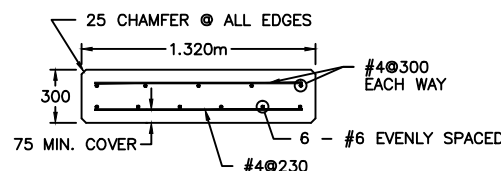

PIER SLAB-REINFORCING

E
HT10

SCALE: 1 : 20

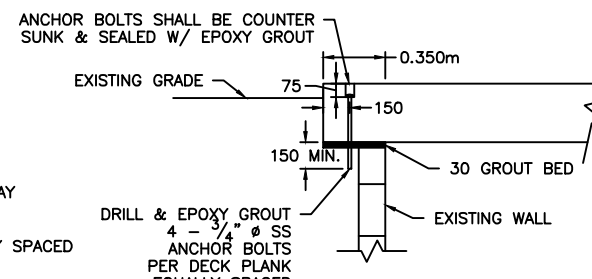

SLAB / WALL CONNECTION

F
HT10

SCALE: 1 : 20

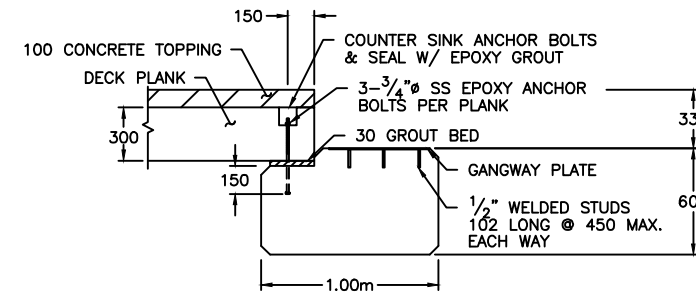

PILE CAP-DETAIL

G
HT10

SCALE: 1 : 20

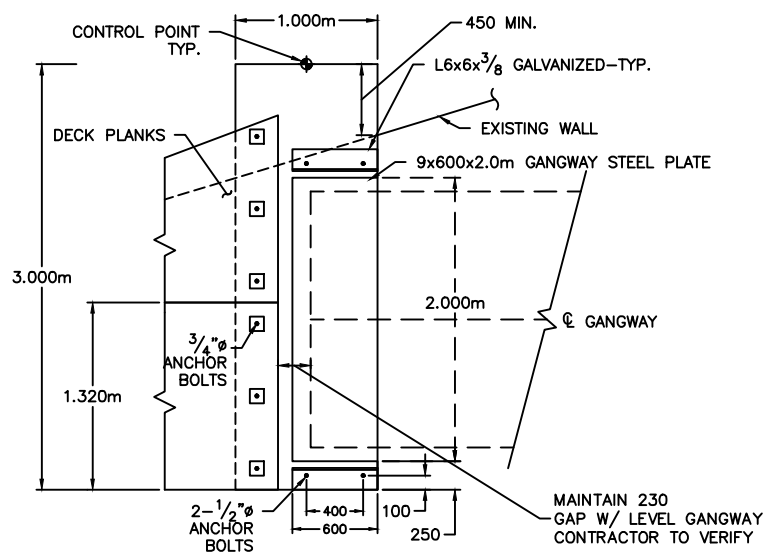

PILE CAP PLAN

H
HT10

SCALE: 1 : 25

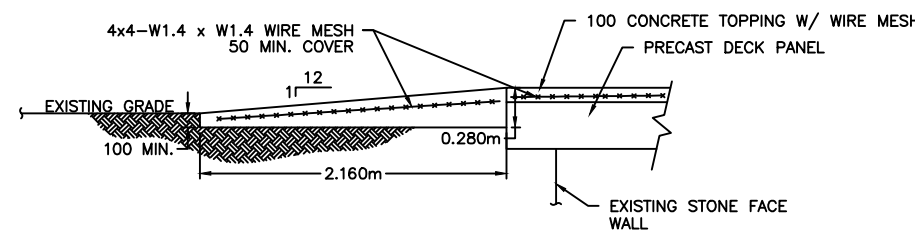

TRANSITION RAMP

I
HT10

SCALE: 1 : 25

Reference Drawings CONSTRUCTION

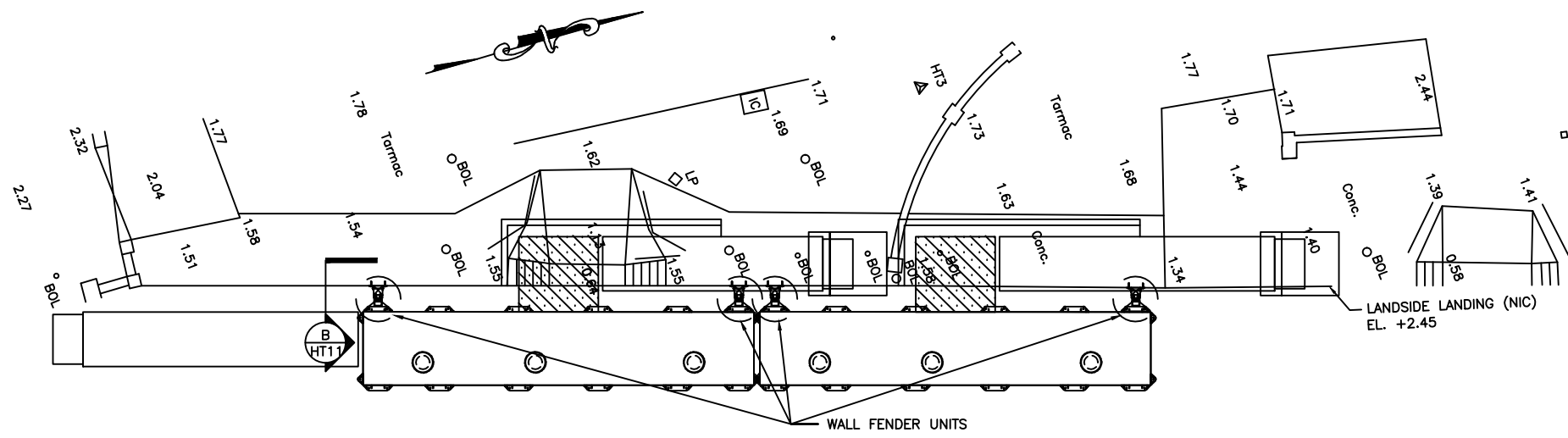

TERMINAL PARTIAL PLAN
 SCALE: 1 : 50

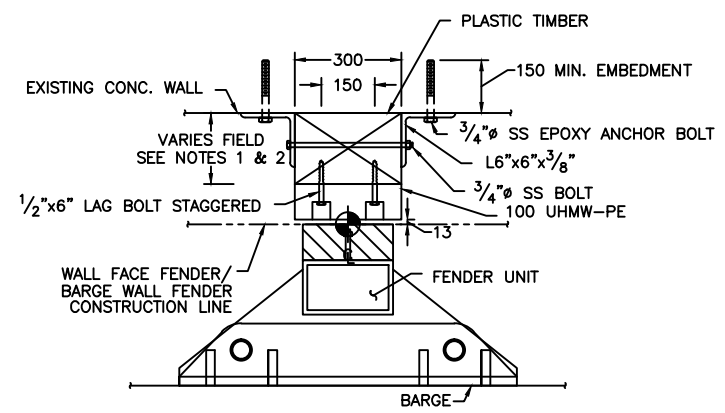

WALL FENDER PLAN
 SCALE: 1 : 10

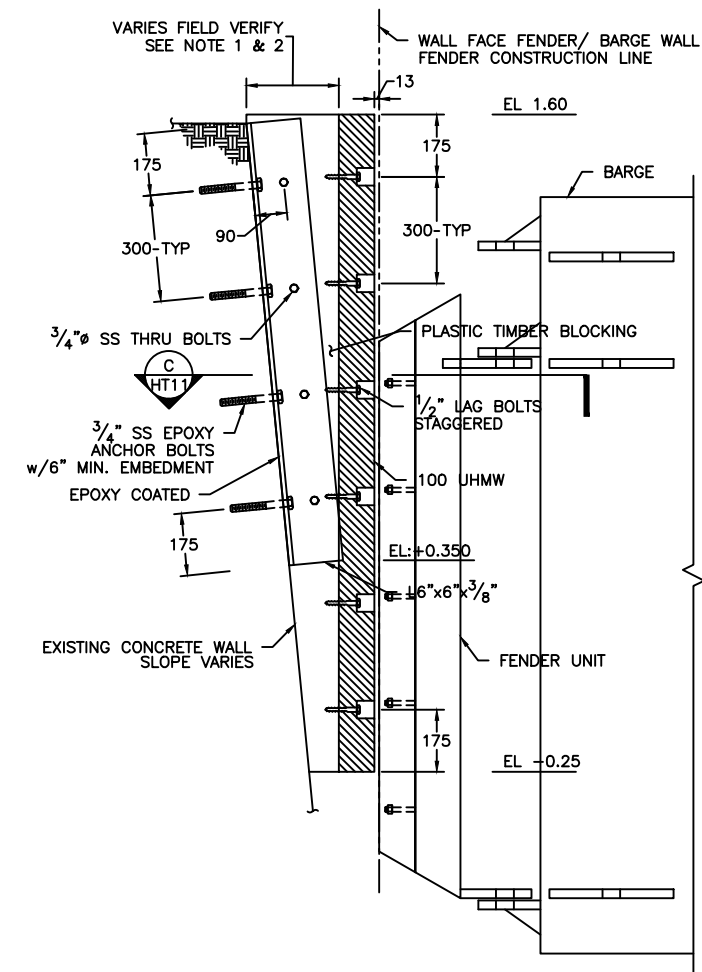

WALL FENDER DETAIL
 SCALE: 1 : 10

- NOTES
1. PLASTIC TIMBER SHALL HAVE MINIMUM THICKNESS OF 100mm @ EL:+0.35.
 2. CONTRACTOR TO FIELD VERIFY SEAWALL SLOPE AND FINAL WALL FACE FENDER/ BARGE WALL FENDER CONSTRUCTION LINE.

THE MINISTRY OF WORKS AND ENGINEERING
 P.O. Box HM525 Hamilton HM CX Bermuda
 Phone: (441)295-5151

ENGINEERING and OPERATIONS DIVISION
 Fax: (441)295-0170

Structures Section
 Bourne Consulting Engin
 BCE 184 West Central Street
 Franklin, MA 02033
 TEL. (508) 528-8133 FAX. (508) 528-8077

GENERAL NOTES:

ISSUED FOR: CONSTRUCTION 14/08/01

AMENDMENTS:

NO:	REVISION	APP	DATE:

SCALE: AS NOTED

SURVEY

PREPARED BY:	DATE:

DESIGN

PREPARED BY:	DATE:
BAP	23/05/01

CHECKED BY:	DATE:
RRB	23/05/01

DRAWING

PREPARED BY:	DATE:
JSK	23/05/01

CHECKED BY:	DATE:
BAP	23/05/01

APPROVED BY:

RRB

PROJECT NUMBER:
61/01/01

PROJECT NAME:
HAMILTON TERMINAL REPLACEMENT FERRY PROJECT PHASE 1 DOCK CONSTRUCTION

#1 POINT PLEASANT ROAD PEMBROKE PARISH

DRAWING FILE NO: ACAD R-14
HT-11_Wall-Fender.dwg

SHEET TITLE:
WALL FENDER

SHEET NUMBER:
13/26/02/HT11

REVISION
^

Reference CONSTRUCTION Drawings

Structures Section

GENERAL NOTES:

ISSUED FOR: CONSTRUCTION 14/08/01

AMENDMENTS:

NO:	REVISION	APP	DATE:
A	WEAR SURFACE	RRB	04/01/02

SCALE: AS NOTED

SURVEY

PREPARED BY: DATE:

DESIGN

PREPARED BY: BAP DATE: 23/05/01

CHECKED BY: RRB DATE: 23/05/01

DRAWING

PREPARED BY: BAP DATE: 23/05/01

CHECKED BY: RRB DATE: 23/05/01

APPROVED BY: RRB

PROJECT NUMBER:
61/01/01

PROJECT NAME:

HAMILTON TERMINAL
REPLACEMENT FERRY PROJECT
PHASE 1
DOCK CONSTRUCTION

#1 POINT PLEASANT ROAD
PEMBROKE PARISH

DRAWING FILE NO: ACAD R-14
HT-12 Mooring Piles.dwg

SHEET TITLE:

MOORING PILES

SHEET NUMBER:
13/26/02/HT12

REVISION

A

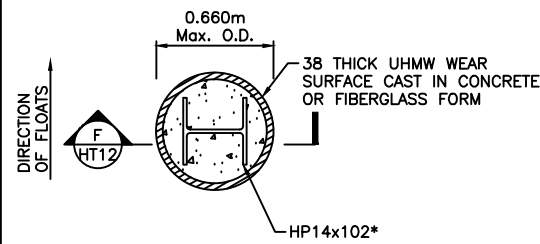

* NOTE: PILE SHALL BE ORIENTED PERPENDICULAR TO FLOATS

A HT12
TYPE I MOORING PILE
SCALE: 1 : 20

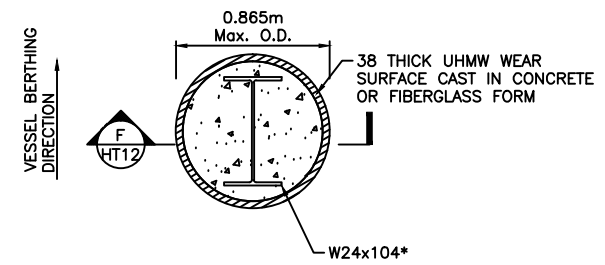

* NOTE: PILE SHALL BE ORIENTED IN VESSEL BERTHING DIRECTION

B HT12
TYPE II MOORING PILE
SCALE: 1 : 20

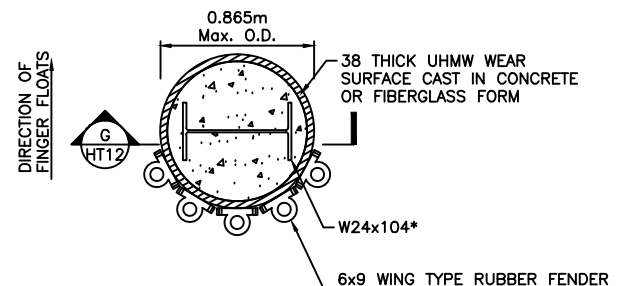

* NOTE: PILE SHALL BE ORIENTED PERPENDICULAR TO FINGER FLOATS

C HT12
TYPE III MOORING PILE
SCALE: 1 : 20

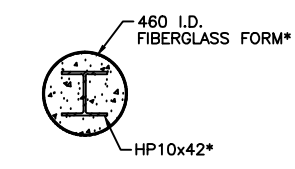

* ONE OR TWO PIECE REMOVABLE FORMS ALLOWED

D HT12
STANDARD BEARING PILE
SCALE: 1 : 20

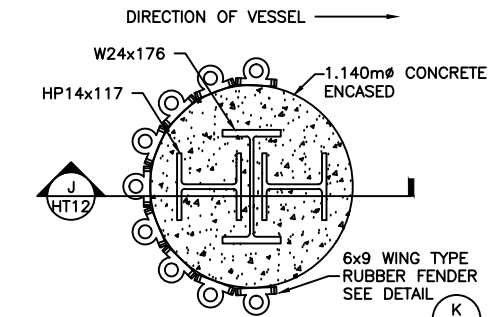

E HT12
SIDE DOLPHIN PLAN @ ELEV. 0.0M
SCALE: 1 : 20

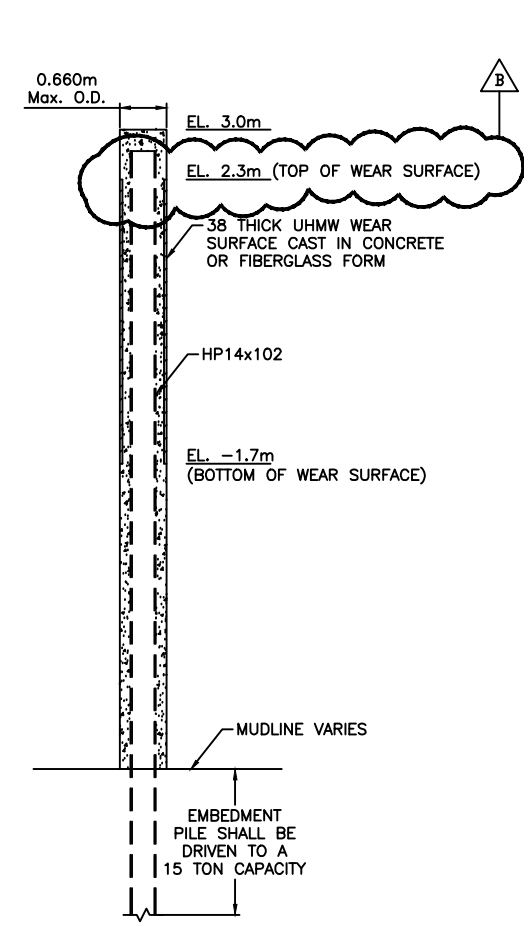

F HT12
TYPE I MOORING PILE - SECTION
SCALE: 1 : 50

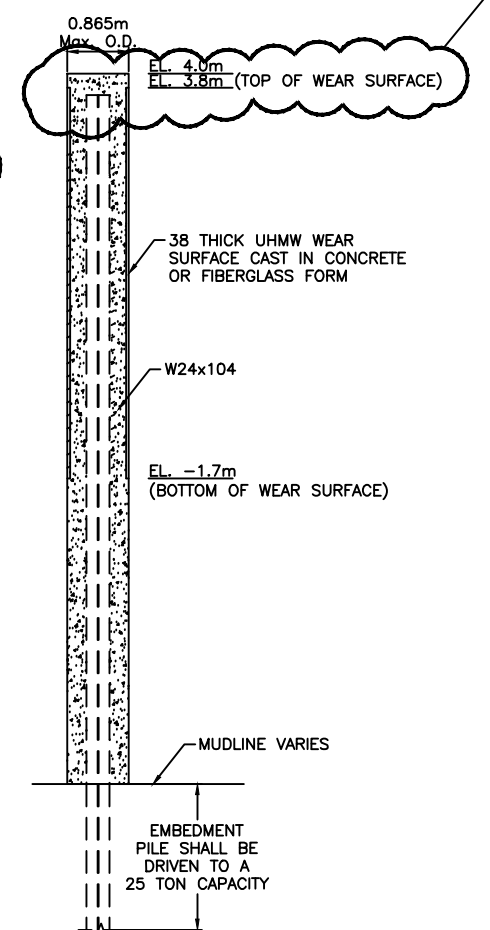

G HT12
TYPE II MOORING PILE - SECTION
SCALE: 1 : 50

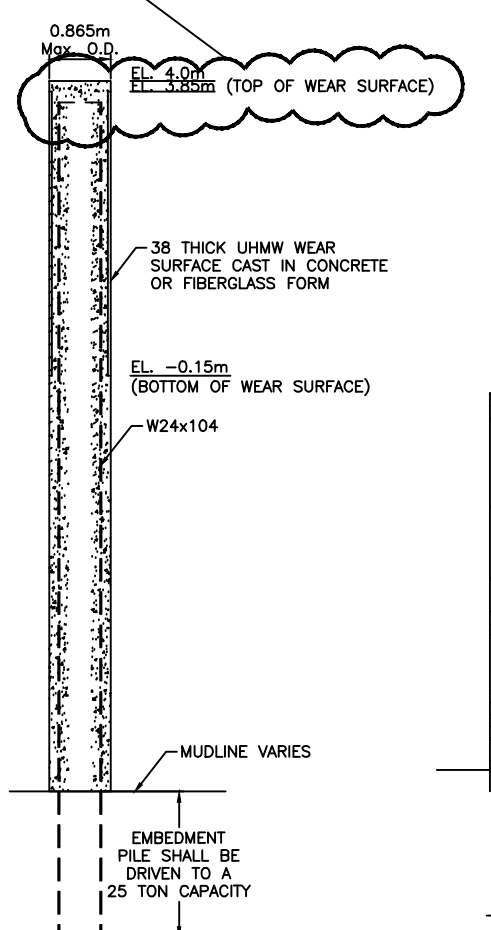

H HT12
TYPE III MOORING PILE - SECTION
SCALE: 1 : 50

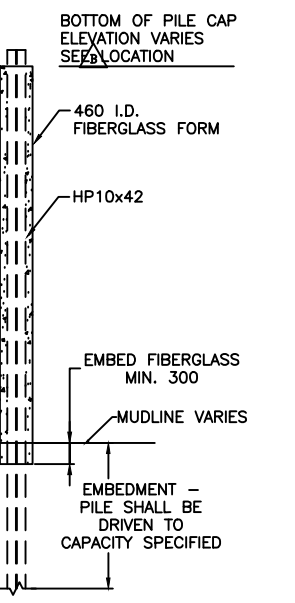

I HT12
STANDARD BEARING PILE - SECTION
SCALE: 1 : 50

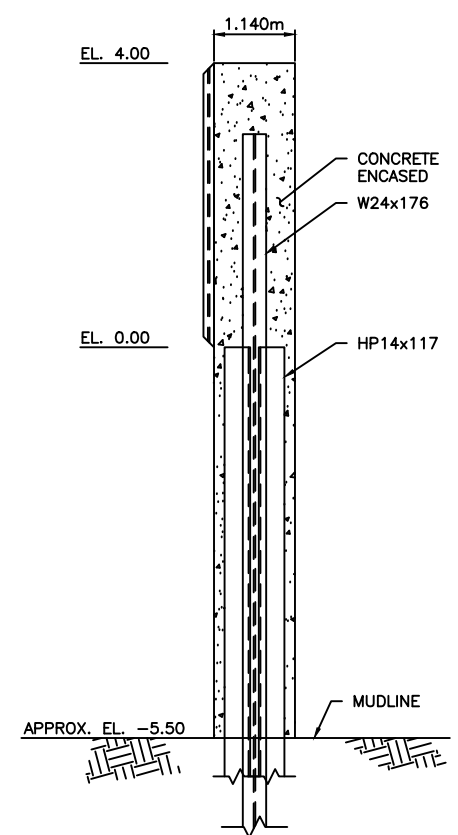

J HT12
SIDE DOLPHIN - SECTION
SCALE: 1 : 50

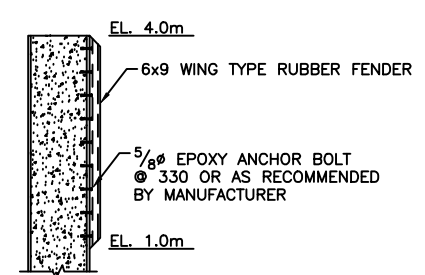

K HT12
RUBBER UNIT - CONNECTION
SCALE: 1 : 50

NOTE:
FIBERGLASS FORMS MAYBE 1 OR 2 PIECE REMOVABLE FORMS

PILE TYPE	ASSUMED TIP ELEV. FOR TENDER
MOORING PILE TYPE I	-37.5
MOORING PILE TYPE II	-37.5
MOORING PILE TYPE III	-37.5
STD. BEARING PILE	-37.5
DOLPHIN	-37.5

CONSTRUCTION Reference Drawings

GENERAL NOTES:

ISSUED FOR: CONSTRUCTION 14/08/01

AMENDMENTS:

NO:	REVISION	APP	DATE:
Δ	TYPE I PLATE	RRB	04/01/02

SCALE: AS NOTED

SURVEY
PREPARED BY: DATE:

DESIGN
PREPARED BY: BAP DATE: 23/05/01
CHECKED BY: RRB DATE: 23/05/01

DRAWING
PREPARED BY: JSK DATE: 23/05/01
CHECKED BY: BAP DATE: 23/05/01

APPROVED BY: RRB

PROJECT NUMBER:
61/01/01

PROJECT NAME:
HAMILTON TERMINAL
REPLACEMENT FERRY PROJEC
PHASE 1
DOCK CONSTRUCTION

#1 POINT PLEASANT ROAD
PEMBROKE PARISH

DRAWING FILE NO: ACAD R-14
HT-13 Misc. Details.dwg

SHEET TITLE:
MISC.
DETAILS

SHEET NUMBER: 13/26/02/HT13 REVISION: Δ

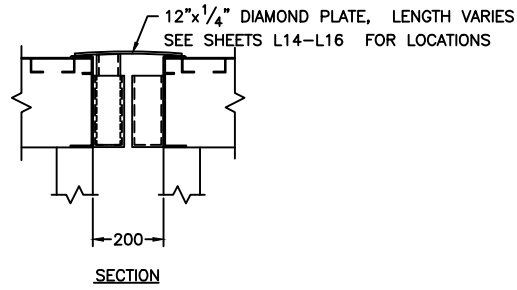

PLATFORM TO PLATFORM TRANSITION PLATE

SCALE: 1 : 10

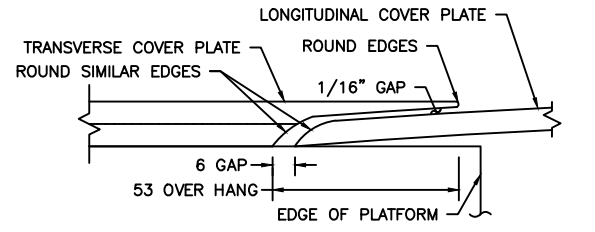

COVER PLATE CROSSING-SECTION

SCALE: 1 : 1

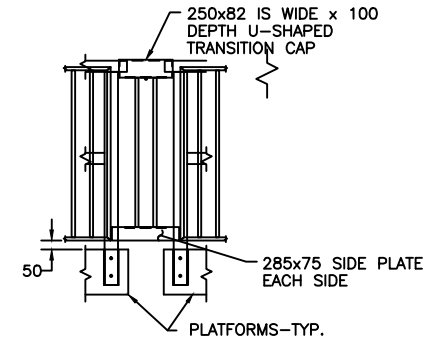

HANDRAIL CONNECTION

SCALE: 1 : 20

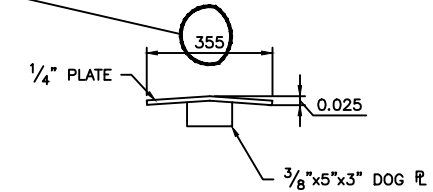

SECTION

SCALE: 1 : 10

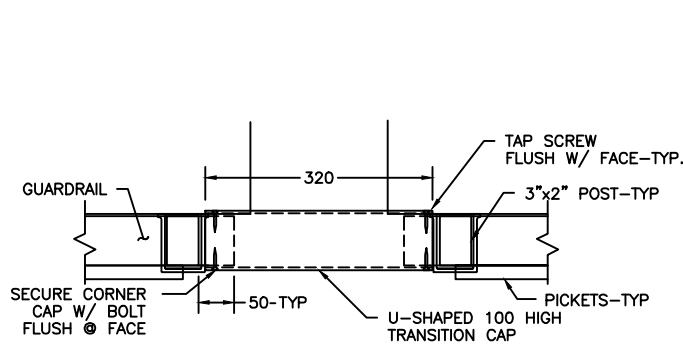

GUARDRAIL TRANSITION

SCALE: 1 : 5

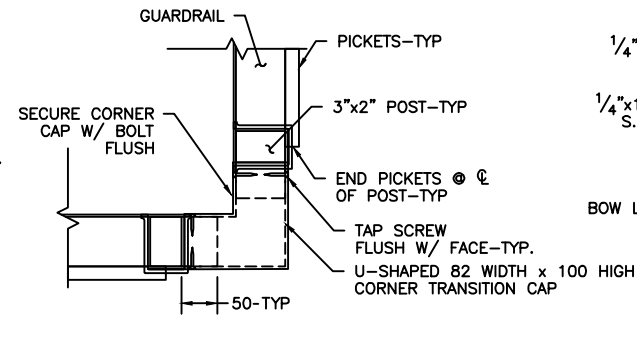

BOW LOADER COVER PLATE

SCALE: 1 : 10

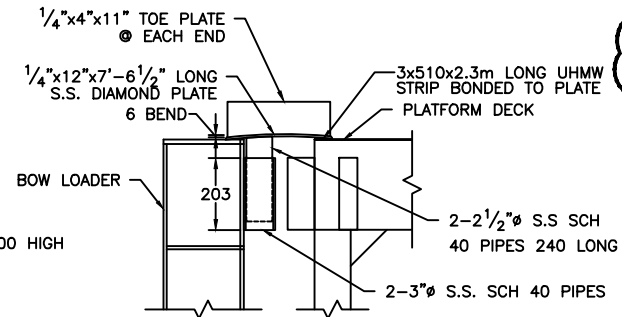

STEEL BARGE COVER PLATES

SCALE: 1 : 20

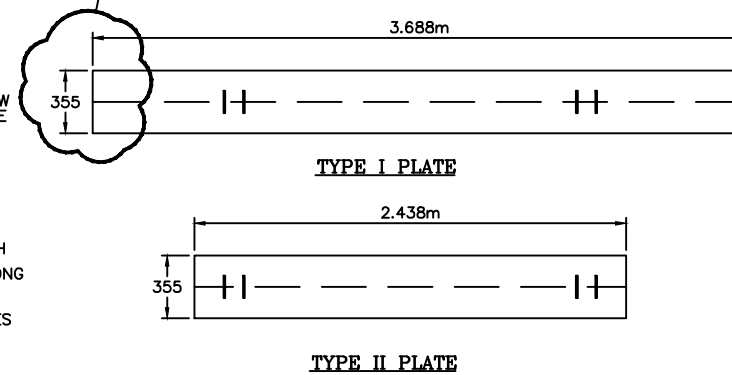

STEEL BARGE COVER PLATES

SCALE: 1 : 20

Reference CONSTRUCTION Drawings

Structures Section



GENERAL NOTES:

1. COORDINATES BASED ON BNG 2000.
2. ALL ELEVATIONS ARE IN METERS BASED ON ORDNANCE DATUM.
3. ALL DISTANCES ARE IN METERS.
4. SURVEY CONTROL SHALL BE PROVIDED TO THE CONTRACTOR BY THE OWNER.

ISSUED FOR: CONSTRUCTION 14/08/01

AMENDMENTS:

NO:	REVISION	APP	DATE:

SCALE: 1 : 200

SURVEY

PREPARED BY: DATE:

DESIGN

PREPARED BY: BAP DATE: 23/05/01

CHECKED BY: RRB DATE: 23/05/01

DRAWING

PREPARED BY: JSK DATE: 23/05/01

CHECKED BY: BAP DATE: 23/05/01

APPROVED BY:

RRB

PROJECT NUMBER:

61/01/01

PROJECT NAME:

DOCKYARD
REPLACEMENT FERRY PROJECT
PHASE 1
DOCK CONSTRUCTION

DOCKYARD TERRACE
SANDYS PARISH

DRAWING FILE NO: ACAD R-14
DY-01_Exist Cond.dwg

SHEET TITLE:

EXISTING
CONDITIONS

SHEET NUMBER: REVISION

61/45/01/DY1

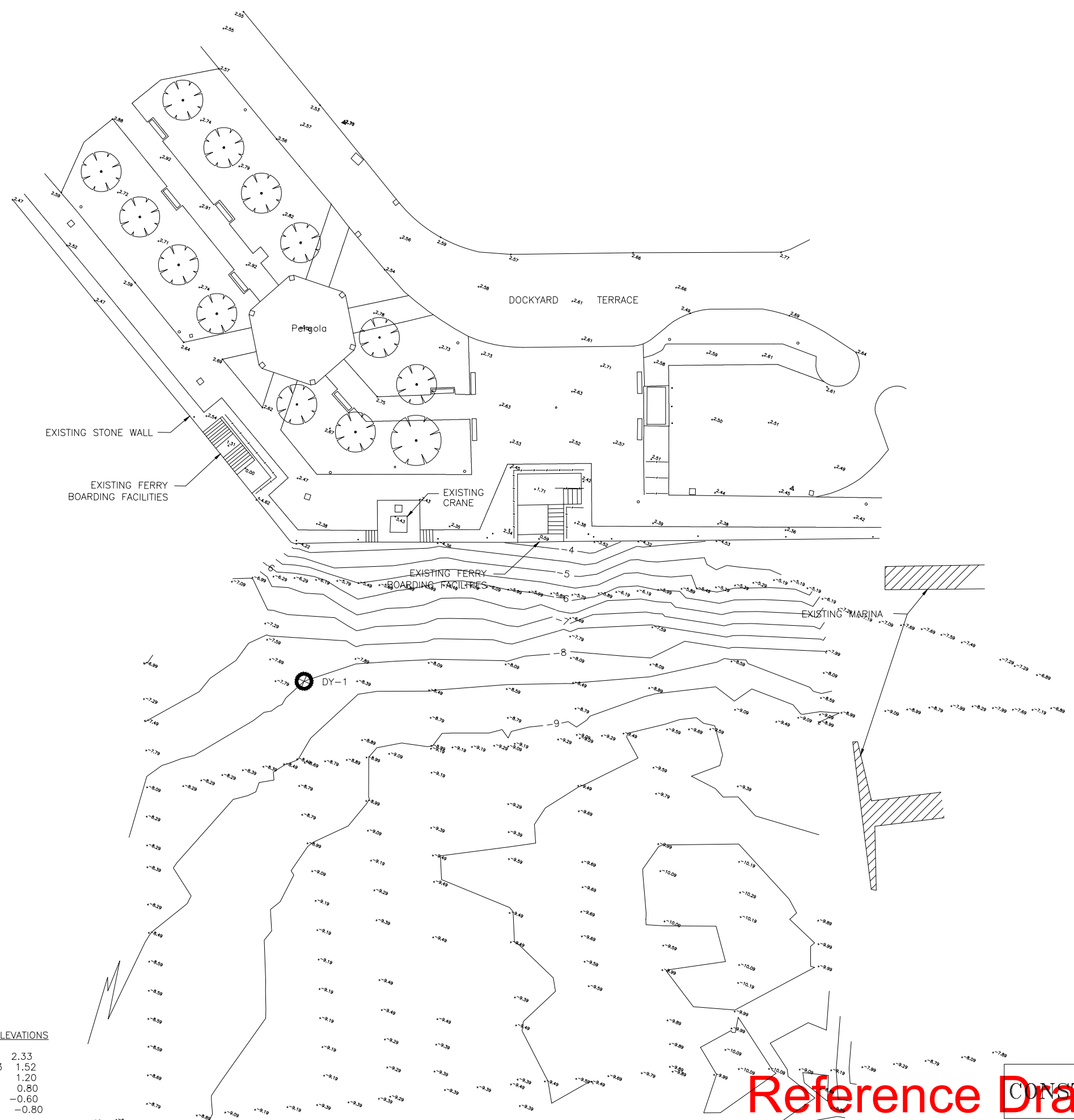

TEST PILE DRIVING LOGS

DEPTH	HAMMER BLOWS/FT
0 FT	0 START
50	0
55	0
60	0
65	4
70	3
75	8
80	8
85	16
90	11
95	21
100	21
105	25
110	42 END

PILE: HP12x87
HAMMER: DELMAG D8-22
ENERGY: 18,000/9,500 FT-lbs/BLOW

NOTES

DY-1 TEST PILE LOCATION.
ALL PILES EXTRACTED.
PERFORMED DECEMBER 2000.

DESIGN WATER ELEVATIONS

HURR.	CAT.	ELEVATION
	5	2.33
	3	1.52
	EHW	1.20
	MHW	0.80
	MLW	-0.60
	ELW	-0.80

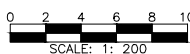

GENERAL NOTES:

ISSUED FOR: CONSTRUCTION 14/08/01

AMENDMENTS:

NO:	REVISION	APP	DATE:
Δ	COVER PLATE	RRB	04/01/02

SCALE: AS NOTED

SURVEY

PREPARED BY: DATE:

DESIGN

PREPARED BY: BAP DATE: 23/05/01

CHECKED BY: RRB DATE: 23/05/01

DRAWING

PREPARED BY: JSK DATE: 23/05/01

CHECKED BY: BAP DATE: 23/05/01

APPROVED BY: RRB

PROJECT NUMBER: 61/01/01

PROJECT NAME:

DOCKYARD

REPLACEMENT FERRY PROJEC

PHASE 1

DOCK CONSTRUCTION

DOCKYARD TERRACE

SANDYS PARISH

DRAWING FILE NO: ACAD R-14

DY-4 Assembly-Connections.dwg

SHEET TITLE:

ASSEMBLY

CONNECTIONS

SHEET NUMBER:

61/45/01/DY4

REVISION

Δ

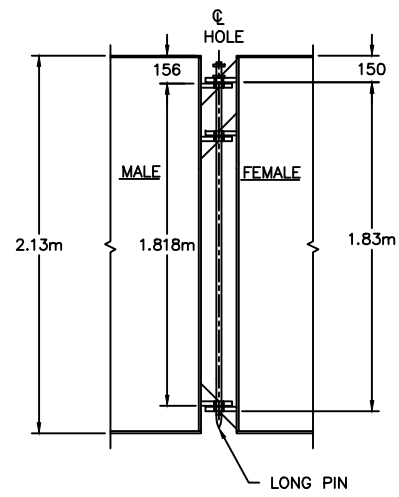

A
DY4
HIGH BARGE CONNECTION
SCALE: 1 : 20

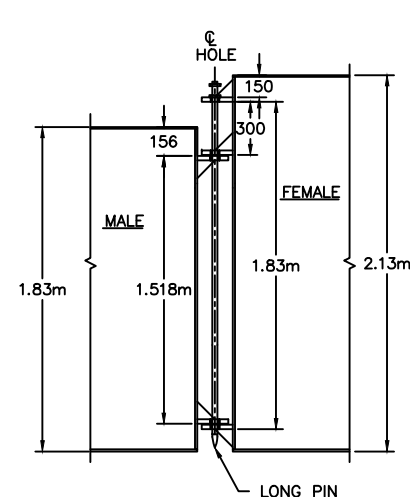

B
DY4
HIGH/LOW BARGE CONNECTION
SCALE: 1 : 20

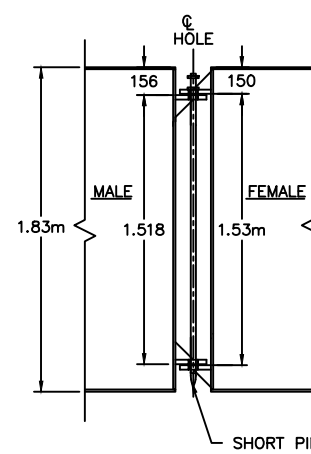

C
DY4
LOW BARGE CONNECTION
PILE GUIDE CONN. SIMILAR
SCALE: 1 : 20

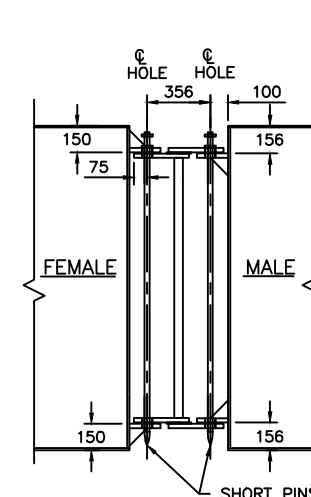

D
DY4
BARGE CONNECTION - DETAIL
SCALE: 1 : 20

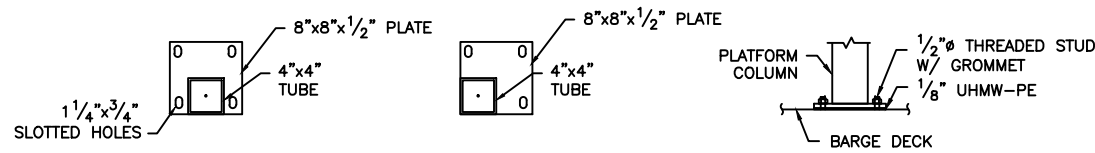

NOTE:
CONNECTION SHALL BE 4-1/2" SS THD' STUDS W/GROMMET,
NUT & WASHER WITH 1/8" x 9" x 9" UHMW-PE BELOW BASE PLATE

E
DY4
PLATFORM BASE CONNECTION
SCALE: 1 : 10

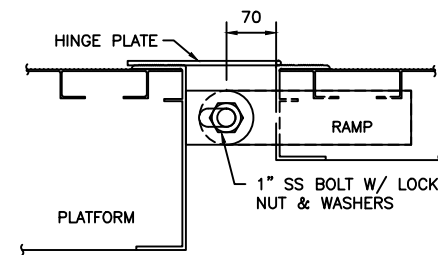

F
DY4
RAMP TO PLATFORM CONNECTION
SCALE: 1 : 5

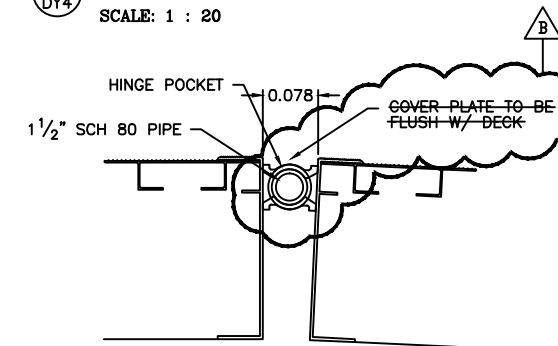

NOTE
SECURE SCH 80 PIPE TO PREVENT LONGITUDINAL MOVEMENT

G
DY4
STANDARD HINGE POCKET CONNECTION
SCALE: 1 : 5

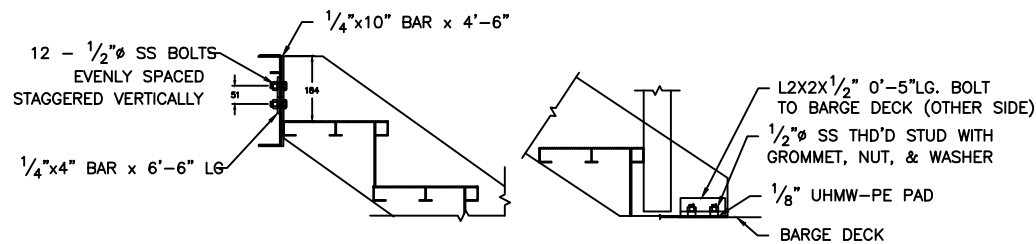

H
DY4
STAIR CONNECTIONS
SCALE: 1 : 10

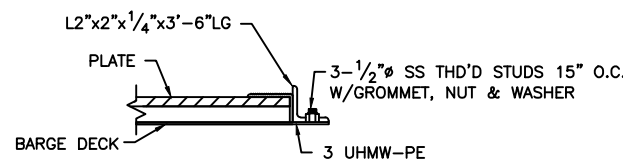

I
DY4
TRANSITION CONNECTION
SCALE: 1 : 5

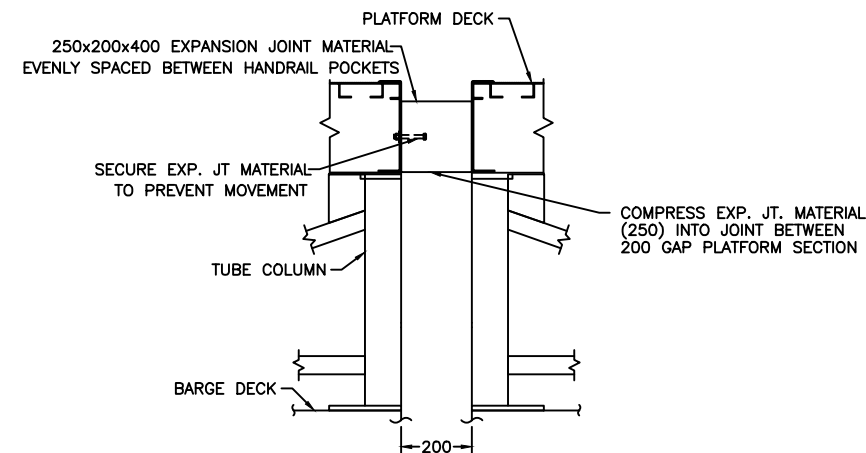

J
DY4
PLATFORM TO PLATFORM CONNECTION
SCALE: 1 : 10

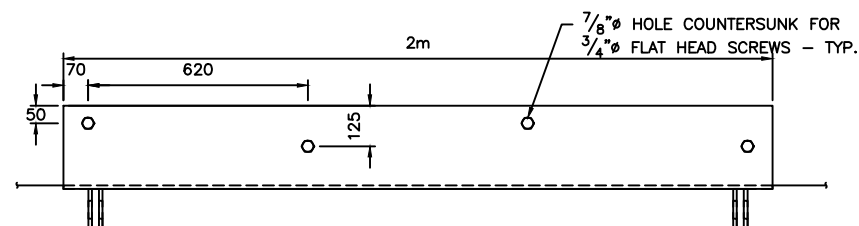

PLAN

K
DY4
GANGWAY LANDSIDE CONNECTION - STANDARD DETAIL
SCALE: 1 : 10

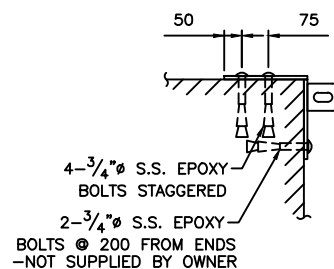

SECTION

CONSTRUCTION

Reference Drawings

Structures Section

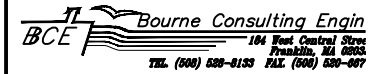

GENERAL NOTES:

NOTES:

1. BALLAST LOADS ARE SHOWN AT CENTER OF BAY UNLESS NOTED OTHERWISE.
2. BALLAST TO BE REMOVABLE CONCRETE BLOCK OR LEAD.
3. BALLAST SHALL BE INSTALLED ON TIMBER PALLETS AT LOCATIONS SHOWN. PALLET SUPPLIED W/ BARGES

ISSUED FOR: CONSTRUCTION 14/08/01

AMENDMENTS:

NO:	REVISION	APP	DATE:
1	HOOP ORIENTATION	RRB	04/01/02
2	BALLAST LAYOUT	RRB	11/02/02

SCALE: AS NOTED

SURVEY

PREPARED BY: DATE:

DESIGN

PREPARED BY: BAP DATE: 23/05/01

CHECKED BY: RRB DATE: 23/05/01

DRAWING

PREPARED BY: JSK DATE: 23/05/01

CHECKED BY: BAP DATE: 23/05/01

APPROVED BY: RRB

PROJECT NUMBER: 61/01/01

PROJECT NAME:
**DOCKYARD
REPLACEMENT FERRY PROJE
PHASE 1
DOCK CONSTRUCTION**

**DOCKYARD TERRACE
SANDYS PARISH**

DRAWING FILE NO: ACAD R-14
DY-05_Ballasting Plan.dwg

SHEET TITLE:

**BALLASTING
PLAN**

SHEET NUMBER: 61/45/01/DY5 REVISION:

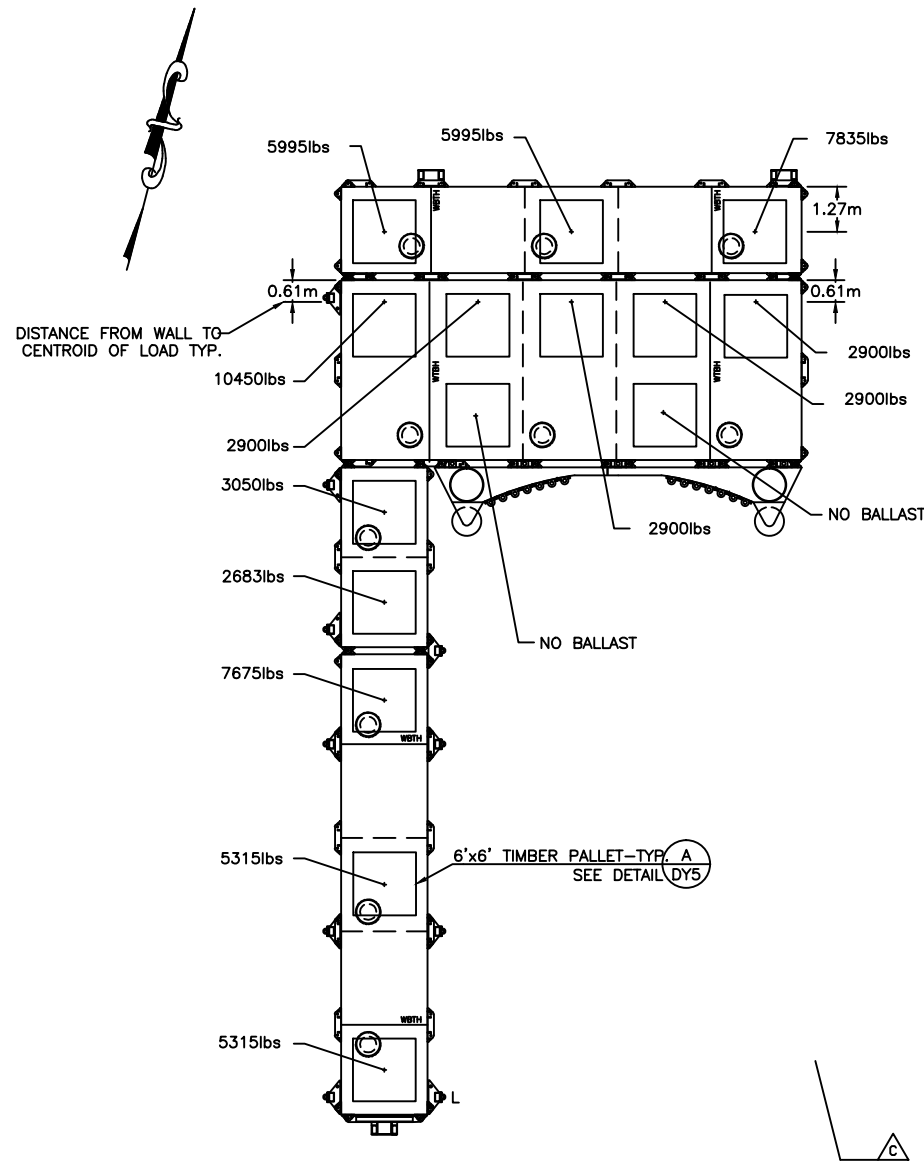

DOCKYARD

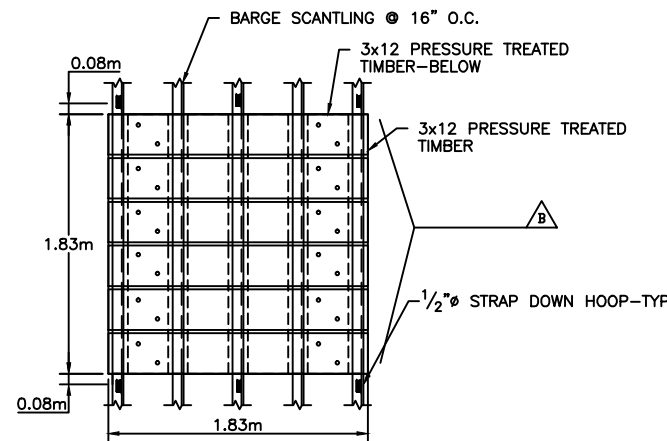

BALLAST PALLET-PLAN
SCALE: 1 : 25

Structures Section

GENERAL NOTES:

ISSUED FOR: CONSTRUCTION 14/08/01

AMENDMENTS:

NO:	REVISION	APP	DATE:

SCALE: AS NOTED

SURVEY

PREPARED BY: DATE:

DESIGN

PREPARED BY: BAP DATE: 23/05/01

CHECKED BY: RRB DATE: 23/05/01

DRAWING

PREPARED BY: BAP DATE: 23/05/01

CHECKED BY: RRB DATE: 23/05/01

APPROVED BY: RRB

PROJECT NUMBER: 61/01/01

PROJECT NAME:

DOCKYARD REPLACEMENT FERRY PROJEC

PHASE 1 DOCK CONSTRUCTION

DOCKYARD TERRACE SANDYS

DRAWING FILE NO: ACAD R-14

DY-6 Gangway Notch.dwg

SHEET TITLE:

GANGWAY NOTCH

PLAN & DETAILS

SHEET NUMBER: 61/45/01/DY6

REVISION

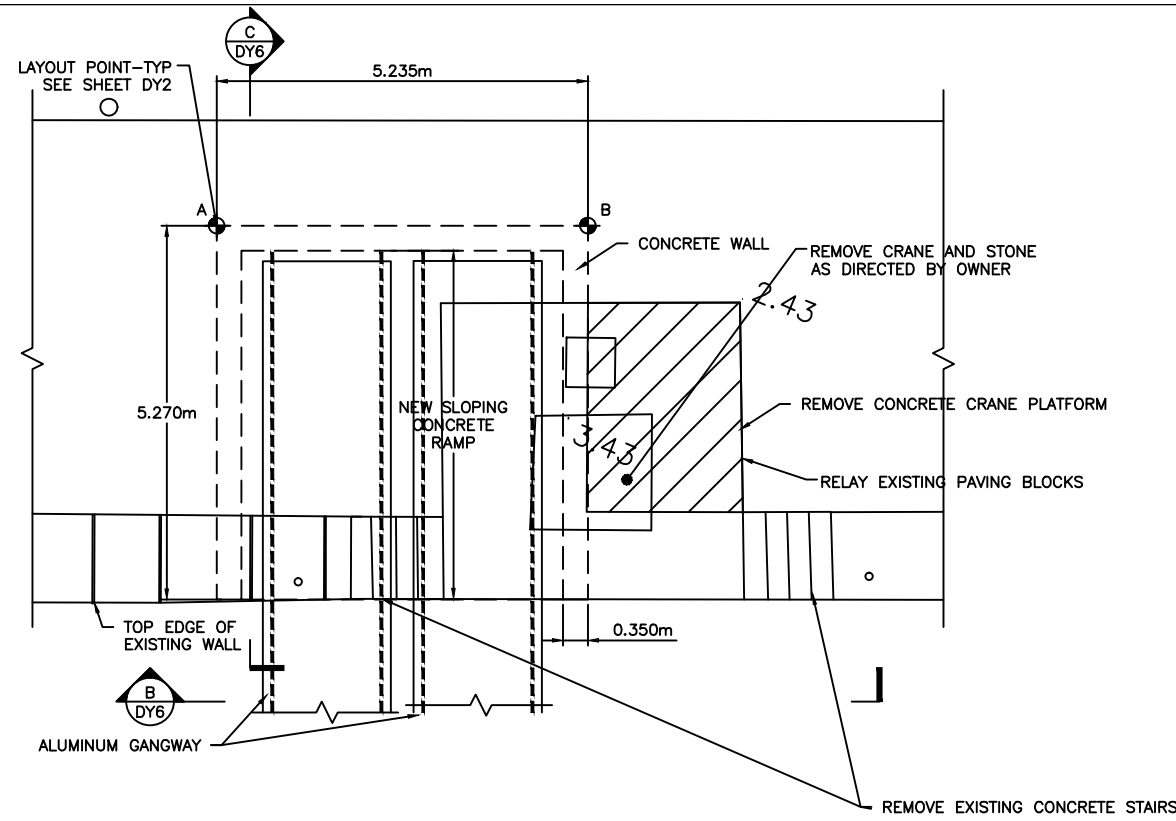

CONCRETE NOTCH-PLAN
SCALE: 1 : 50

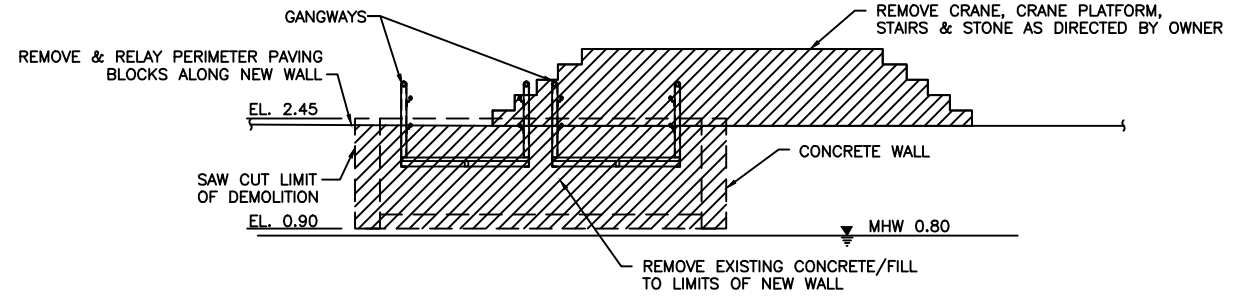

CONCRETE NOTCH-ELEVATION
SCALE: 1 : 50

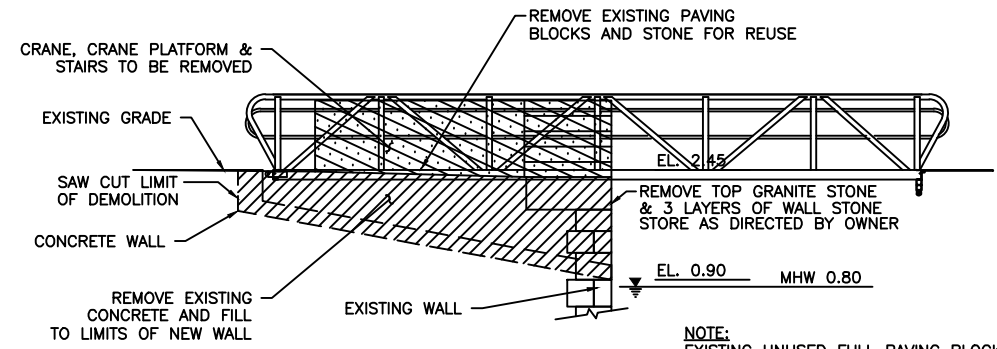

CONCRETE NOTCH-SECTION
SCALE: 1 : 50

NOTE:
NO CHAMFER @ GANGWAY LOCATIONS

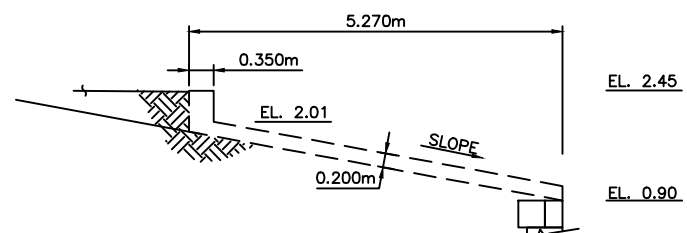

CONCRETE WALL-ELEVATION
SCALE: 1 : 50

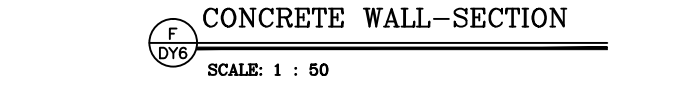

CONCRETE WALL-SECTION
SCALE: 1 : 50

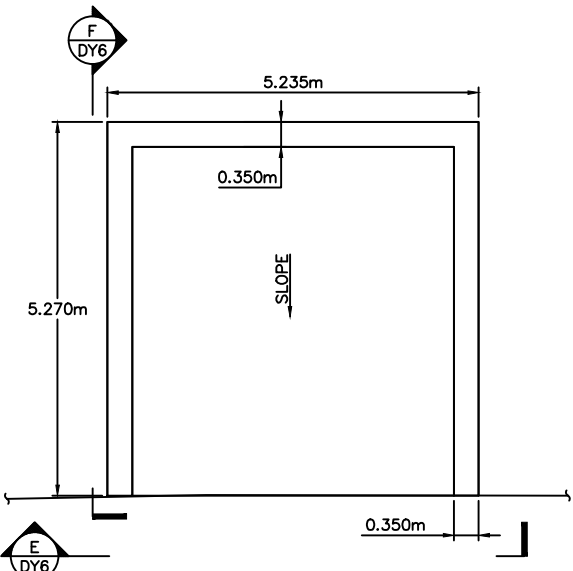

CONCRETE WALL-PLAN
SCALE: 1 : 50

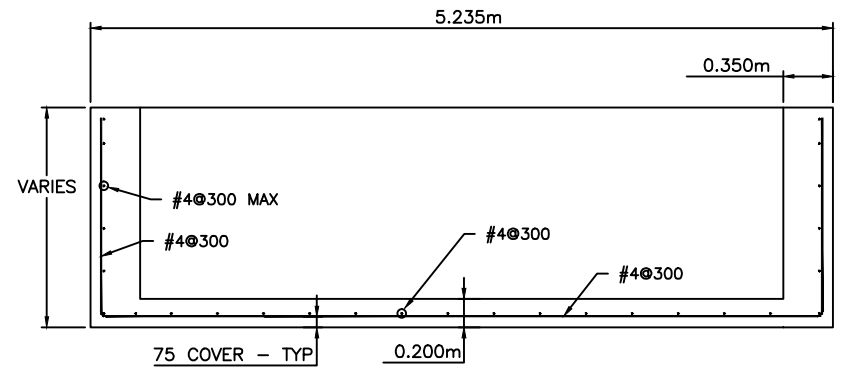

CONCRETE WALL-REINFORCING
SCALE: 1 : 25

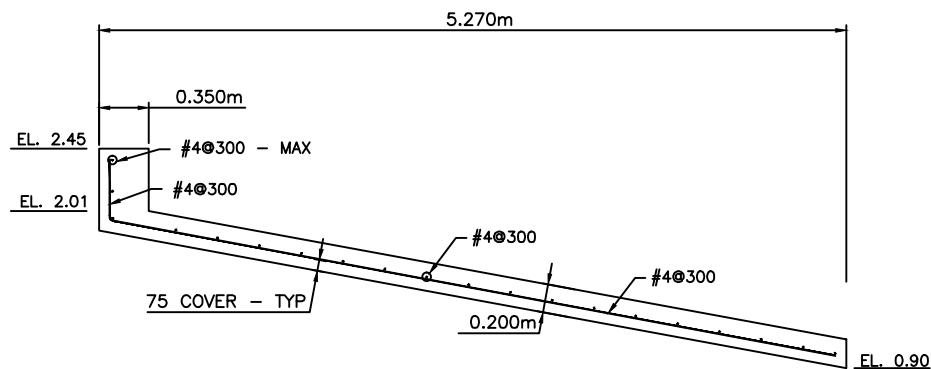

TYPICAL SECTION - REINFORCING
SCALE: 1 : 25

- NOTE:
- * TOP OF WALL ELEVATION +2.45
 - * ALL REINFORCING MUST BE HOT DIPPED GALVANIZED.
 - * MINIMUM COVER FOR REINFORCEMENT SHALL BE 75mm.
 - * 25 CHAMFER ON ALL EXPOSED EDGES UNO

CONSTRUCTION

Reference Drawings

Structures Section

GENERAL NOTES:

ISSUED FOR: CONSTRUCTION 14/08/01

AMENDMENTS:

NO:	REVISION	APP	DATE:

SCALE: AS NOTED

SURVEY

PREPARED BY: DATE:

DESIGN

PREPARED BY: BAP DATE: 23/05/01

CHECKED BY: RRB DATE: 23/05/01

DRAWING

PREPARED BY: JSK DATE: 23/05/01

CHECKED BY: BAP DATE: 23/05/01

APPROVED BY: RRB

PROJECT NUMBER:

61/01/01

PROJECT NAME:

**DOCKYARD
REPLACEMENT FERRY PROJEC
PHASE 1
DOCK CONSTRUCTION**

**DOCKYARD TERRACE
SANDYS PARISH**

DRAWING FILE NO: ACAD R-14

DY-07_Wall-Fender.dwg

SHEET TITLE:

**WALL
FENDER**

SHEET NUMBER: 61/45/01/DY7

REVISION

△

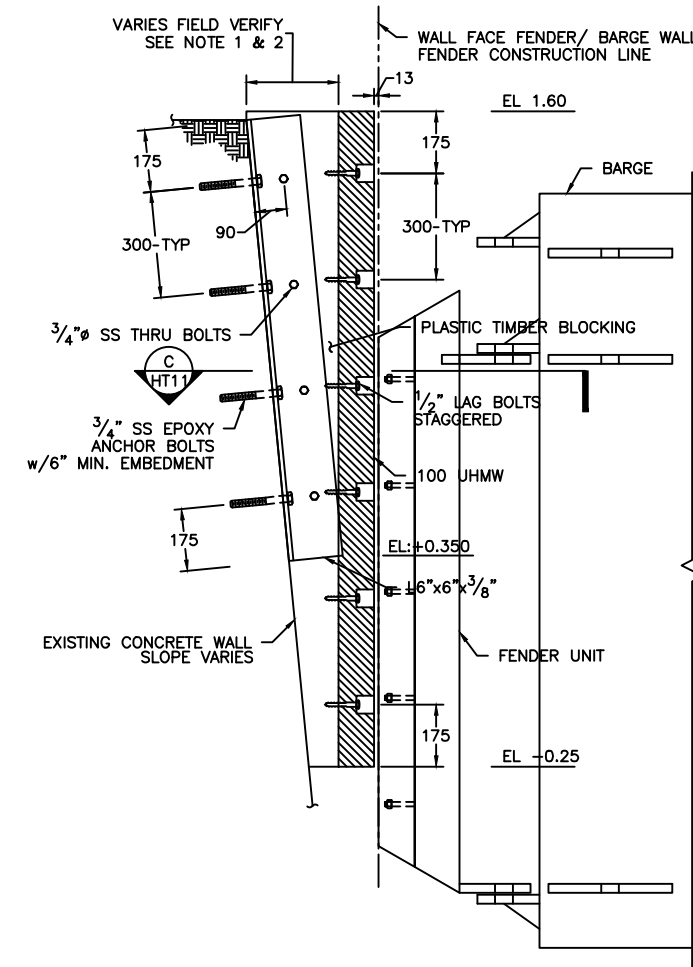

B
WALL FENDER DETAIL
SCALE: 1 : 10

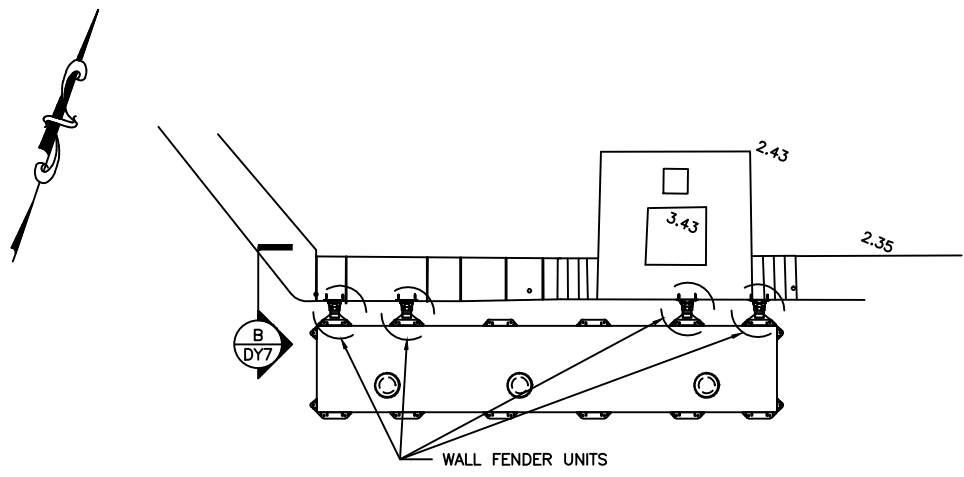

A
PARTIAL PLAN
SCALE: 1 : 50

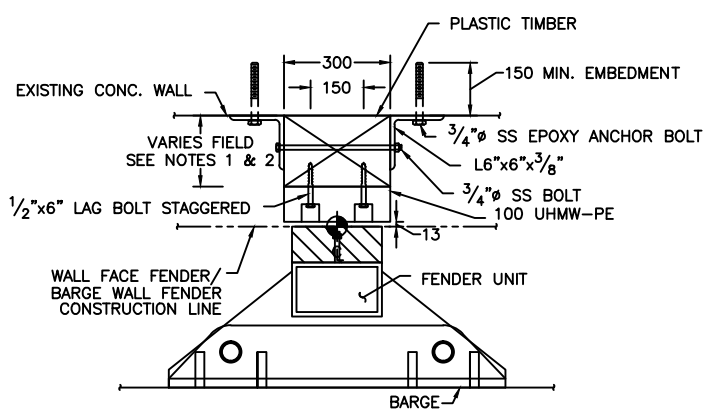

C
WALL FENDER PLAN
SCALE: 1 : 10

- NOTES
1. PLASTIC TIMBER SHALL HAVE MINIMUM THICKNESS OF 100mm @ EL:+0.35.
 2. CONTRACTOR TO FIELD VERIFY SEA WALL SLOPE AND FINAL WALL FACE FENDER/ BARGE WALL FENDER CONSTRUCTION LINE.

CONSTRUCTION
Reference Drawings

Structures Section

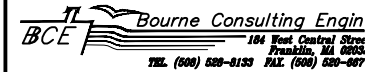

GENERAL NOTES:

ISSUED FOR: CONSTRUCTION 14/08/01

NO:	REVISION	APP	DATE:
Δ	DELETE MRG. DETAILS	RRB	04/01/02

SCALE: AS NOTED

SURVEY
PREPARED BY: DATE:

DESIGN
PREPARED BY: BAP DATE: 23/05/01
CHECKED BY: RRB DATE: 23/05/01

DRAWING
PREPARED BY: JSK DATE: 23/05/01
CHECKED BY: BAP DATE: 23/05/01

APPROVED BY: RRB

PROJECT NUMBER: 61/01/01

PROJECT NAME:
**DOCKYARD
REPLACEMENT FERRY PROJEC
PHASE 1
DOCK CONSTRUCTION**

**DOCKYARD TERRACE
SANDYS PARISH**

DRAWING FILE NO: ACAD R-14
DY-09Mooring Details

SHEET TITLE:
**FENDER
DETAILS**

SHEET NUMBER: 61/45/01/DY9 REVISION: Δ

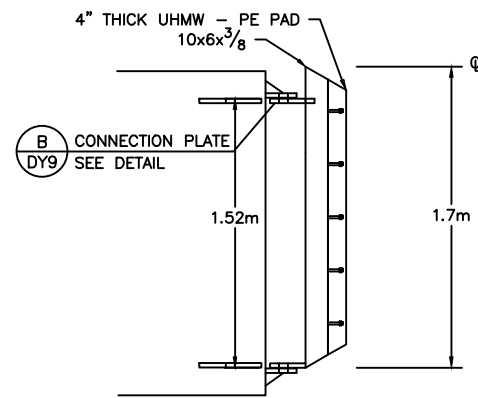

WALL FENDER
SCALE: 1 : 20

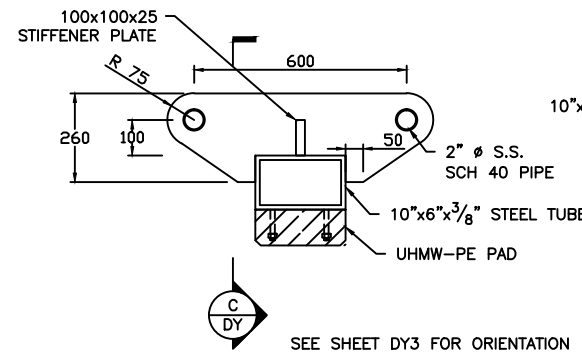

**WALL FENDER
CONNECTION PLATE**
SCALE: 1 : 10

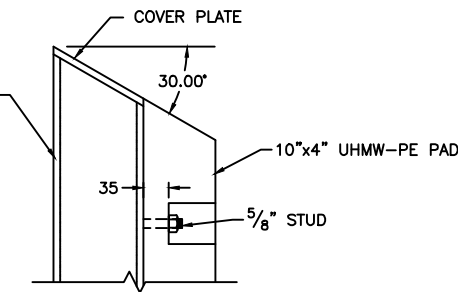

SECTION
SCALE: 1 : 5

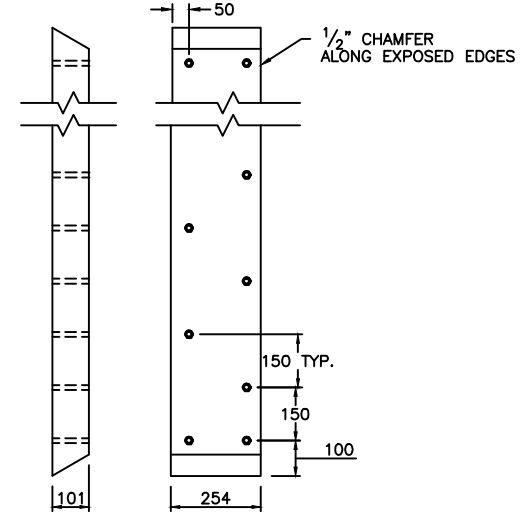

UHMW-PE ELEVATIONS
SCALE: 1 : 10

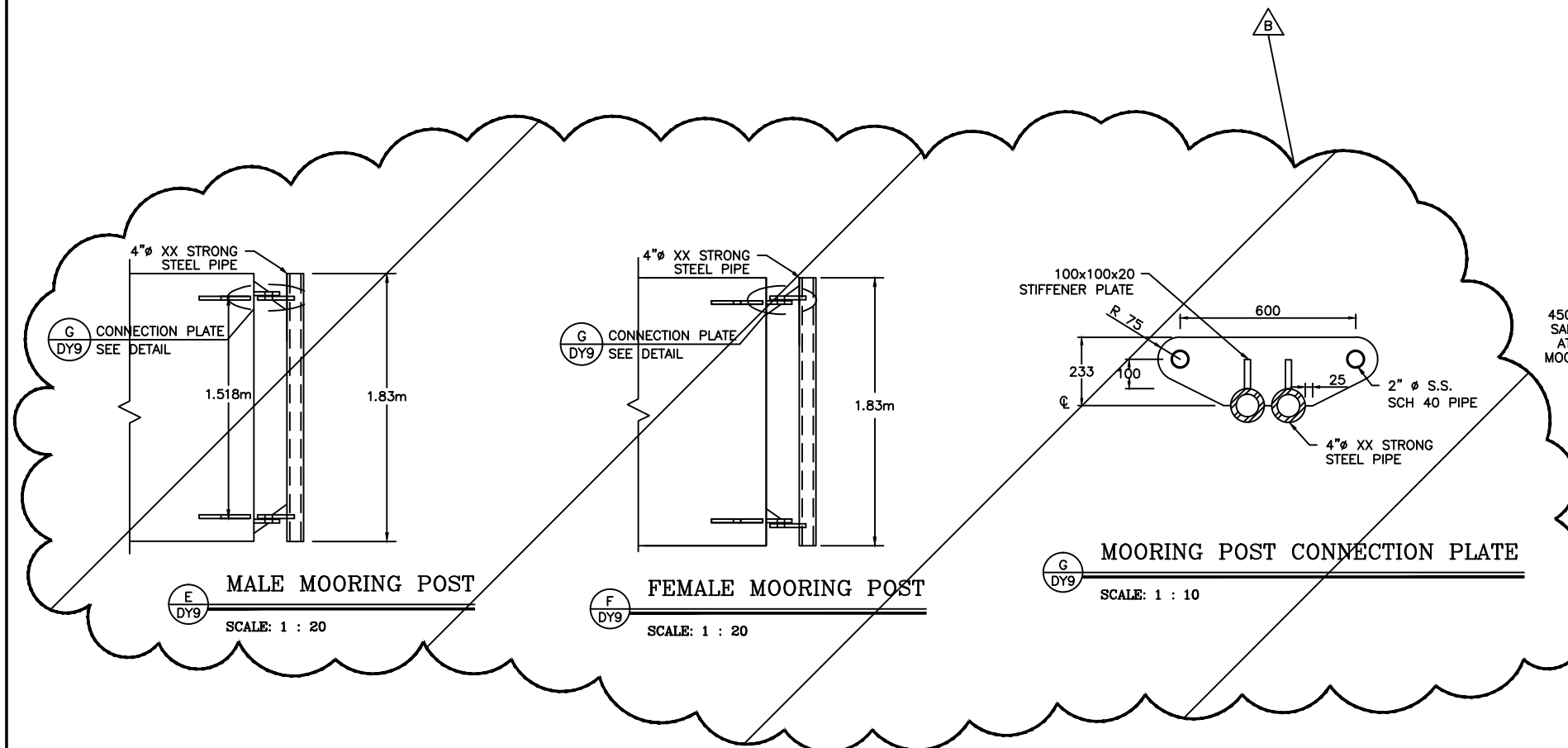

MALE MOORING POST
SCALE: 1 : 20

FEMALE MOORING POST
SCALE: 1 : 20

MOORING POST CONNECTION PLATE
SCALE: 1 : 10

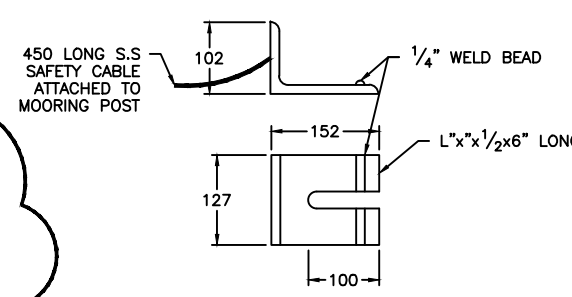

3/4" Ø CHAIN DOG
SCALE: 1 : 5

Reference Drawings CONSTRUCTION

Structures Section

GENERAL NOTES:

ISSUED FOR: CONSTRUCTION 14/08/01

AMENDMENTS:

NO.	REVISION	APP	DATE
1	TYPE I PLATE	RRB	04/01/02

SCALE: AS NOTED

SURVEY

PREPARED BY:	DATE:
BAP	23/05/01

DESIGN

PREPARED BY:	DATE:
BAP	23/05/01

CHECKED BY:

RRB	DATE:
RRB	23/05/01

DRAWING

PREPARED BY:	DATE:
JSK	23/05/01

CHECKED BY:

BAP	DATE:
BAP	23/05/01

APPROVED BY:
RRB

PROJECT NUMBER:
61/01/01

PROJECT NAME:
**DOCKYARD
REPLACEMENT FERRY PROJEC
PHASE 1
DOCK CONSTRUCTION**

**DOCKYARD TERRACE
SANDYS PARISH**

DRAWING FILE NO: ACAD R-14
DY-10 Misc. Details.dwg

SHEET TITLE:
**MISC.
DETAILS**

SHEET NUMBER:
61/45/01/DY10

REVISION
A

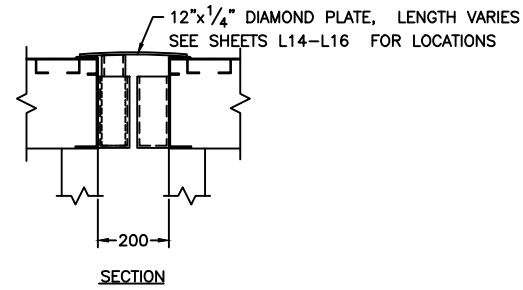

PLATFORM TO PLATFORM TRANSITION PLATE

SCALE: 1 : 10

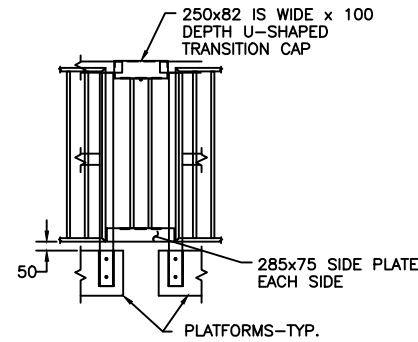

HANDRAIL CONNECTION

SCALE: 1 : 20

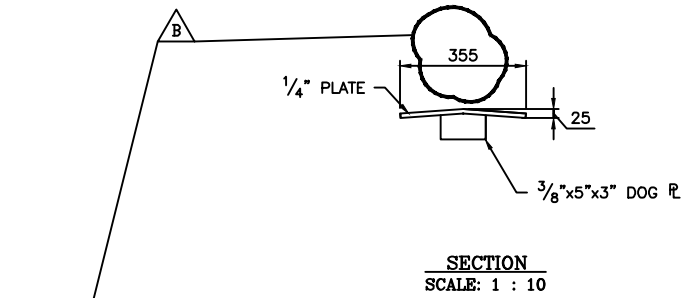

SECTION

SCALE: 1 : 10

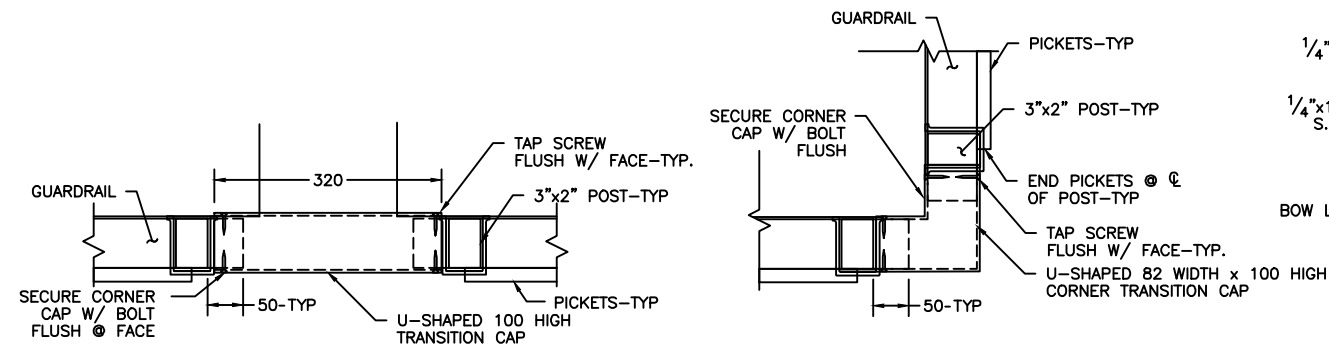

GUARDRAIL TRANSITION

SCALE: 1 : 5

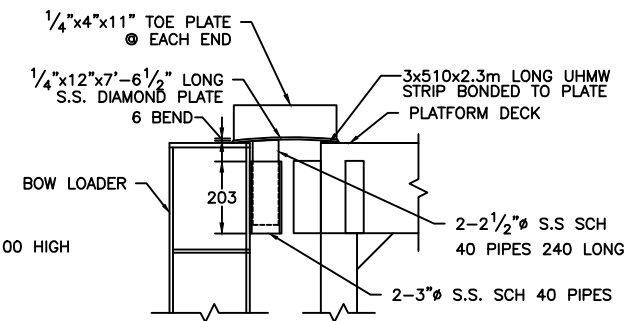

BOW LOADER COVER PLATE

SCALE: 1 : 10

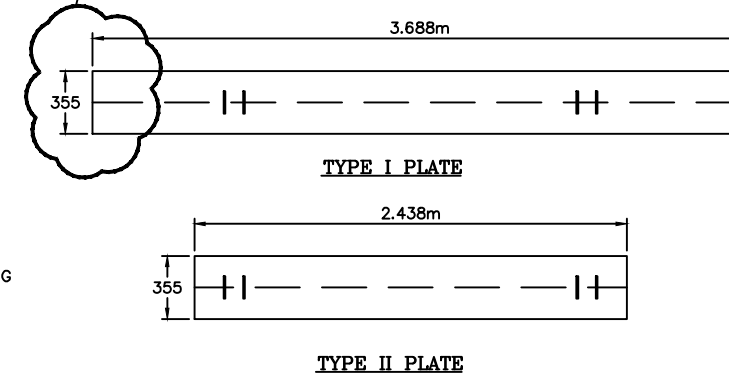

STEEL BARGE COVER PLATES

SCALE: 1 : 20

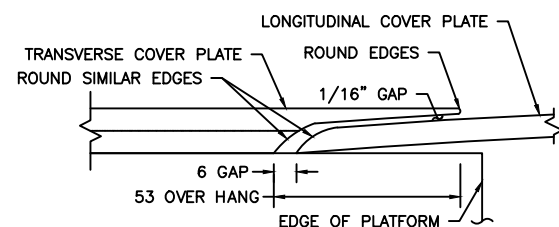

COVER PLATE CROSSING-SECTION

SCALE: 1 : 1

Reference Drawings

CONSTRUCTION

Structures Section



GENERAL NOTES:

ISSUED FOR: CONSTRUCTION 28/11/01

AMENDMENTS:

NO:	REVISION	APP	DATE:
△	SHEET ADDED	RRB	04/01/02
△	COORDINATES REVISED	DGF	22/02/02
△			
△			

SCALE: AS NOTED

SURVEY
PREPARED BY: DATE:

DESIGN
PREPARED BY: BAP DATE: 26/11/01
CHECKED BY: RRB DATE: 28/11/01

DRAWING
PREPARED BY: BAP DATE: 26/11/01
CHECKED BY: RRB DATE: 28/11/01

APPROVED BY: RRB

PROJECT NUMBER:
61/01/01

PROJECT NAME:
**DOCKYARD
REPLACEMENT FERRY PROJECT
PHASE 1
DOCK CONSTRUCTION**

**DOCKYARD TERRACE
SANDYS PARISH**

DRAWING FILE NO: 21378/DY-11.dwg ACAD R-14

SHEET TITLE:
MOORING LAYOUT

SHEET NUMBER: 61/45/01/DY11 REVISION: △

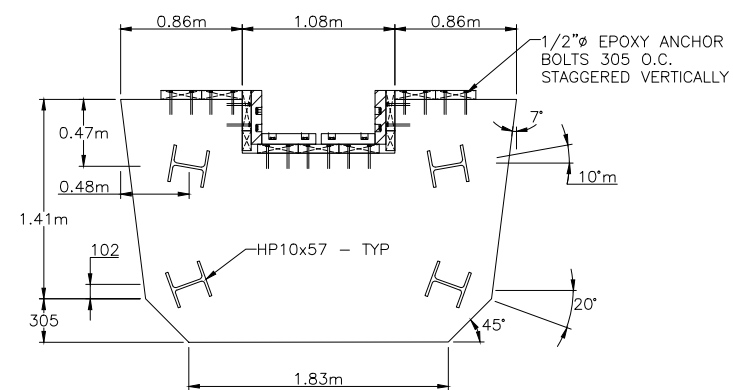

A
MOORING PILE @ -0.2m - PLAN
SCALE: 1 : 25

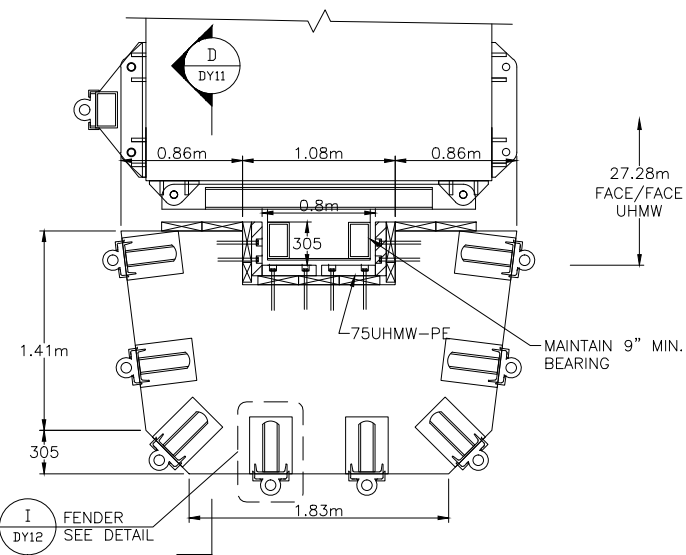

B
MOORING PILE - PLAN
SCALE: 1 : 25

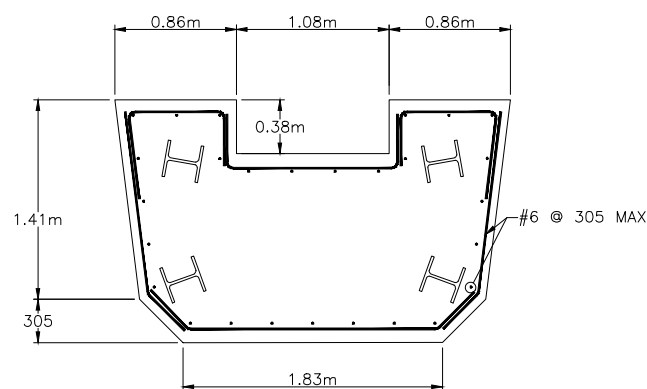

C
REINFORCING - PLAN
SCALE: 1 : 25

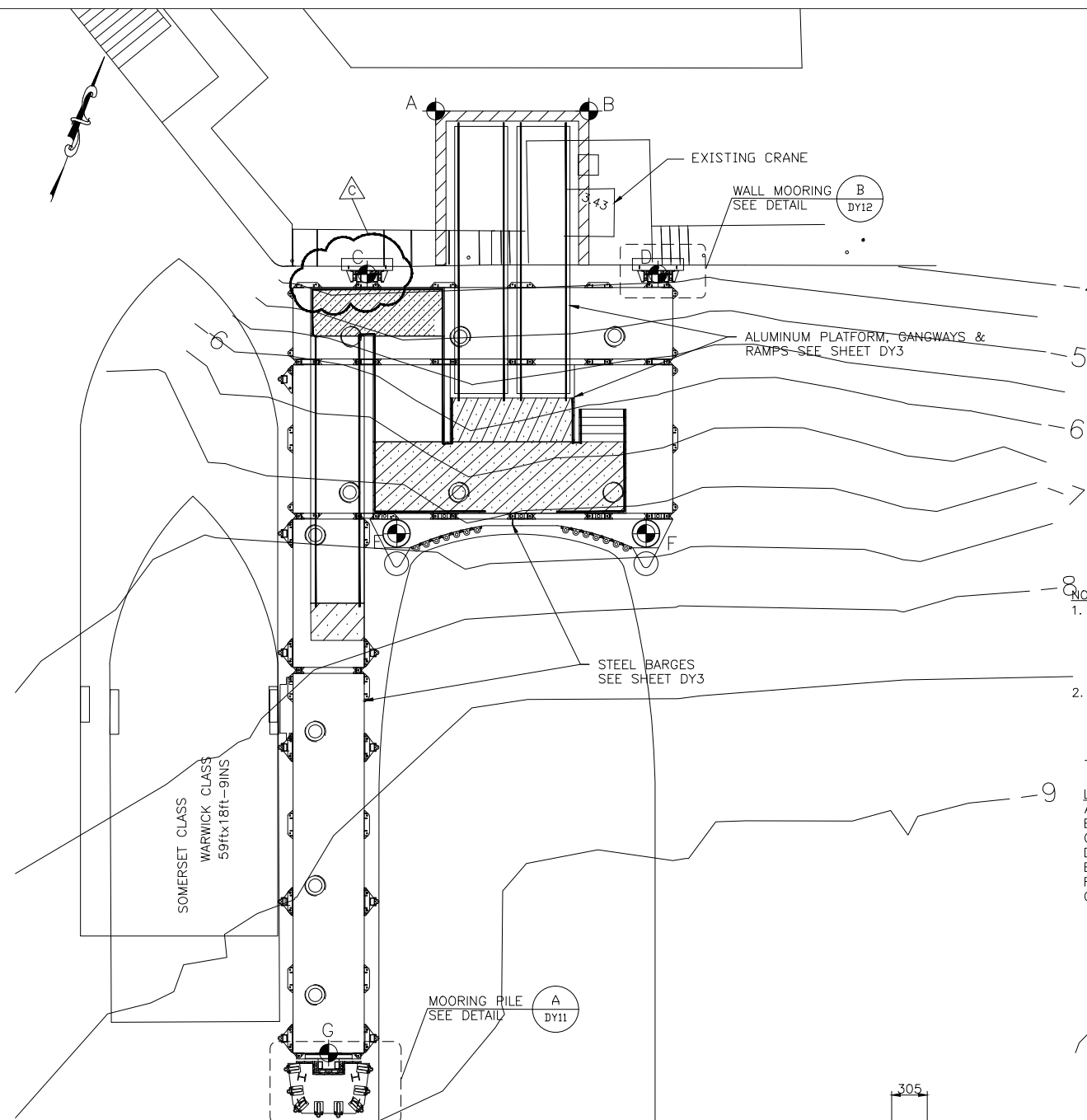

- NOTES
1. WALL FACE FENDER/ WALL BARGE FENDER ALIGNMENT SHALL MATCH ALONG LINE F-H. THE SEAWALL OFFSET DISTANCE WHICH SHALL ACCOUNT FOR WALL FACE SLOPE AND INCONSISTENCIES SHALL BE CONFIRMED PRIOR TO INSTALLATION OF BARGES AND PILES.
 2. ALL PILE LOCATIONS ARE AT THE CENTER. BARGES ARE AT THE CORNERS AND WALL FENDER LOCATIONS ARE AT THE CENTER LINE OF THE UNIT AT THE CONTACT FACE.

TABLE OF COORDINATES

LAYOUT POINTS	NORTHING	EASTING
A. CORNER OF CONCRETE	136200.45	542133.50
B. CORNER OF CONCRETE	136202.45	542138.34
C. EDGE OF FENDER	136194.40	542133.46
D. EDGE OF FENDER	136198.20	542142.66
E. @ BOW LOADER PILE POCKET	136188.30	542137.73
F. @ BOW LOADER PILE POCKET	136189.84	542145.67
G. @ EDGE OF BARGE	136169.25	542142.43

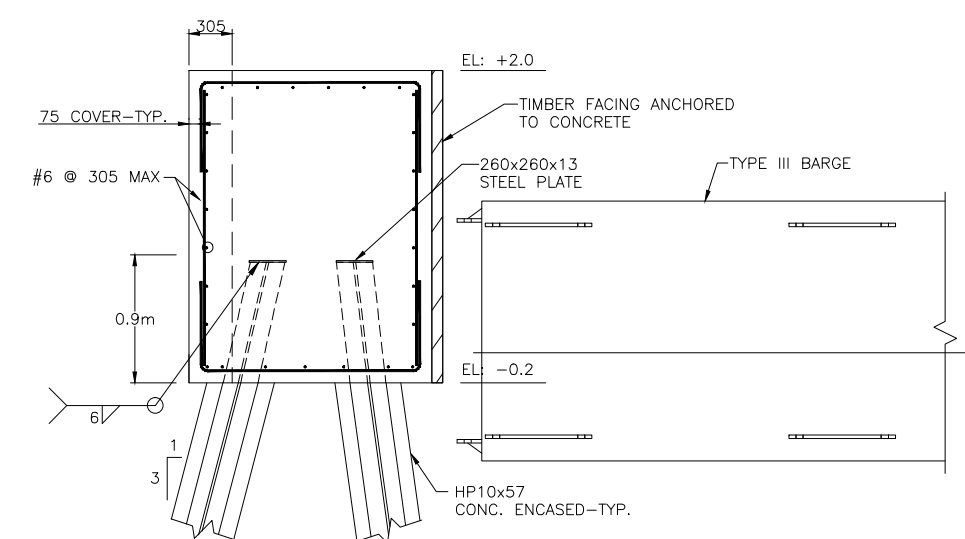

D
MOORING PILE - SECTION
SCALE: 1 : 25

THIS SHEET ADDED 14/12/01

Reference Drawings

Structures Section

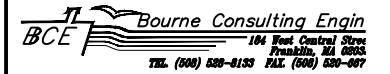

GENERAL NOTES:

ISSUED FOR: CONSTRUCTION 28/11/01

AMENDMENTS:

NO:	REVISION	APP	DATE:
Δ	SHEET ADDED	RRB	04/01/02

SCALE: AS NOTED

SURVEY
PREPARED BY: DATE:

DESIGN
PREPARED BY: BAP DATE: 26/11/01
CHECKED BY: RRB DATE: 28/11/01

DRAWING
PREPARED BY: JSK/BAP DATE: 26/11/01
CHECKED BY: BAP DATE: 28/11/01

APPROVED BY: RRB

PROJECT NUMBER:
61/01/01

PROJECT NAME:
**DOCKYARD
REPLACEMENT FERRY PROJEC**

**DOCK CONSTRUCTION
DOCKYARD TERRACE
SANDYS PARISH**

DRAWING FILE NO: ACAD R-14
21378/DY-12.dwg

SHEET TITLE:
MOORING DETAILS

SHEET NUMBER: 61/45/01 DY12

REVISION
Δ

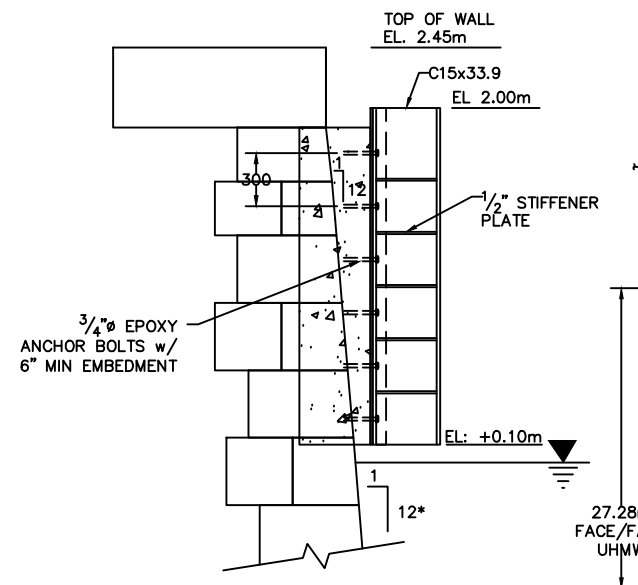

A
WALL MOORING GUIDE-SECTION
SCALE: 1 : 20

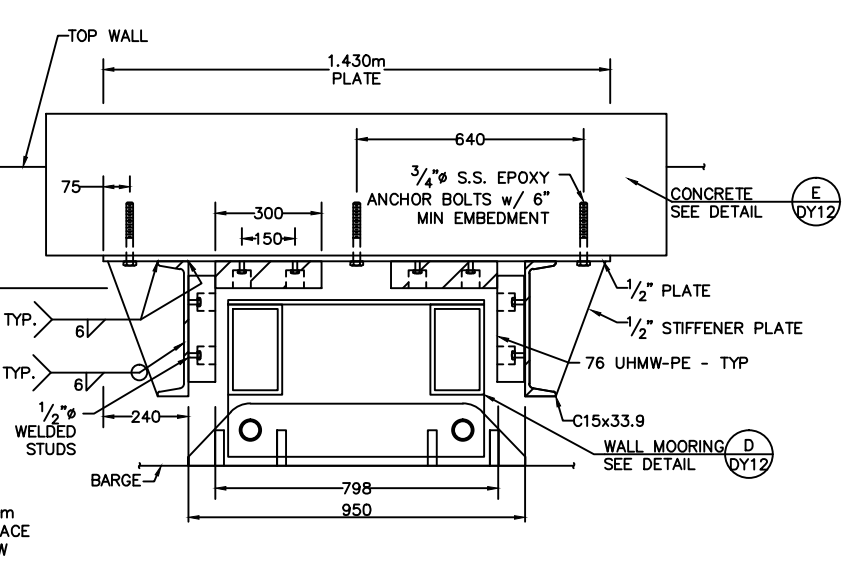

B
WALL MOORING GUIDE-PLAN
SCALE: 1 : 10

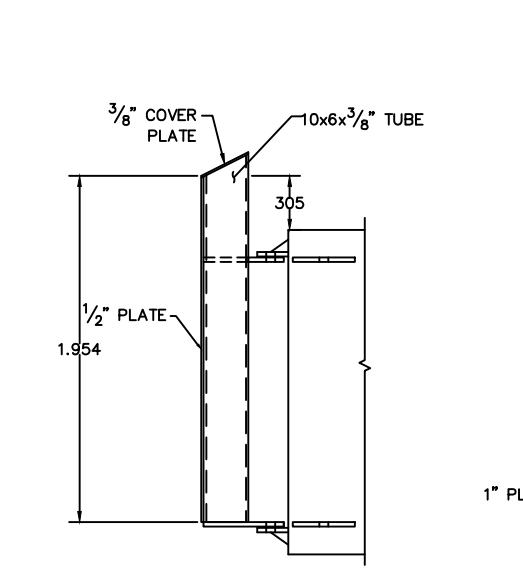

C
MOORING ATTACHMENT @ WALL
SCALE: 1 : 20

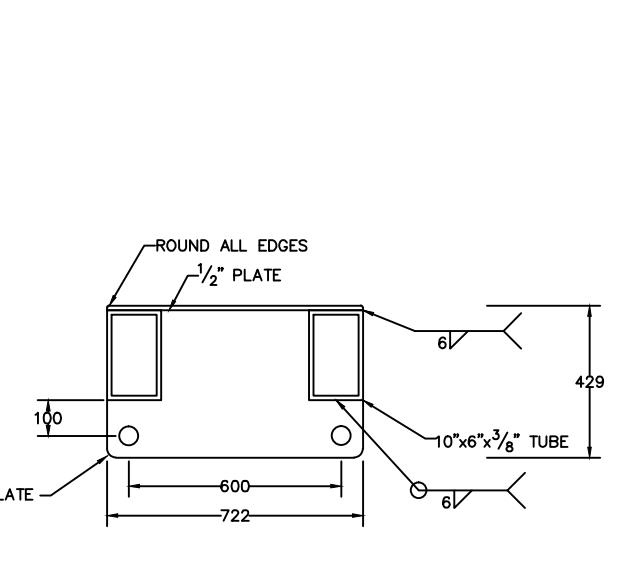

D
WALL MOORING - PLAN
SCALE: 1 : 10

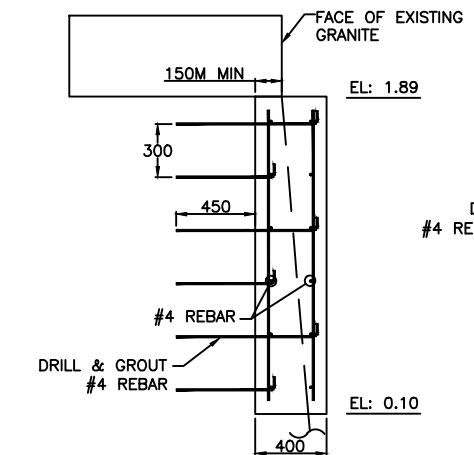

E
MOORING TO WALL
ATTACHMENT-SECTION
SCALE: 1 : 20

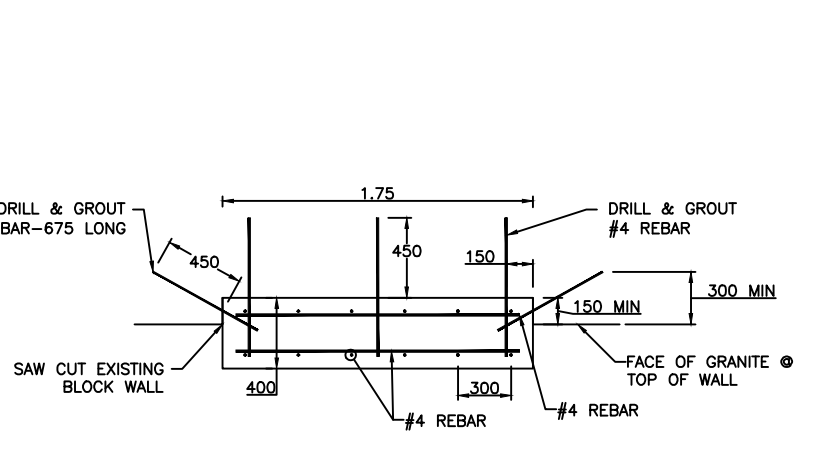

F
MOORING TO WALL
ATTACHMENT-PLAN
SCALE: 1 : 20

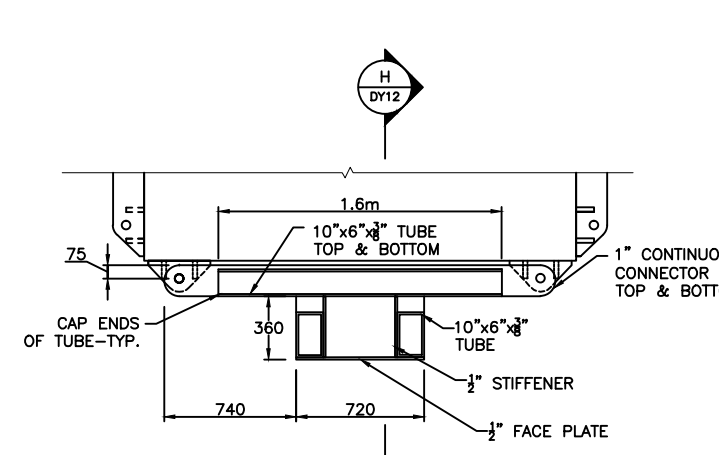

G
BARGE/MOORING DOLPHIN-PLAN
SCALE: 1 : 20

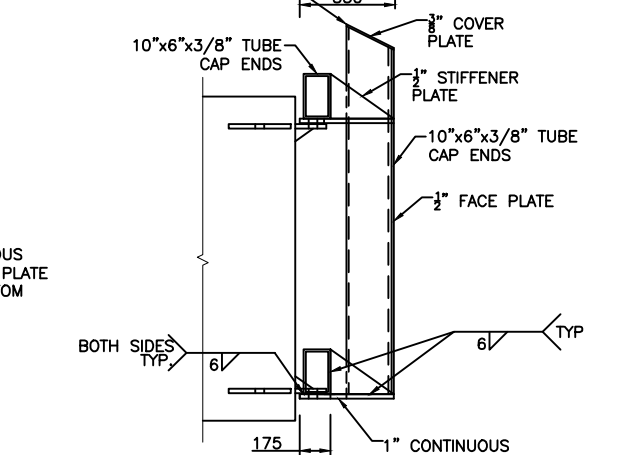

H
BARGE/MOORING DOLPHIN-SECTION
SCALE: 1 : 20

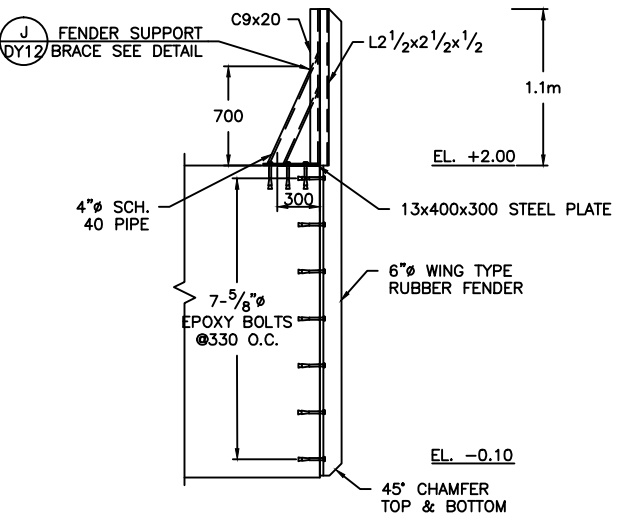

I
FENDER SECTION
SCALE: 1 : 25

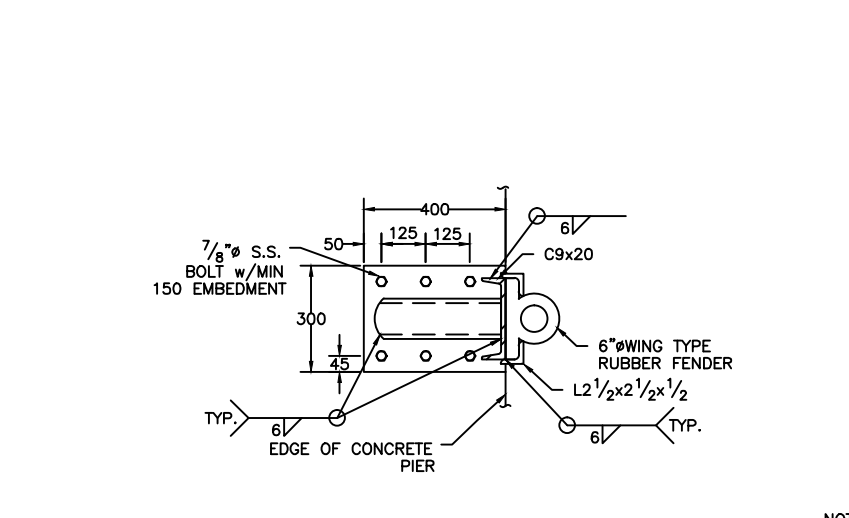

J
FENDER SUPPORT BRACE
SCALE: 1 : 10

- NOTES
1. CONTRACTOR TO FIELD VERIFY SEAWALL SLOPE
 2. STEEL ASSOCIATED WITH MOORING GUIDES AND ATTACHMENTS SHALL BE EPOXY COATED AS SPECIFIED
 3. STEEL FENDER SUPPORT BRACE SHALL BE GALVANIZED

Reference Drawings

Structures Section



- GENERAL NOTES:
1. COORDINATES BASED ON BNG 2000.
 2. ALL ELEVATIONS ARE IN METERS BASED ON ORDNANCE DATUM.
 3. ALL DISTANCES ARE IN METERS.
 4. SURVEY CONTROL SHALL BE PROVIDED TO THE CONTRACTOR BY THE OWNER.

ISSUED FOR: CONSTRUCTION 14/08/01

AMENDMENTS:

NO.	REVISION	APP	DATE:

SCALE: 1 : 200

SURVEY
PREPARED BY: DATE:

DESIGN
PREPARED BY: DATE:
BAP 23/05/01
CHECKED BY: DATE:
RRB 23/05/01

DRAWING
PREPARED BY: DATE:
JSK 23/05/01
CHECKED BY: DATE:
BAP 23/05/01

APPROVED BY:
RRB

PROJECT NUMBER:
61/01/01

PROJECT NAME:
**St. GEORGE'S
REPLACEMENT FERRY PROJECT
PHASE 1
DOCK CONSTRUCTION**

**MARKET WHARF
St. GEORGE'S PARISH**

DRAWING FILE NO: ACAD R-14
SG-1 Existing Cond.dwg

SHEET TITLE:
**EXISTING
CONDITIONS**

SHEET NUMBER: 61/46/01/SG1
REVISION:

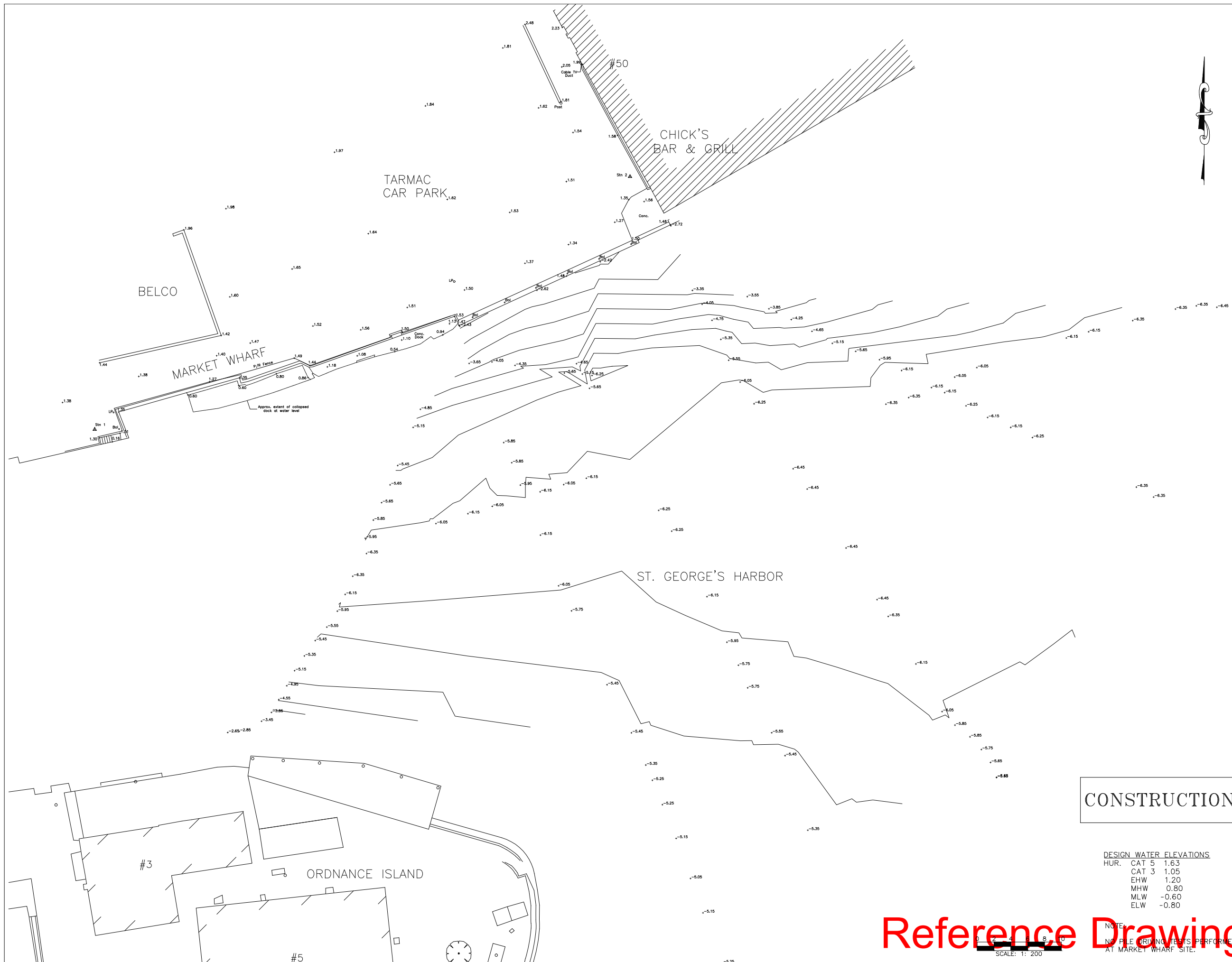

CONSTRUCTION

DESIGN WATER ELEVATIONS

HUR. CAT 5	1.63
CAT 3	1.05
EHW	1.20
MHW	0.80
MLW	-0.60
ELW	-0.80

Reference Drawings

NOTE:
NO PILE DRIVING TESTS PERFORMED
AT MARKET WHARF SITE.

SCALE: 1: 200

GENERAL NOTES:

ISSUED FOR: CONSTRUCTION 14/08/01

AMENDMENTS:

NO:	REVISION	APP	DATE:
1	COVER PLATE	RRB	04/01/02

SCALE: AS NOTED

SURVEY

PREPARED BY: DATE:

DESIGN

PREPARED BY: BAP DATE: 23/05/01

CHECKED BY: RRB

DATE: 23/05/01

DRAWING

PREPARED BY: JSK DATE: 23/05/01

CHECKED BY: BAP

DATE: 23/05/01

APPROVED BY: RRB

PROJECT NUMBER:

61/01/01

PROJECT NAME:

St. GEORGE'S
REPLACEMENT FERRY PROJEC
PHASE 1
DOCK CONSTRUCTION

MARKET WHARF
St. GEORGE'S PARISH

DRAWING FILE NO: ACAD R-14

SG-4 ASSEMBLY-CONN.DWG

SHEET TITLE:

ASSEMBLY
CONNECTION

SHEET NUMBER: 61/46/01/SG4

REVISION

1

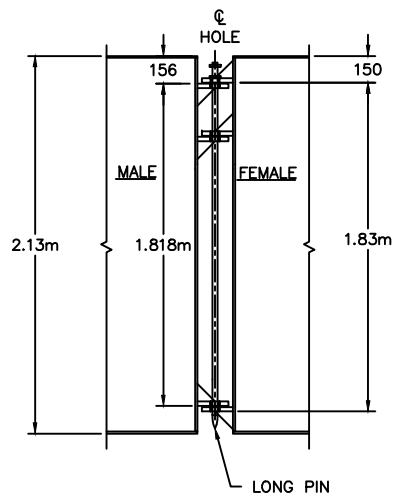

A
SG4
HIGH BARGE CONNECTION
SCALE: 1 : 20

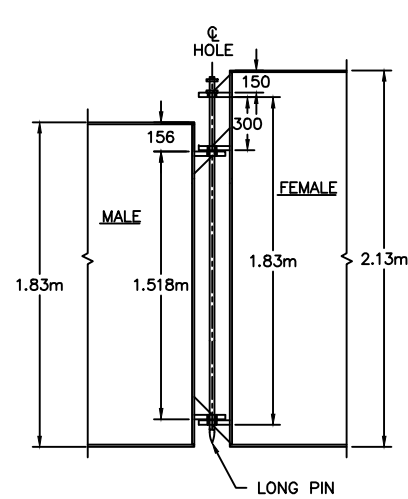

B
SG4
HIGH/LOW BARGE CONNECTION
SCALE: 1 : 20

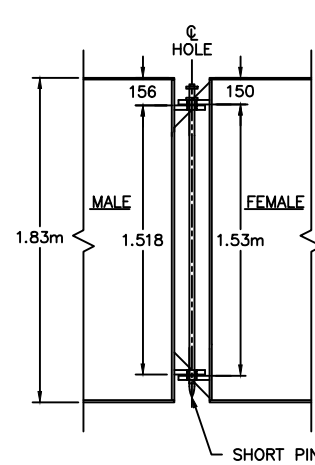

C
SG4
LOW BARGE CONNECTION
PILE GUIDE CONN. SIMILAR
SCALE: 1 : 20

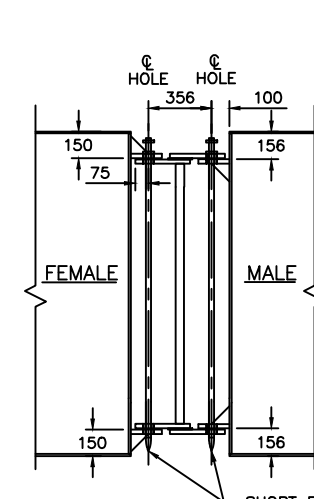

D
SG4
BARGE CONNECTION - DETAIL
SCALE: 1 : 20

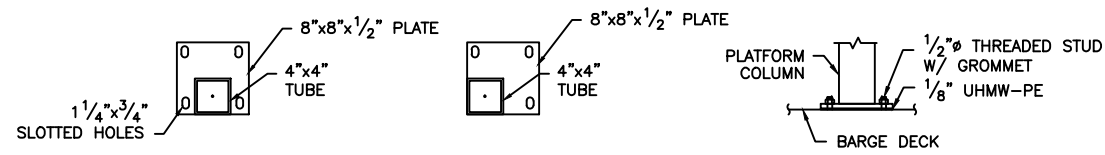

NOTE:
CONNECTION SHALL BE 4-1/2" SS THD' STUDS W/GROMMET,
NUT & WASHER WITH 1/8"x9"x9" UHMW-PE BELOW BASE PLATE

E
SG4
PLATFORM BASE CONNECTION
SCALE: 1 : 10

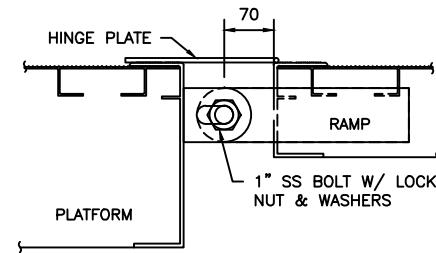

F
SG4
RAMP TO PLATFORM CONNECTION
SCALE: 1 : 5

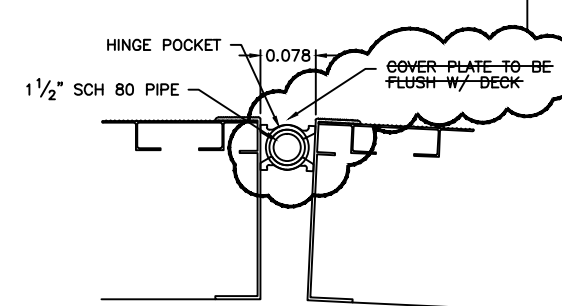

NOTE
SECURE SCH 80 PIPE TO PREVENT LONGITUDINAL MOVEMENT

G
SG4
STANDARD HINGE POCKET CONNECTION
SCALE: 1 : 5

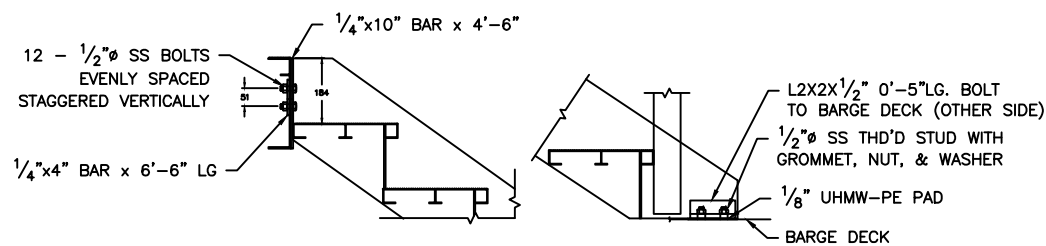

H
SG4
STAIR CONNECTIONS
SCALE: 1 : 10

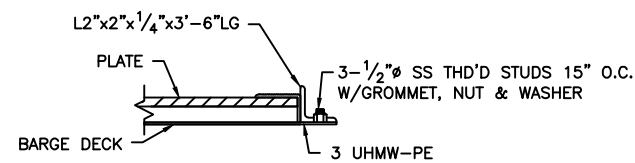

I
SG4
TRANSITION CONNECTION
SCALE: 1 : 5

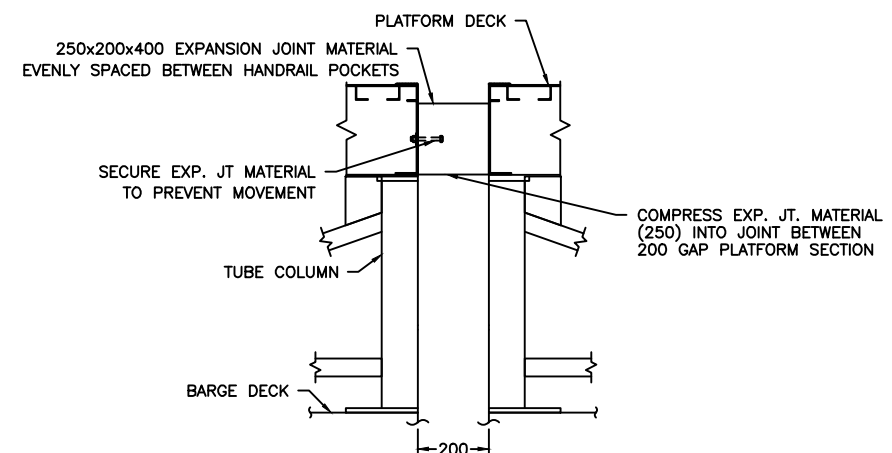

J
SG4
PLATFORM TO PLATFORM CONNECTION
SCALE: 1 : 10

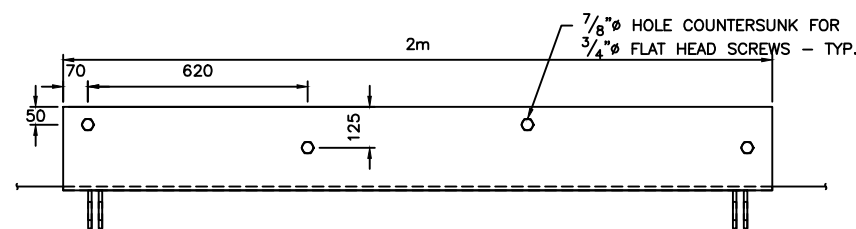

PLAN

K
SG4
GANGWAY LANDSIDE CONNECTION - STANDARD DETAIL
SCALE: 1 : 10

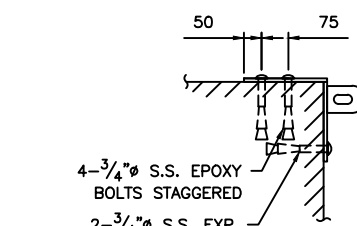

SECTION

Reference Drawings CONSTRUCTION

Structures Section

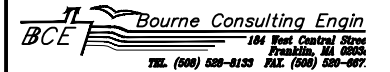

GENERAL NOTES:

ISSUED FOR: CONSTRUCTION 14/08/01

AMENDMENTS:

NO:	REVISION	APP	DATE:
1	HOOP ORIENTATION	RRB	04/01/02
2	BALLAST	BAP	13/05/02

SCALE: AS NOTED

SURVEY

PREPARED BY: DATE:

DESIGN

PREPARED BY: BAP DATE: 23/05/01
CHECKED BY: RRB DATE: 23/05/01

DRAWING

PREPARED BY: JSK DATE: 23/05/01
CHECKED BY: BAP DATE: 23/05/01

APPROVED BY:
RRB

PROJECT NUMBER:
61/01/01

PROJECT NAME:

St. GEORGE'S
REPLACEMENT FERRY PROJEC
PHASE 1
DOCK CONSTRUCTION

MARKET WHARF
St. GEORGE'S PARISH

DRAWING FILE NO: ACAD R-14
SG-5 Ballasting Plan.dwg

SHEET TITLE:

BALLASTING
PLAN

SHEET NUMBER: 61/46/01/SG5 REVISION:

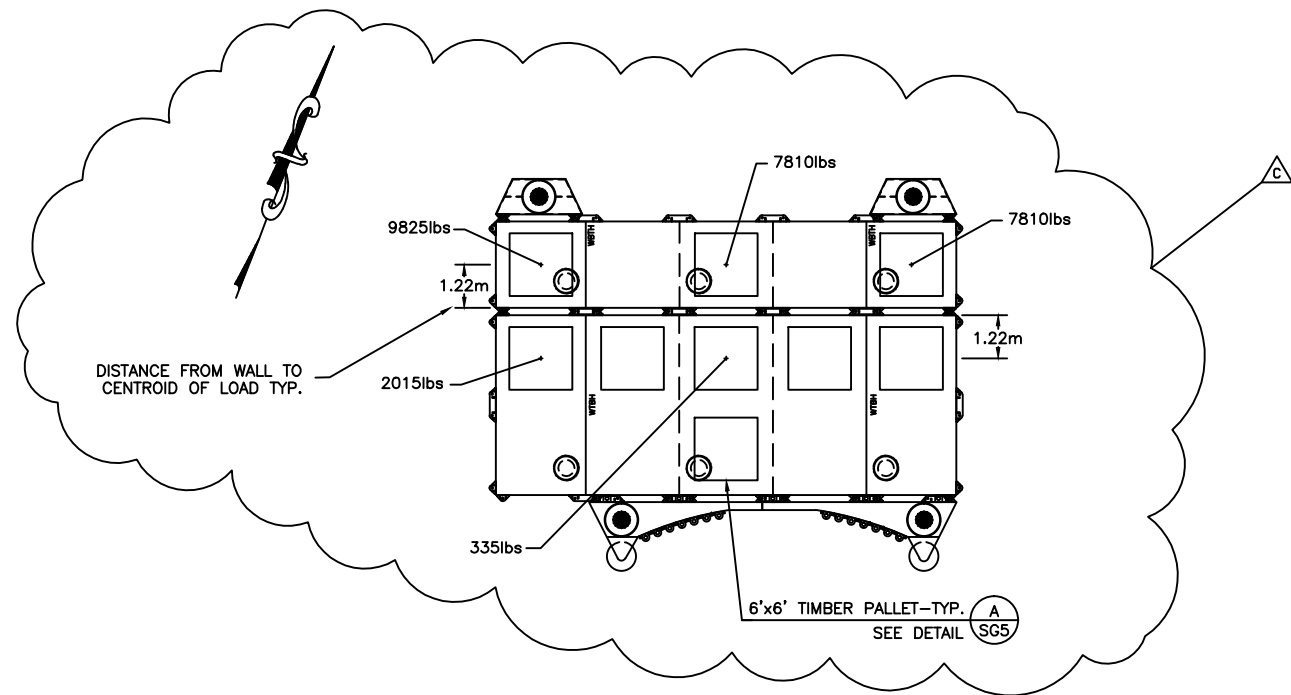

ST. GEORGE'S

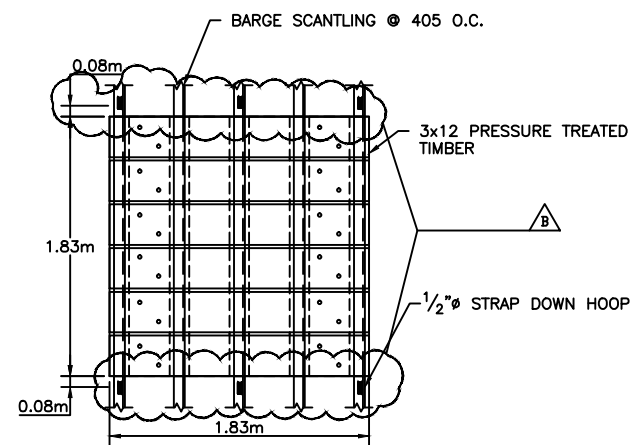

BALLAST PALLET-PLAN

A/SG5

SCALE: 1 : 25

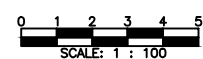

CONSTRUCTION

NOTES:

- BALLAST LOADS ARE SHOWN AT CENTER OF BAY UNLESS NOTED OTHERWISE.
- BALLAST TO BE REMOVEABLE CONCRETE BLOCK OR LEAD.
- BALLAST SHALL BE INSTALLED ON TIMBER PALLETS AT LOCATIONS SHOWN. PALLETS SUPPLIED WITH BARGES.

Reference Drawings

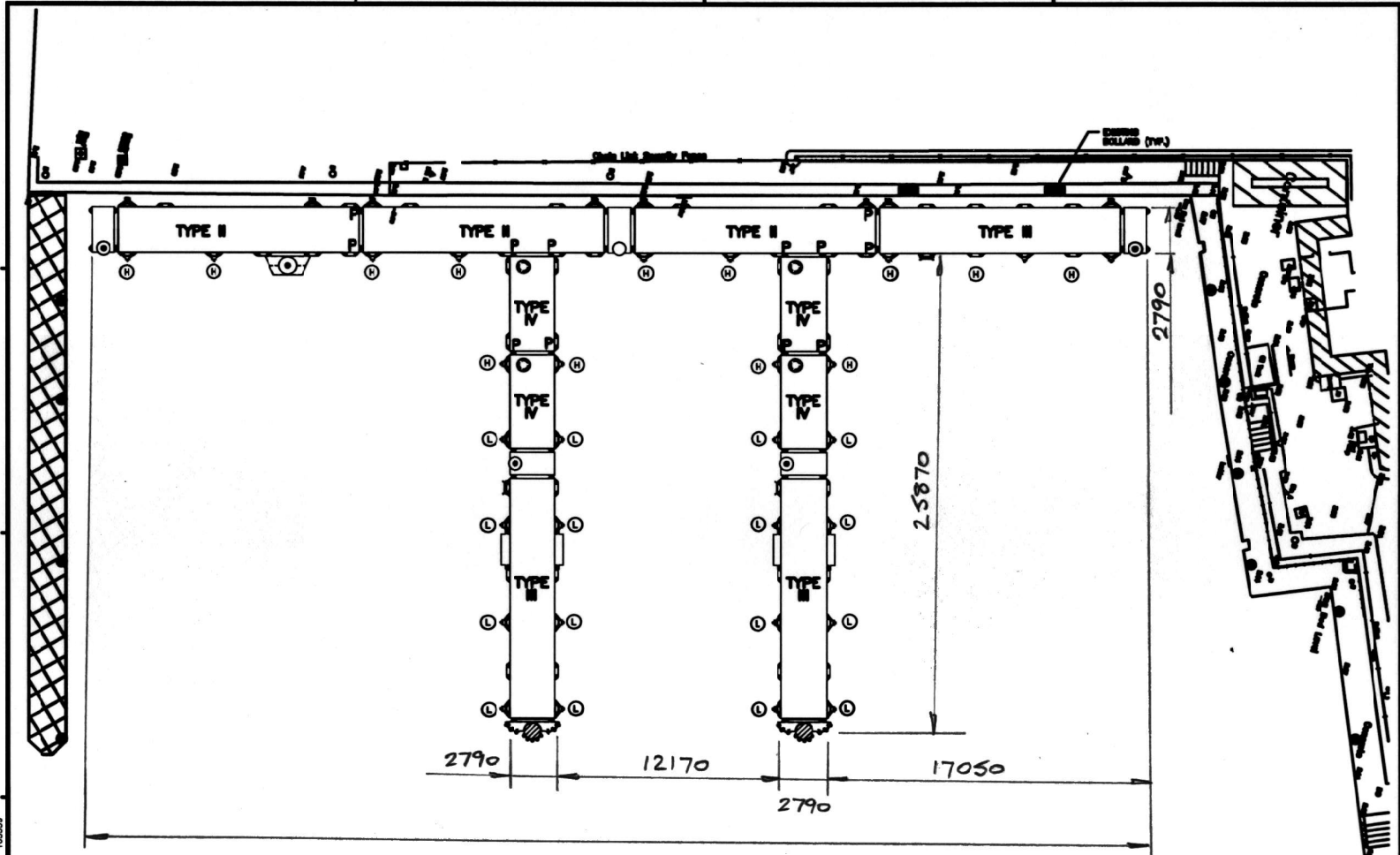

Reference Drawings

BARGE LAYOUT

ALL DIMENSIONS IN MM.

- KEY**
- ⊙ LOW FENDER - SEE SHEET T4.
 - ⊙ HIGH FENDER - SEE SHEET T4.
 - P BARGE TO BARGE PIN REQ'D.
- NOTE:**
1. SEE SHEET T3 FOR BARGE UNITS.
 2. SEE SHEET T4 FOR PILE GUIDE UNITS.
 3. TRANSITION ASSEMBLY TO USE COMMON PIN w/ BARGE FENDER

THE MINISTRY OF WORKS AND ENGINEERING

P.O. Box 10366 Hamilton Bermuda
Phone (441)293-6111

ENGINEERING and OPERATIONS DIVISION
Fax: (441)293-6170

Structures Section

BCE Bermuda Consulting Engineering
10, King George Street, Hamilton, Bermuda
Tel: (441) 293-6170

- GENERAL NOTES:**
1. COORDINATE BASED ON 1985 2000.
 2. ALL ELEVATIONS ARE IN METERS BASED ON CROWNED DATUM.
 3. ALL DISTANCES ARE IN METERS.
 4. SURVEY CONTROL PROVIDED TO THE CONTRACTOR, BY THE OWNER.

ISSUED FOR TENDER 25/05/01

NO.	REVISION	APP.	DATE
1	ISSUED 2 & 3 BY	JJK	14/12/01

SCALE 1 : 100

SURVEY PREPARED BY: DATE:

DESIGN PREPARED BY: DATE: 23/05/01
 SDF
 CHECKED BY: DATE:
 RFB 23/05/01

DESIGN PREPARED BY: DATE: 23/05/01
 JSK
 CHECKED BY: DATE:
 RFB 23/05/01

APPROVED BY: RFB

PROJECT NUMBER: 61/01/01

PROJECT NAME:

HAMILTON-DEPOT REPLACEMENT FERRY PROJECT
 PHASE 1 DOCK CONSTRUCTION
 48 CROW LANE, PEMBROKE PARISH

DRAWING FILE NO: ACAD R-14
 HD-3_Barge-Assembly.dwg

SHEET TITLE: BARGE ASSEMBLY PLAN

SHEET NUMBER: 61/35/01/100



D:_HD-03_Barge-Assembly.dwg 12/27/2001 10:35:58

Structures Section

NOTE: ALL DIMENSIONS ARE IN METERS
UNLESS STATED OTHERWISE.

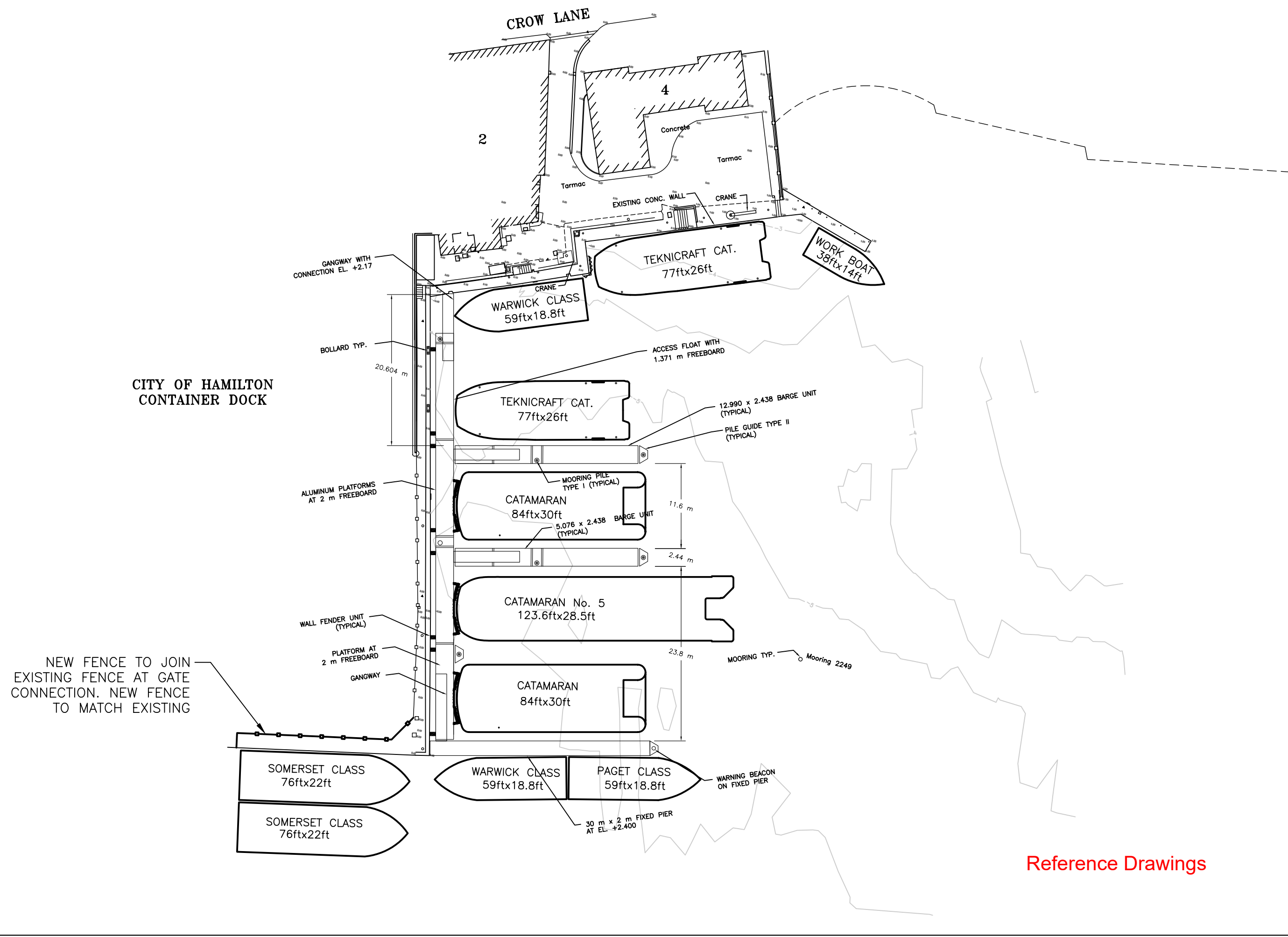

CITY OF HAMILTON
CONTAINER DOCK

NEW FENCE TO JOIN
EXISTING FENCE AT GATE
CONNECTION. NEW FENCE
TO MATCH EXISTING

Reference Drawings

ISSUED FOR: INFORMATION 25/07/06

AMENDMENTS:

NO	REVISION	BY	APP	DATE

SCALE: 1:500

SURVEY
PREPARED BY: KOS/ORS DATE: 14/07/99

DESIGN
PREPARED BY: L. SYLVESTER DATE: 21/07/06
CHECKED BY: DATE:

DRAWING
PREPARED BY: T. HARMER DATE: 24/07/06
CHECKED BY: L. SYLVESTER DATE: 25/07/06

APPROVED BY: DATE:

PROJECT NUMBER:

PROJECT NAME:
**HAMILTON DEPOT
REPLACEMENT
FERRY PROJECT**

**4 CROW LANE
HAMILTON**
SHEET TITLE:
**GENERAL ARRANGEMENT
PLAN**

SHEET NUMBER:
S00

REVISION
▲



Component List

Note: The component list contains items used in the original works. Items may have changed since then, so this list is to be used as a guide only. The Contractor is advised to confirm this list.

There might be missing components or additional spare components stored at Government Quarry.

<u>Components</u>	<u>Hamilton Terminal</u>	<u>Dockyard</u>	<u>From St. Georges</u> Now believed to be at Governments Quarry
Barges			
Type I	2	1	1
Type II	2		1
Type III	3	2	
Type IV	2	1	
Barge Connectors			
Long pins	60	33	25
Short pins	53	30	
Special connector	1		
Pile Guides			
Type I	2		
Type II	2	1	
Type III	1		2
Type IV			
Bow Loader Unit	2	1	1
Fenders			
Type H	2		
Type L	17	10	
Wall fenders			
Fender Panels			
Gangways			
Type I			
Type II	2	2	2
Type III			
Type IV	1		
Ramps			
Type A	2	1	

Transition Ramp	1	1	
HT - Type I	1		
DY - Type I		1	
DY - Stairs		1	
SG - Stairs			1
Platforms			
Type A	4		
HD - Type I			
HD - Type 2			
HD - Type 3			
HT - Type 1	2		
HT - Type 2	1		
Type B		1	1
DY - Type 1		1	
DY - Type 2		1	
SG - Type 1			2

END OF SECTION