

Intended for
Government of Bermuda

Document type
Approval in Principle Report

Date
May, 2019

Document No.
3502-RAM-LB-XX-RP-CB-30001

Revision
P04

Longbird Bridge Replacement, Bermuda Approval in Principle



Knicht Architects



Longbird Bridge Replacement, Bermuda Approval in Principle

Project name **Replacement of Swing Bridge and Longbird Bridge, Bermuda**
Project no. **1620003502**
Recipient **Government of Bermuda**
Document type **Approval in Principle Report**
Version **N/A**
Date **15/05/2019**
Prepared by **R Graham-Ward**
Checked by **J Wharton**
Approved by **S Thompson**
Description **Final – signed version**
Document No. **3502-RAM-LB-XX-RP-CB-30001**
Revision **P04**

Ramboll
Carlton House
Ringwood Road
Woodlands
Southampton
SO40 7HT
United Kingdom

T +44 (0) 238 081 7500
<https://uk.ramboll.com>

Revision	Date	Prepared by	Checked by	Approved by	Description
P01	30/11/2018	RGW	JFRW	SPT	First Issue
P02	19/02/2019	JFRW	WS	SPT	Final – for BDA approval
P03	10/04/2019	JFRW	WS	SPT	BDA comments on section 4.1.9 incorporated
P04	15/05/2019	SPT	JFRW	SPT	Section 4.1.9 amendment to flow/tidal velocity for scour assessment

This report is produced by Ramboll at the request of the client for the purposes detailed herein. This report and accompanying documents are intended solely for the use and benefit of the client for this purpose only and may not be used by or disclosed to, in whole or in part, any other person without the express written consent of Ramboll. Ramboll neither owes nor accepts any duty to any third party and shall not be liable for any loss, damage or expense of whatsoever nature which is caused by their reliance on the information contained in this report.

Ramboll UK Limited
Registered in England & Wales
Company No: 03659970
Registered office:
240 Blackfriars Road
London
SE1 8NW

CONTENTS

1.	HIGHWAY DETAILS	5
1.1	Type of highway	5
1.2	Permitted traffic speed	5
1.3	Existing restrictions	5
2.	SITE DETAILS	5
2.1	Obstacle crossed	5
3.	PROPOSED STRUCTURE	6
3.1	Description of structure and design working life	6
3.2	Structural type	6
3.3	Foundation type	6
3.4	Span arrangements	7
3.5	Articulation arrangements	7
3.6	Classes and levels	7
3.6.1	Consequence class	8
3.6.2	Reliability class	8
3.6.3	Inspection level	8
3.7	Road restraint systems requirements	9
3.8	Proposed arrangements for future maintenance and inspection	10
3.8.1	Traffic management	10
3.8.2	Arrangements for future maintenance and inspection of structure. Access arrangements to structure.	10
3.9	Environment and sustainability	10
3.10	Durability. Materials and finishes	11
3.11	Risks and hazards considered for design, execution, maintenance and demolition. Consultation with and/or agreement from CDM co- ordinator	14
3.12	Estimated cost of proposed structure together with other structural forms considered (including where appropriate proprietary manufactured structure), and the reasons for their rejection (including comparative whole life costs with dates of estimates)	14
3.13	Proposed arrangements for construction	14
3.13.1	Construction of structure	14
3.13.2	Traffic management	15
3.13.3	Service diversions	15
3.13.4	Interface with existing structures	15
4.	DESIGN CRITERIA	16
4.1	Actions	16
4.1.1	Permanent actions	16
4.1.2	Snow, Wind and Thermal actions	16

4.1.3	Actions relating to normal traffic under AW regulations and C&U regulations	16
4.1.4	Actions relating to General Order traffic under STGO regulations	18
4.1.5	Footway or footbridge variable actions	18
4.1.6	Actions relating to Special Order traffic, provision for exceptional abnormal indivisible loads including location of vehicle track on deck cross-section	18
4.1.7	Accidental actions	18
4.1.8	Action during construction	27
4.1.9	Any special action not covered above	27
4.2	Heavy or high load route requirements and arrangements being made to preserve the route, including any provision for future heavier loads or future widening	29
4.3	Headroom provided	29
4.4	Authorities consulted and any special conditions required	29
4.5	Standards and documents listed in the Technical Approval Schedule	30
4.6	Proposed Departures relating to departures from standards given in 4.5	30
4.7	Proposed Departures relating to methods for dealing with aspects not covered by standards in 4.5	30
5.	STRUCTURAL ANALYSIS	30
5.1	Methods of analysis proposed for superstructure, substructure and foundations	30
5.2	Description and diagram of idealised structure to be used for analysis	30
5.3	Assumptions intended for calculation of structural element stiffness	31
5.4	Proposed range of soil parameters to be used in the design of earth retaining elements	31
6.	GEOTECHNICAL CONDITIONS	31
6.1	Acceptance of recommendations of the Geotechnical Design Report to be used in the design and reasons for any proposed changes	31
6.2	Summary of design for highway structure in the Geotechnical Design Report	31
6.3	Differential settlement to be allowed for in the design of the structure	31
6.4	If the Geotechnical Report is not yet available, state when the results are expected and list the sources of information used to justify the preliminary choice of foundations.	32
7.	CHECK	32
7.1	Proposed Category and Design Supervision Level	32
7.2	If Category 3, name of proposed Independent Checker	32
7.3	Erection proposals or temporary works for which Types S and P Proposals will be required, listing structural parts of the permanent structure affected with reasons	32
8.	DRAWINGS AND DOCUMENTS	32
8.1	List of drawings (including numbers) and documents accompanying the submission	32
9.	THE ABOVE IS SUBMITTED FOR ACCEPTANCE	33
10.	THE ABOVE IS REJECTED/AGREED SUBJECT TO THE AMENDMENTS AND CONDITIONS SHOWN BELOW	33

TABLE OF FIGURES

Figure 1 - Representation of Load Model 1	17
Figure 2 - Proposed Evaluation Truck for Bermuda	17
Figure 3 - Proposed Evaluation Lane Load for Bermuda	18
Figure 4 - Diagrams extracted from AASHTO BVCS (2008) illustrating the applied maximum vertical force and associated horizontal force, slamming force, and moment, applied along the length of the span or bridge	21
Figure 5 - Diagrams extracted from AASHTO BVCS (2008) illustrating the applied maximum horizontal force and associated vertical force, slamming force, and moment, applied along the length of the span or bridge	21
Figure 6 - Extract from AASHTO BVCS (2008) Illustrating the Interaction of Waves with the Bridge Structure	21
Figure 7 - Extract from AASHTO BVCS (2008) Showing Wave Force Profiles on Large Elements	24
Figure 8 - Idealised structure diagram	48

TABLE OF TABLES

Table 1 - Consequence class Table B1 from BS EN 1990:2002	8
Table 2 - Inspection level Table B5 from BS EN 1990:2002	8
Table 3 - Design supervision levels from Table B4 from BS EN 1990:2002	9
Table 4 - Material Specification	11
Table 5 - Concrete exposure criteria	13
Table 6 - Vessel Impact Summary	19
Table 7 - Summary Wave Forces Case I	22
Table 8 - Summary of Wave Forces Case II	23
Table 9 - Summary of Wave Forces Case I	23
Table 10 - Summary of Wave Forces Case II	23
Table 11 - Summary of Wave Loads on Abutments and Walls – SLR=0.86m	25
Table 12 - Summary of Wave Loads on Abutments and Walls – SLR=0.0m	25
Table 13 - Spectral accelerations	27

APPENDICES

Appendix 1

Technical Approval Schedule (TAS)

Appendix 2

Diagram of Idealised Structure

Appendix 3

Designer's Risk Assessments

Appendix 4

Drawings

Appendix 5

Geotechnical Report – Highway Structure Summary Information

1. Highway Details

1.1 Type of highway

The existing Longbird Bridge is a three-span structure that lies at the northern end of the Causeway that provides linkage between L.F. Wade International Airport on St David's Island, and Hamilton Parish and the adjoining parishes comprising the rest of the island, to the south west. The original asymmetric slewing bridge was built by the US military in 1953 to connect the Causeway to what was then Kindley Air Force Base. Concerns over the structural condition of the Longbird Bridge caused it to be replaced in 2007 by a pair of fixed Mabey Compact 200 Panel Bridges, one carrying traffic in each direction. These bridges are located to the north-west of the original slewing bridge, which remains at present, but is not open to either vehicular or marine traffic.

The Longbird Bridge Replacement is a fixed single span structure that links St. David's with St. George's and comprises of a single two-lane carriage way and will be constructed on the line of the original Longbird Slewing Bridge. The adjacent temporary Mabey bridges will continue to carry traffic whilst the existing bridge is demolished, and its replacement constructed.

Rev P02 | The Longbird Bridge Replacement's carriageway will have a total width of 7.00 m, two traffic lanes with a width of 3.50 m each, and one footway with a width of 1.20m on the West side of the bridge.

1.2 Permitted traffic speed

Rev P02 | Road over: 50 kph

1.3 Existing restrictions

Not applicable.

2. Site Details

2.1 Obstacle crossed

The bridge spans the channel between Ferry Reach and Castle Harbour.

The existing slewing bridge provides a clear width navigation channel of 25m with an associated air draught of approximately 1.41m above highest astronomical tide (HAT). The replacement bridge will span over the foundations and abutments of the existing structure (which will be demolished to bed level prior to construction of the new bridge) and hence will provide an increased navigable width of 49m. To improve hurricane surge resilience and vessel accessibility the vertical clearance to the replacement bridge has been increased to provide a minimum air draught of 3.31m.

3. PROPOSED STRUCTURE

3.1 Description of structure and design working life

Rev P02

The proposed new structure spans between Ferry Reach and Castle Harbour and provides motorist connectivity between St. David’s Island and the Hamilton parish mainland. The structure will consist of a single span tied arch form. The clear width of the new Longbird Bridge navigation channel is 49m along with a soffit elevation of +4.2m OD adjacent to the abutments and +4.56m OD at mid-span.

The increase in the vertical alignment, to accommodate the increased vertical clearance height, will be provided by approach embankments to the north and south of the structure.

The design life for this structure will be 75 years, except the elements listed below:

Rev P02

- | | |
|------------------------------|------------------------------|
| • Bearings | 50 years design working life |
| • Parapets | 75 years design working life |
| • Waterproofing system | 25 years design working life |
| • Surfacing/Expansion joints | 25 years design working life |

3.2 Structural type

The overall structural form of Longbird Bridge is a pair of tied arches spanning 53.5m supporting a main box girder connected at its edges to the arch’s bottom chord. The arches are formed in steel and are inclined inwards towards the centre of the deck. The arch top chord is a fabricated steel box which varies in depth and width from its widest at abutment to narrowest at arch crown.

The bottom chord of the arch tie is formed from a trapezoidal fabricated steel box of constant dimensions. The arch top chord and bottom chord are connected by steel plate hangers. The top and bottom chords are stiffened by plate diaphragms at hanger positions. The inner face of the arch chords and hangers are protected from errant traffic by a combination of a VRS system and high containment kerbs.

Rev P02

The deck comprises a main steel box girder with a curved soffit, which tapers toward its outer edges to its connection to the bottom chord and incorporates a grillage of plated transverse steel diaphragms. Transverse diaphragms are provided between hanger positions. The upper face of this box supports the running surface of the carriageway and comprises a reinforced concrete deck slab spanning between, and acting compositely with, the transverse diaphragms.

Rev P02

There is a pedestrian footpath on the west side of the bridge. The footway is formed from a fabricated box structure which cantilevers from the outer edge of the arch bottom chord and is stiffened by transverse diaphragms.

Rev P02

3.3 Foundation type

The bridge terminates at the abutments located on the north and south sides of the navigable channel. The abutments will be cast in-situ reinforced concrete cellular structures backfilled with granular fill and connected to the driven steel tubular piles with reinforced concrete pile caps. The

top of pile caps are located 0.5m below lowest astronomical tide level.

Rev P02

During the Feasibility stage in Phase II, an approximate bed profile was determined from chart information derived from the Navionics website. This approximate bed profile derived has indicated that fill will be required between the pile cap soffit and the bed. This fill will be retained by permanent sheet piles around the perimeter of the pile cap, cut off at top of pile cap level in the permanent condition.

Wing walls are provided on both sides of each abutment. Longer and taller wing walls are required on the east side of the bridge and these wing walls will have their own piled foundations.

For further details of the bridge superstructure and substructure please refer to the layout drawings provided in Appendix 4 of this report.

3.4 Span arrangements

The Longbird Replacement Bridge is a single span tied-arch structure and has been designed to span over the footprint of the existing bridge's foundations.

3.5 Articulation arrangements

Rev P02

The bridge is articulated conventionally with Pot or Spherical bearings located beneath a transverse diaphragm between the arch bifurcation sections, and positioned along the centreline of the arch bottom chord, at each abutment. Provision for jacking for bearing replacement is provided in board of the permanent bearings. Under hurricane tidal surge loading the bridge is subject to significant transverse moments. The moment from this extreme event loading is resisted by an arrangement of bearings and tie-down restraint located at each bearing position at both north-east and south-west abutments.

Rev P02

3.6 Classes and levels

The superstructure and the substructures including piled foundations are Consultant designed elements. The whole structure category as defined in BD2 is Category 3.

Classes are based on the assumed consequences of failure and the exposure of the construction works to hazard.

3.6.1 Consequence class

The whole structure has been classed as CC2; shown in Table 1 below.

Table 1 - Consequence class Table B1 from BS EN 1990:2002

Consequences Class	Description	Examples of buildings and civil engineering works
CC3	High consequence for loss of human life, <i>or</i> economic, social or environmental consequences very great	Grandstands, public buildings where consequences of failure are high (e.g. a concert hall)
CC2	Medium consequence for loss of human life, economic, social or environmental consequences considerable	Residential and office buildings, public buildings where consequences of failure are medium (e.g. an office building)
CC1	Low consequence for loss of human life, <i>and</i> economic, social or environmental consequences small or negligible	Agricultural buildings where people do not normally enter (e.g. storage buildings), greenhouses

3.6.2 Reliability class

Reliability classes are represented by beta indexes as per Table B2 in Annex B of BS EN 1990. The indexes allow for moderate differentiation in the partial factors for actions and resistances. They correspond with the Consequence Classes as per Clause B3.2(2) of BS EN 1990.

The whole structure has been classed as a minimum as RC2 with an associated multiplication factor for actions KFI=1.0.

3.6.3 Inspection level

Inspection levels define the inspection characteristics and requirements as shown in Table 2 below.

The inspection level for the whole structure is IL2

Table 2 - Inspection level Table B5 from BS EN 1990:2002

Inspection Levels	Characteristics	Requirements
IL3 Relating to RC3	Extended inspection	Third party inspection
IL2 Relating to RC2	Normal inspection	Inspection in accordance with the procedures of the organisation
IL1 Relating to RC1	Normal inspection	Self inspection

Design supervision level

The design supervision level for the whole structure is considered as DSL3 as shown in Table 3 below.

Table 3 - Design supervision levels from Table B4 from BS EN 1990:2002

Design Supervision Levels	Characteristics	Minimum recommended requirements for checking of calculations, drawings and specifications
DSL3 relating to RC3	Extended supervision	Third party checking : Checking performed by an organisation different from that which has prepared the design
DSL2 relating to RC2	Normal supervision	Checking by different persons than those originally responsible and in accordance with the procedure of the organisation.
DSL1 Relating to RC1	Normal supervision	Self-checking: Checking performed by the person who has prepared the design

Execution Class

EXC3 for Superstructure steelwork in accordance with EN 1090-2 Table B.3.

Rev P02

Execution Class EXC3 for Substructure and Superstructure concrete works in accordance with Highways England Specification Appendix 1701.

3.7 Road restraint systems requirements

Pedestrian parapets on the bridge superstructure will be a bespoke lattice grille structure made of wide flat steel bars, ensuring a vertical gap of not more than 110mm width. The vertical orientation of the bars will prevent them from being climbed.

At a height of 1.15 m the parapets along with the pedestrian decks will be finished by a longitudinal handrail made in stainless steel.

A vehicle restraint system (VRS) will also be installed on Longbird Bridge. At this stage, the proposed VRS is a tubular CHS that is set with its centroid 600mm above the adjacent carriageway and set back a minimum of 600mm from the traffic face. Additional protection will be provided by high containment kerbs on each side of the carriageway.

The proposed load criteria and impact force on the VRS, and the design guidance used to ascertain the average impact force applied to the CHS are listed below:

- TD 19/06 – Requirements for Road Restraint Systems.
- TD 27/05 – Road Geometry Links – Cross-sections and Headrooms
- BS EN 1991 and National Annex
- BS EN 1317 – 2:2010 Road Restraint Systems. Performance Classes, Impact Test Acceptance Criteria and Test Methods for Safety Barriers Including Vehicle Parapets.
- BS 7818:1995 – Specification for Pedestrian Restraint Systems in Metal
- Manual of Contract Documents for Highway Works Specification for Highway Works Volume 1 – Series 400 – Road Restraint Systems

3.8 Proposed arrangements for future maintenance and inspection

3.8.1 Traffic management

No specific traffic management arrangements are envisaged for the maintenance and inspection of the internal deck box girder voids, arch bottom chord steelwork, deck box girder soffit and carriageway and footway surfaces.

In order to provide access for maintenance and inspection of the arch top chord and hangers, single lane closures of the carriageway and associated closures of the footway (where relevant), adjacent to the arch being inspected, will be required. Temporary traffic signals will then be required to provide safe, controlled flow of traffic to and from the Causeway, whilst the single lane closure is in operation.

3.8.2 Arrangements for future maintenance and inspection of structure. Access arrangements to structure.

Inspection and maintenance of external surfaces of the bridge deck's structural steelwork will be possible by means of temporary barges and access scaffolding. The inspection of the arch top chord and hangers will be achieved using mobile elevated working platforms operating from the bridge deck.

Internal access man-ways generally will be provided through the length of the deck box girder to allow access for inspection and maintenance of interior surfaces. This will require confined space access procedures. Access within the box will be provided wherever possible; portholes or smaller holes for endoscope will be provided for critical areas where man access is impracticable in order to permit visual inspection only. Inaccessible internal surfaces of structural steelwork, such as arch top and bottom chord elements and footway box structures will be effectively sealed by welding.

There will be single access to the deck box girder from either the north or south abutment access galleries, through sealed cover plates in the deck box girders end diaphragm. It is proposed to seal the cover plates at all locations to limit the exposure to air, moisture and contaminants. Access galleries will be provided at the bridge abutments for inspection and maintenance of the bridge bearings and allowance will be made within the design for temporary jacking/support points to enable replacement of all bearings. A stepped access way for inspection and maintenance personnel, from the approach embankment verge on the east side of the bridge, down into the abutment access gallery, will be provided at both the north and south abutments.

3.9 Environment and sustainability

Unsustainable and high embodied energy materials have been avoided where possible. The designed solution will be developed to minimise material usage in the superstructure and foundations. The steel for the superstructure can be readily recycled at the end of its working life and is likely to already contain a recycled component. The bridge superstructure will be fabricated off site in the controlled environment to minimise impact on the environment.

3.10 Durability. Materials and finishes

Table 4 - Material Specification

<p>Structural Steelwork – superstructure</p>	<p>Steel Grade S355 to BS EN 10025-2:2004 will be used for the bridge superstructures. As an alternative, ASTM A 709/A 709M grade 50 steel, or other equivalent, may be used. Where necessary steel plate shall comply with the requirements for improved deformation properties perpendicular to the surface of the product in accordance with BS EN 10164.</p> <p>In case of ASTM specified materials the yield and tensile strength shall be equal or greater than Steel Grade S355 to BS EN 10025-2.</p> <p>Inside the central cell of the bridge deck superstructure, it is proposed to paint all internal steel surfaces. These surfaces will be readily accessed for maintenance painting in the future.</p> <p>There will inevitably be some areas of the superstructure steelwork, arch top and bottom chords for example, that will become inaccessible as fabrication advances which will result in irreparable damage to internal paintwork during the welding process which cannot then be repaired as part of the fabrication nor repainted as part of the maintenance regime. Where this occurs, sacrificial steel will be provided.</p> <p>The thickness of the sacrificial steel is dependent on the corrosivity category. Clause NA.2.14 a) of UK National Annex to BS EN 1993-2 provides guidance on sacrificial thickness allowances for the various atmospheric corrosion classes.</p> <p>An appropriate allowance for a humid subtropical climate will be considered. The internal boxes will generally be sealed with only occasional opening and venting for inspection and maintenance access through sealed access cover plates. This will significantly limit the exposure to air, moisture and contaminants. In accordance with Annex C of BS EN ISO 9223 Table C.1, corrosivity category C3 is proposed for the internal environment of the box elements of Longbird Bridge Replacement.</p> <p>The additional sacrificial thickness of steel elements will be considered in accordance with Clause NA.2.14 a) and Table NA.1 of UK National Annex to BS EN 1993-2. It is proposed that steel with sacrificial steel allowance of 4.0mm appropriate to corrosivity category C3 is adopted for all internal unpainted and inaccessible surfaces.</p>
<p>Steel driven piles</p>	<p>Steel grade S355 to BS EN 10025-2:2004 will be used for the steel tubular piles. As an alternative ASTM A252 Grade 3 (Mod) may be used. The piles will have a design life of 75 years. The interior face and exterior face of the piles will include a sacrificial</p>

Rev P02

Rev P02

	<p>steel thickness of 2.6mm, which is the estimated loss of section thickness (mm) over a 75 year design life when fully submerged in sea water as specified in Table NA.1 of NA to BS EN 1993-5. In case of ASTM specified materials the yield and tensile strength shall be equal or greater than Steel Grade S355 to BS EN 10025-2.</p>
Parapets/Bearing and tie down pins	<p>Stainless steel grade 1.4404 or 1.4462 to BS EN 10088-2.</p> <p>As an alternative stainless steel grade S31603 or S32205 to ASTM A959 may be used.</p> <p>In case of ASTM specified materials the yield and tensile strength shall be equal or greater than the steel materials specified in BS EN 10088-2.</p>
Access Grating	<p>Stainless steel grade 1.4404 to BS EN 10088-2.</p> <p>As an alternative stainless steel grade S31603 to ASTM A959 may be used.</p> <p>In case of ASTM specified materials the yield and tensile strength shall be equal or greater than the steel materials specified in BS EN 10088-2.</p>
Concrete	<p>Grade C40/50 to BS 8500 (20mm max aggregate size).</p> <p>As an alternative Class P with compressive cylinder strength $f'_c = 5.8 \text{ ksi} (=40 \text{ MPa})$ to AASHTO LRFD Bridge Design Specifications (20mm max aggregate size) may be used.</p> <p>In case of concrete material specified to AASHTO the nominal concrete cover shall be specified to BS 8500.</p>
Reinforcement	<p>Steel reinforcing bars shall be grade 500B or 500C ribbed bars to BS 4449:2009, to be produced by the hot rolled method.</p> <p>Alternatively, the reinforcement should conform to ASTM A615 Grade 60 reinforcement with a minimum yield strength of 60,000 pounds per square inch (psi) which is equal to 414 MPa.</p> <p>Reinforcement to be hot dip galvanised to BS EN ISO 1461 or Class 2 standard as per ASTM standard A 767; or zinc metal sprayed to BS EN ISO 17834.</p> <p>The yield strength of reinforcement to be used in the design calculation is to be 414 MPa in order to suit the selection of reinforcement specified to either BS or ASTM.</p>

<p>Surface Treatment – Waterproofing</p>	<p>The top surface of the concrete deck slab will be protected by a proprietary waterproofing system to 2000 Series of SHW (Specification of Highways Works).</p> <p>All buried concrete surfaces and the rear face of the abutments down to the level of the deck soffit shall receive two coats of bituminous paint in accordance with Clause 2030 of SHW.</p>
<p>Paint Protective Coatings</p>	<p>All exterior steelwork surfaces and internal surfaces of box sections accessible for maintenance will be painted with a Type II approved paint system complying with Series 1900 of the Specification for Highways Works appropriate to a Marine Environment with difficult access with 20 years to major maintenance.</p> <p>Specialist advice will be sought from the paint system manufacturers at the detail design stage and the further consideration will be given to use of combined metal spray system (zinc or aluminium).</p> <p>The paint system that is likely to be considered will comprise the typical Type II paint system as shown below:</p> <ul style="list-style-type: none"> - 1st Coat: Zinc Phosphate Epoxy (two-pack) - Min dry film thickness 25 µm - 2nd Coat: High Build Glass Flake Epoxy (two-pack) - Min dry film thickness 400 µm - 3rd Coat: choice of Epoxy Acrylic Finish (two-pack), Polyurethane (two-pack), Organic Modified Polysiloxane (two-pack) - Min dry film thickness 50 or 100 µm - 4th Coat: N/A <p>Paint colour to be agreed before construction.</p>

Cover to reinforcement and concrete class shall be as required by BS 8500 and Series 1700 of the Specification for Highway Works for the exposure conditions and buried concrete classification appropriate to the site and specific elements of the structure. The exposure criteria of the concrete for design purposes will be as shown in Table 5 below:

Table 5 - Concrete exposure criteria

Element	Exposure Class	Cover		
		Minimum cover (mm)	Fixing tolerance (mm)	Nominal cover (mm)
Pile caps	XS2	70	15	85
Abutments	XS3	70	10	80
Bridge deck top surface, soffit and pier diaphragms	XS1	40	10	50
Parapet edge detail, top, sides and soffit	XS3	70	10	80
Retaining wall and their footings	XS3	70	15	85

Rev P02

Rev P02

3.11 Risks and hazards considered for design, execution, maintenance and demolition. Consultation with and/or agreement from CDM co-ordinator

A Designer's Risk Assessment will be maintained for the duration of the design process with the aim of mitigating construction, operation, maintenance and demolition hazards. Where it is not reasonably practicable to design out hazards, and these are outside the reasonable knowledge of a competent contractor, then these will be communicated to the contractor by means of residual risk register on the construction drawings.

For a detailed breakdown of the risks and hazards considered, refer to the Designer's Risk Assessment for Longbird Bridge in Appendix 3.

3.12 Estimated cost of proposed structure together with other structural forms considered (including where appropriate proprietary manufactured structure), and the reasons for their rejection (including comparative whole life costs with dates of estimates)

A detailed feasibility study to review other structural forms and full cost estimate of the proposed structure has been prepared as part of Phase II. For further details refer to Doc Ref. 3502-RAM-XX-XX-RP-CB-20001 – Rev 2 (Replacement of Swing Bridge and Longbird Bridge, Bermuda, Phase II Feasibility Report).

3.13 Proposed arrangements for construction

3.13.1 Construction of structure

The proposed bridge construction sequence is illustrated on drawing 3502-RAM-LB-XX-DR-CB-30011 in Appendix 4 and described in more detail in the following paragraphs.

The existing Longbird Bridge superstructure and substructure must be demolished prior to the construction of the new Longbird Bridge. Following demolition; preliminary excavations should take place at the foundation locations to ensure level bed profile for the subsequent pile caps.

The tubular piles for the abutment will be driven to the depth required by the design and sheet pile cofferdams installed around the proposed abutments and extent of the wingwalls. The sheet piles will be driven to the appropriate depth for both the temporary and permanent design conditions. The sea bed within the cofferdam may need to be further excavated to form a level surface where necessary, prior to pouring the plug and dewatering the cofferdam. The pilecaps and abutments can then be constructed. A waterproof membrane shall be applied to the wall faces retaining the soil fill and a drainage layer installed behind the abutment surrounded by free draining granular material. The abutments and wing walls will then be backfilled to the road formation level. The cofferdam sheet piles, which form part of the permanent works should be cut to 0.5m below the lowest astronomical tide (LAT) water level.

Provided bathymetric survey demonstrates that the water depths at the south-eastern entrance to Castle Harbour are sufficiently deep and wide to accommodate a barge of sufficient size; then the following preferred installation method for Longbird Bridge will be utilised.

Rev P02

Rev P02

Rev P02

In this method the bridge steelwork would be fabricated in its entirety, and the completed bridge shipped to Bermuda. Here, it would be transferred to a barge on which it would be floated across Castle Harbour approaching the bridge site from the east and then lowered into position, in a single operation, using a combination of the tide and barge mounted hydraulic jacks. Temporary props will be provided between the top and bottom chords of the arch at the hydraulic jack positions. The steelwork will be supported temporarily at each abutment, adjusted to achieve the correct line and level and when complete, the permanent bridge bearings will be installed, the temporary supports removed and the reinforced concrete deck slab cast.

However, should bathymetric survey indicate that the above, preferred, method is not feasible then the following alternative erection methodology will be adopted, as indicated on the construction sequence drawing 3502-RAM-LB-XX-DR-CB-30011 in Appendix 4.

The superstructure will be erected in three principle sections; a North and South bifurcation section plus a separate mid-section. It is envisaged that the North and South bifurcation sections would both have temporary top chord props to stabilise the hangers and keep the chords at the correct elevation during construction. Before erecting the superstructure, temporary piers will be constructed in appropriate locations to provide support points for the placement of each bifurcation section. Each segment could be positioned onto the supports using self-propelled modular transportation (SPMT) units from a barge or craned in. The North and South bifurcation sections will be seated directly onto the bridge abutment bearings and onto the temporary piers and temporarily restrained longitudinally.

The mid-section top chord closure piece could be erected next, either by crane or alternatively, by a system of strand jacks temporarily mounted on the already erected bifurcation sections, prior to connection to the bifurcation sections with full-strength butt welds. The mid-section bottom chord/deck closure piece can then be erected in a similar manner. If an alternative crane installation is preferred, then it may be necessary to reverse the installation sequence. The remaining mid span arch hangers will then be connected with butt welds to the top and bottom chord. Once complete, the temporary longitudinal restraints can then be removed and the reinforced concrete deck slab cast. Finally, the bridge deck will be waterproofed, and the finishes installed.

Rev P02

3.13.2 Traffic management

Traffic will continue to use the existing temporary Bailey bridges during construction of the Longbird Bridge Replacement. Hence no specific traffic management measures will be required during construction.

3.13.3 Service diversions

No services on existing bridge, hence no diversions required.

3.13.4 Interface with existing structures

The existing Longbird Bridge is to be demolished prior to commencement of construction of its replacement. The replacement bridge has been designed to span over the footprint of the existing bridge's foundations to negate the potential for clashes during construction.

4. DESIGN CRITERIA

4.1 Actions

4.1.1 Permanent actions

Self-weight of the superstructure; Permanent actions shall be in accordance with the relevant parts of BS EN 1991 and the UK National Annex

Steel will have a density of 7850kg/m³

Reinforced Concrete will have a density of 2500kg/m³

Wet Concrete will have a density of 2600kg/m³

4.1.2 Snow, Wind and Thermal actions

Wind loads will be calculated in accordance with BS EN 1991-1-4:2005 and the UK National Annex. Wind loading will be considered using a fundamental design wind speed of 150 mph in accordance with the Bermuda Building Code 2014.

Rev P02 | Assessment on the aerodynamic stability of the structure will be performed in accordance with BS EN 1991-1-4 as supplemented by PD 6688-1-4.

Rev P02 | Thermal loads will be calculated in accordance with BS EN 1991-1-5:2003 along with the UK National Annex and will be based on the shade air temperature range of 5°C to 34°C. In line with the provisions of NA.2.21 of NA to BS EN 1991-1-5 and taking into account the ambient temperature range of Bermuda, the construction temperature T_0 will be taken as 15 degrees Celsius for expansion and 25 degrees Celsius for contraction. Uniform temperature will be assumed along the entire length of the structure.

Rev P02 | Differences in the uniform temperature component between different structural elements will be considered in accordance with clause 6.1.6 of BS EN 1991-1-5:2003 along with the UK National Annex. In particular, a 15 degree Celsius differential will be considered between the main structural elements (arch top chord, arch bottom chord/deck and hangers).

Rev P02 | For temperature gradient the superstructure will be considered as Type 2.

No snow loading will be considered.

4.1.3 Actions relating to normal traffic under AW regulations and C&U regulations

The structure has been designed to the BS EN 1991-2 as modified by UK National Annex for highways traffic 'Load Model 1', which includes a Uniformly Distributed Load of 5.5 kN/m² along with double-axle concentrated loads (tandem systems) per notional lane acting on the most unfavourable part of the influence surface, as indicated in Figure 1 below.

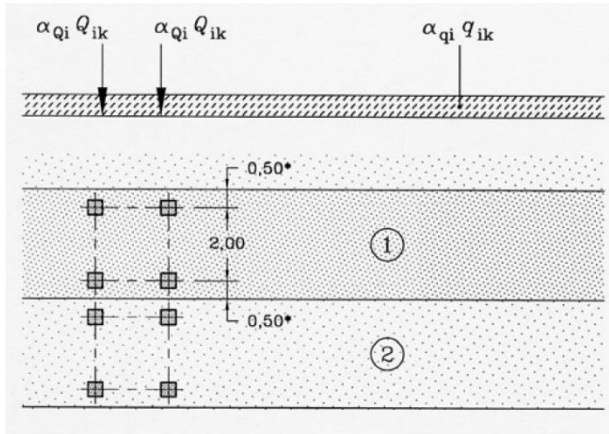

Load Model 1 based on BS EN 1991-2

Key:

Carriageway - Lane 1: $Q_{1k} = 300 \text{ kN}$ $q_{1k} = 5.5 \text{ kN/m}^2$

Carriageway - Lane 2: $Q_{2k} = 200 \text{ kN}$ $q_{2k} = 5.5 \text{ kN/m}^2$

Remaining area of carriageway: $q_k = 5.5 \text{ kN/m}^2$

Tandem axle spacing = 1.2 m

Lane width = 3.0 m

Figure 1 - Representation of Load Model 1

Rev P02

By way of comparison Figure 2 and Figure 3 below indicate the assessment live loading for the assessment (or evaluation) of existing bridge structures in Bermuda derived by the Delcan Corporation in their report 'Evaluation Criteria for Highway Bridges in Bermuda' produced for the Ministry of Public Works. The loading arrangements depicted in Figure 2 and Figure 3 are based upon actual vehicles typical to Bermuda.

Rev P02

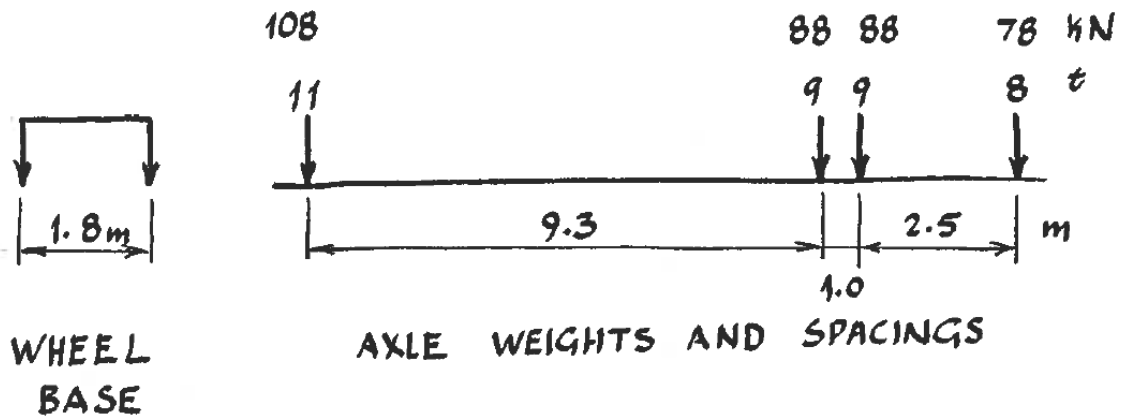

Figure 2 - Proposed Evaluation Truck for Bermuda

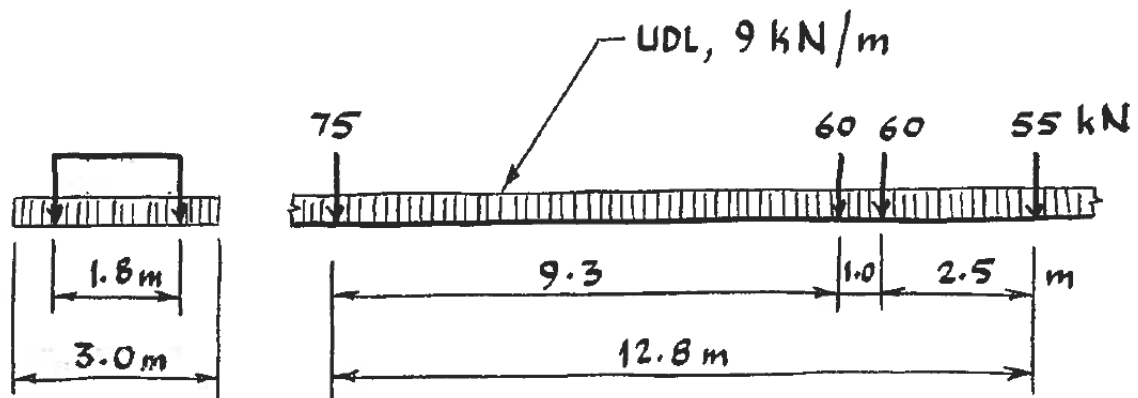

Figure 3 - Proposed Evaluation Lane Load for Bermuda

Whilst the Load Model 1 and the Evaluation loading are not quite the same in that they are not both patterns of design live load, it can be seen by inspection that the Load Model 1 case is more onerous.

It should be noted that in the Delcan report the partial factor for live loads is proposed as 1.6 at ULS. Whereas in BS EN the equivalent load factor is 1.35. However even after taking this difference into consideration it can be seen by inspection that it remains that the BS EN Load Model 1 loads are more onerous and are appropriate for detailed design in Phase III.

4.1.4 Actions relating to General Order traffic under STGO regulations

N/A

4.1.5 Footway or footbridge variable actions

The structure will be designed for a vertical uniformly distributed live load of 5kN/m². For the footway, where the vehicle access is prevented by the VRS, a point load of 10kN will be considered acting on a 100mm x 100mm in accordance with BS EN 1991-2:2003 Cl 5.3.2.2(1).

4.1.6 Actions relating to Special Order traffic, provision for exceptional abnormal indivisible loads including location of vehicle track on deck cross-section

N/A

4.1.7 Accidental actions

Vehicle impact

On Longbird bridge the primary structural elements are above the deck and although they are protected by the high containment kerb and VRS there is potential risk of vehicle losing control and striking a structural element. To address such a risk the arch ribs will be designed to sustain

an impact force from the vehicle. The structure will also be designed to sustain a sudden loss of a hanger in accordance with clause 2.3.6 of BS EN 1993-1-11.

Vessel Impact

Ship impact into the superstructure and substructure has been considered.

As a fixed bridge span, navigation through Longbird Replacement is only possible for motorboats with low enough air draft to pass under the bridge. If a motorboat loses steerage or the skipper miscalculates, then the boat deckhouse or mast could impact the superstructure.

The design hull substructure impact load from the 50ft motorboat design vessel was calculated to be 840kN in accordance with AASHTO (1991). For further details of the design vessel and derivation of the associated vessel impact loads please refer to section 4.9 of the Phase II Feasibility Report (document number 3502-RAM-XX-XX-RP-CB-20001 rev. 02).

The substructure load will not be applied to the bridge as the substructure is out of the waterway and therefore vessel collision is not an issue. However, as per AASHTO, the vessel deckhouse load is estimated to be 20% of the substructure load, and the vessel mast impact load is estimated to be 10% of the deckhouse load.

Table 6 - Vessel Impact Summary

Impact Case	Impact load	Location
Head on impact of motor boat hull on bridge substructure	840kN	Not applied.
Glancing impact of motor boat hull on bridge substructure	420kN Applied separately to head on impact case.	Not applied.
Impact of motor boat deckhouses on bridge superstructure	168kN	Action applies from MHW + 1.5m to MHW + 3.5m*, in a direction parallel to the main channel axis.
Impact of motor boat mast on bridge superstructure	17kN	Action applies from MHW + 3.5m to MHW + 4m*, in a direction parallel to the main channel axis.

*These values are estimated based on a 4m air draft

Given the information on water levels and surge levels in relation to the proposed +4.2mOD soffit level, it is predicted that the worst collision case would be a deckhouse collision on the bridge superstructure. The structure shall be designed to be robust enough to withstand this force on the bridge deck.

Vessel Impact Protection

Rubbing strakes of durable timber or plastic will be provided along the sides of the bridge abutments to protect the structural elements from damage by minor glancing impacts.

Accidental vessel impact creates a risk to life, or injury, both to bridge users and to vessel users. During an impact, the vessels bow and/or deckhouse might be crushed, or the mast and rigging may collapse. The design of the bridge will aim to mitigate these risks. For example, the Longbird Bridge Replacement abutments have been profiled in plan to increase the likelihood that vessels will be deflected into the channel rather than suffer head on impact. Aids to navigation will also be provided to further reduce the risk of a collision.

Wind/wave loading

The wave loading on the superstructure has been considered at the feasibility stage in accordance with section 4.9.11 of the Phase II Feasibility Report. The connections between the substructure and superstructure, will be provided to ensure that the bridge decks remain in place during the hurricane event. The hydrodynamic loading on the pier and abutments has been considered in accordance with section 4.9.12 of the Phase II Feasibility Report as replicated below.

Wave loads on bridge deck

Guidance from AASHTO BVCS (Bridges Vulnerable to Coastal Storms 2008) is based on bridge geometries of the girder type shown below in Figure 4 and Figure 5. The curved shell type geometry of the proposed Longbird Bridge Replacement have been idealised to represent the AASHTO girder type cross sections to be in-line with the code

Rev P02

According to AASHTO BVCS (2008), two different design cases must be analysed to evaluate the forces applied on the bridge deck by the waves. The forces on the piers, abutments, and other retaining walls are addressed separately. The design cases for wave action on the bridge deck are:

- Design Case I: Maximum quasi-static vertical force and associated horizontal force, moment, and vertical slamming forces
- Design Case II: Maximum horizontal wave force and associated quasi-static vertical force, moment and vertical slamming force

According to AASHTO BVCS (2008), the wave force equations were developed around the trailing edge of the girders as shown in Figure 4 and Figure 5, and calculations of force effects on the structure shall start with the forces assumed to be applied at the trailing edge. The forces shall be applied to the full length of one span of the structure at the same time. Although the slamming force is instantaneous, to design against bridge uplift the maximum quasi-static vertical force and the slamming force must be combined.

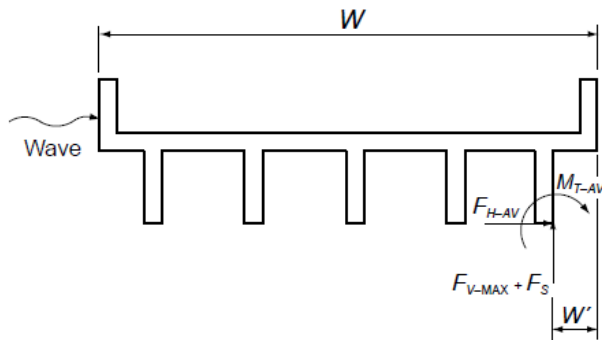

(a) Case I— F_{V-MAX} with Associated Forces

Figure 4 - Diagrams extracted from AASHTO BVCS (2008) illustrating the applied maximum vertical force and associated horizontal force, slamming force, and moment, applied along the length of the span or bridge

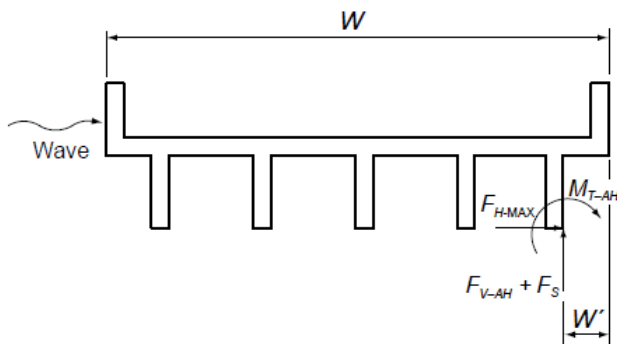

(b) Case II— F_{H-MAX} with Associated Forces

Figure 5 - Diagrams extracted from AASHTO BVCS (2008) illustrating the applied maximum horizontal force and associated vertical force, slamming force, and moment, applied along the length of the span or bridge

Rev P02

Figure 6 illustrates in sketch form the interaction of the wave with a typical bridge structure.

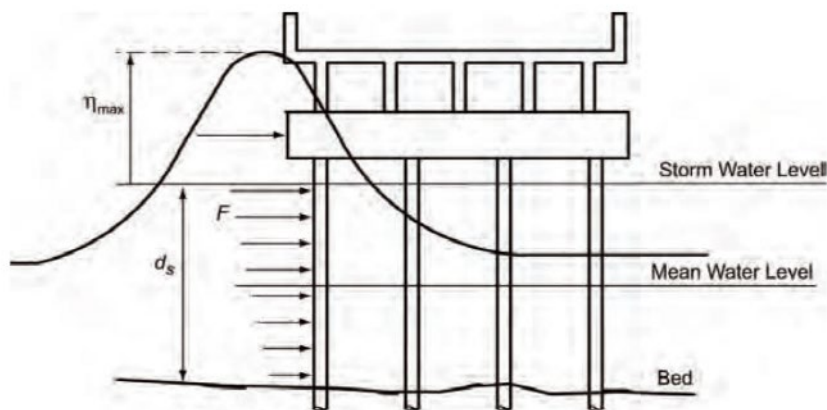

Figure 6 - Extract from AASHTO BVCS (2008) Illustrating the Interaction of Waves with the Bridge Structure

Longbird Bridge Parameters

The following parameters have been used to derive wave forces on Longbird Bridge. The water depth at both bridges has been taken as the deepest based on the review of bathymetric information available.

Rev P02

S_L	Bridge Soffit Level above OD	4.20	m	13.78	ft
H_{max^*}	Max wave height (limited)	5.58	m	18.29	ft
H_{max}	Max wave height	5.99		19.65	ft
T_p	Peak wave period	5.00	s	5.00	s
λ or L	Wave length	39.03	m	128.06	ft
d	Water depth below OD	6.00	m	19.69	ft
SLR	Relative sea level rise above water level by 2100	0.86	m	2.82	ft
$Surge$	1:150yr predicted surge level, mOD	2.20	mOD	7.22	ftOD
d_s	Storm water level (by 2100) above seabed	9.06	m	29.72	ft
η_{max}	Distance from the storm water level to design water crest	3.90	m	12.81	ft
	Non-linear wave assymetry factor	0.70			
r	Rail height	0.65	m	2.13	ft
γ_w	unit weight of water taken as 0.064 kip/ft ³			0.06	kip/ft ³
W	Bridge width	11.65	m	38.22	ft
Z_c	Vertical distance from the bottom of the cross section to d_s	1.14	m	3.74	ft
d_b	Depth of bridge deck	1.55	m	5.09	ft
d/L (present)		0.15			
d/L (by 2100)		0.23			
$0.65 d_s$		5.89			
$\lambda / 7$		5.58			

Results of wave forces on bridge decks with Sea Level Rise (SLR) taken as 0.86m

The wave forces on the bridge decks are presented as follows:

Table 7 - Summary Wave Forces Case I

	Design Case I
	Longbird Bridge Replacement
F_{V-MAX} (kN/m)	147.5
F_{H-AV} (kN/m)	74.2
F_S (kN/m)	75.6
M_{T-AV} (kNm/m)	1828.2

Rev P02

For the Design of the bridge deck the actions in Table 7 above will be applied to the soffit at $W/2$ ($=5.825m$) from the centreline as illustrated in Figure 4.

Table 8 - Summary of Wave Forces Case II

	Design Case II
	Longbird Bridge Replacement
F_{H-MAX} (kN/m)	92.3
F_{V-AH} (kN/m)	129.8
F_S (kN/m)	75.6
M_{T-AH} (kNm/m)	1253.8

Rev P02

For the Design of the bridge deck the actions in Table 8 above will be applied to the soffit at $W/2$ ($=5.825m$) from the centreline as illustrated in Figure 5.

Wind load coexisting with Case II wave loading will not be applied to the deck below top of parapet level as this zone is loaded by wave action.

Results of wave forces on bridge decks with SLR taken as 0m

Table 9 - Summary of Wave Forces Case I

	Design Case I
	Longbird Bridge Replacement
F_{V-MAX} (kN/m)	59.9
F_{H-AV} (kN/m)	61.4
F_S (kN/m)	47.0
M_{T-AV} (kNm/m)	912.7

Rev P02

Rev P02

For the Design of the bridge deck the actions in Table 9 above will be applied to the soffit at $W/2$ ($=5.825m$) from the centreline as illustrated in Figure 4.

Table 10 - Summary of Wave Forces Case II

	Design Case II
	Longbird Bridge Replacement
F_{H-MAX} (kN/m)	87.0
F_{V-AH} (kN/m)	75.1
F_S (kN/m)	47.0
M_{T-AH} (kNm/m)	1115.7

Rev P02

Rev P02

For the Design of the bridge deck the actions in Table 10 above will be applied to the soffit at $W/2$ ($=5.825m$) from the centreline as illustrated in Figure 5.

Wind load coexisting with Case II wave loading will not be applied to the deck below top of parapet level as this zone is loaded by wave action.

Reducing the SLR value to 0m, has a significant impact. For Longbird Bridge, it not only reduces the storm water level but also reduces the design wave height as it is limited by the water depth.

Rev P02

Overtopping Case

The design surge wave crest is above the bridge deck level; hence, an overtopping case will be considered. The bridge will be designed for a loading of 70kN/m applied along the length of the deck between inner faces of arch bottom chords. This will represent the loading from the static weight of water accumulated on the deck once the surge wave crest has passed.

Hydrodynamic loads on wide piers, and walls

Waves encountering vertical, wide structures will behave differently as the full depth of the wave will hit the structure, and the water will be projected upwards above wave crest level. Clause 6.1.3 of AASHTO BVCS (2008) provides guidance on the calculation of hydrodynamic loads on bridge substructures based on Goda's method.

Rev P02

Figure 7 summarises the wave pressure profile to be applied using the Goda method on such piers and walls.

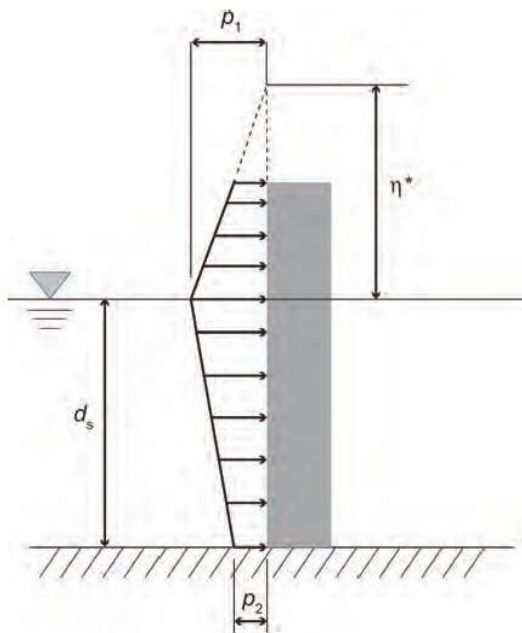

Figure 7 - Extract from AASHTO BVCS (2008) Showing Wave Force Profiles on Large Elements

Results of Wave Forces on Substructure with SLR taken as 0.86m

Rev P02

The results obtained for Longbird Bridge Replacement are presented as follows:

Table 11 - Summary of Wave Loads on Abutments and Walls – SLR=0.86m

	Longbird Bridge Replacement
p1 (kN/m ²)	36.4
P2 (kN/m ²)	16.1
η* (m)	8.4
d _s (m)	9.1

Rev P02

When considering SLR=0.86m the value of peak pressure p₁, its application level of +3.10m OD and the dimension η* are common for all abutments/walls. Pressure P₂ and the dimension from storm water level to bed level, d_s, shown in Table 11 are based upon an assumed bed level of -6.00m OD. For abutments/walls with bed depths other than -6.00m OD, p₂ is to be determined by linear interpolation from the p₁ and p₂ values from Table 11 using the dimension d_s applicable for the bed depth at the location under consideration.

Results of Wave Forces on Substructure with SLR taken as 0m

Rev P02

The results obtained for Longbird Bridge Replacement are presented as follows:

Table 12 - Summary of Wave Loads on Abutments and Walls – SLR=0.0m

	Longbird Bridge Replacement
p1 (kN/m ²)	36.0
P2 (kN/m ²)	18.0
η* (m)	8.0
d _s (m)	8.2

Rev P02

When considering SLR=0.0m the value of peak pressure p₁, its application level of +2.20m OD and the dimension η* are common for all abutments/walls. Pressure P₂ and the dimension from storm water level to bed level, d_s, shown in Table 12 are based upon an assumed bed level of -6.00m O D. For abutments/walls with bed depths other than -6.00m OD, p₂ is to be determined by linear interpolation from the p₁ and p₂ values from Table 12 using the dimension d_s applicable for the bed depth at the location under consideration.

Wave Loading Calculation Approach

Rev P02

According to AASHTO BVCS (2008) bridges classed as critical/essential should be designed at the strength limit state to achieve a state of “service immediate”. Bridges considered secondary to rescue and recovery may be designed at the extreme event limit state. Under the strength limit state, a load factor of 1.75 is applied to the wave loads whereas the load factor is unity for the extreme limit state. These load factors are based on the design event being a 1 in 100yr event whereas the analysis carried out herein has been based on a 1 in 150yr event as agreed with the Client and therefore the load factors can be considered conservative for such an event.

The combined total SLR of 0.86m (0.76m for sea level rise and 0.1m for land subsidence) in conjunction with the 1 in 150yr hurricane event provides a conservative worst-case scenario.

Rev P02

Including this scenario under the strength limit state with the associated factor of 1.75 was considered an overly conservative approach, therefore a method has been adopted whereby three separate scenarios will be considered as follows:

1. Wave loads with SLR considered as 0.86m - Extreme Event Limit State [factor of 1.0] – wave loads on deck and abutments/walls will be considered as coincident.
2. Wave loads with SLR considered to be 0m – Strength Limit State [factor of 1.75] – wave loads on deck and abutments/walls will be considered as coincident.
3. Overtopping case with SLR considered as 0.86m – Extreme Event Limit State [factor of 1.0] – overtopping loading as noted above to be applied to the bridge deck - no wave loads considered on the deck and abutments/walls.

Seismic loading

Bermuda is known to be situated in an area that is seismically active. The Bermuda Building Code 2014 cl. 1610.1 states that "Consideration of earthquake loads should be taken into account especially when designing multi storey, non-symmetrical eccentrically loaded structures or those containing sensitive equipment.

As part of the Feasibility Study for the crossing of Castle Harbour and Grotto Bay, Halcrow undertook a specialist seismic hazard study to confirm the seismic loading appropriate for Bermuda (refer to report 'Government of Bermuda, MW&E&H, New Crossing, Waters of Castle Harbour / Grotto Bay, Bermuda – Seismic Hazard Study, April 2010).

Site specific uniform hazard spectra for the horizontal component of the ground motion are proposed in this report for return periods of 500 years, 1000 years and 2500 years and for rock site conditions.

The 500-year return period uniform hazard spectrum for rock site conditions will be used as a reference for design, implementing the seismic design provisions of BS EN 1998-1, BS EN 1998-2 and BS EN 1998-5 as appropriate. This return period is approximately equal with the recommended value of the reference return period of Eurocode being 475 years. This return period corresponds to seismic loading with probability of exceedance of 10% in 50 years.

To achieve a level of seismic loading with the same level of probability of exceedance for the 75 years design life of the bridge reference is made to Annex A of BS EN 1998-2.

The return period of the seismic loading which corresponds to $p=10\%$ in $t_L = 75$ years (design life of bridge) is given by equation A.1 of Annex A of BS EN 1998-2 as below:

$$T_R = 1/(1-(1-p)^{1/t_L}) = 1/(1-(1-0.1)^{1/75}) = 712 \text{ years}$$

An acceptable estimation for the spectral acceleration ratio that corresponds to the return period T_R in relation to the reference period T_{NCR} is given by equation A.3 of Annex A of BS EN 1998-2 as below:

$$a(T_R) / a(T_{NCR}) = (T_R / T_{NCR})^k = (712/500)^{0.35} = 1.132$$

Rev P02

The bridge is considered to be of importance class II in accordance with Clause 2.1 (4)P of BS EN 1998-2 therefore the importance factor for the above case is taken as $\gamma_I = 1.00$.

The spectral accelerations of the reference return period and the return periods of the seismic loading are tabulated below.

Table 13 - Spectral accelerations

Rock Soil Conditions	Reference return period $T_{NCR} = 500$ years	Return period for 10% probability of exceedance in 75 years $T_R = 712$ years
Period (sec)	Reference Spectral Acceleration * g (m/sec ²)	Design Spectral Acceleration * g (m/sec ²)
0 (PGA)	0.06	$0.06 * 1.132 = 0.068$
0.1	0.10	$0.10 * 1.132 = 0.113$
0.2	0.08	$0.08 * 1.132 = 0.091$
0.4	0.06	$0.06 * 1.132 = 0.068$
1.0	0.02	$0.02 * 1.132 = 0.023$
2.0	0.01	$0.01 * 1.132 = 0.011$

The soil amplification factors from Table 3.3 of BS EN 1998-1 will be used for design depending on the founding ground type.

4.1.8 Action during construction

Actions during execution has been considered in accordance with BS EN 1991-1-6:2005. The structure will be designed taking due consideration of the different support conditions during transportation and erection.

4.1.9 Any special action not covered above

Superimposed Dead Load

Load factors for bridge deck surfacing shall be $\gamma_{fl\ SLS} = 1.00 * 1.55 = 1.55$ and be $\gamma_{fl\ ULS} = 1.20 * 1.55 = 1.86$ (Table NA.A2.4(B) of UK NA to BS EN 1990 and Table NA.1 of UK NA to BS EN 1991-1-1). This allows for the potential increase in self-weight of surfacing over the bridge caused by maintenance operations by the Government of Bermuda resulting in the increased thickness of total surfacing material e.g. from overlay/surfacing dressing.

Scour

Rev P04

Scour and hydraulic actions on the bridge piers and abutments shall be considered via an assessment of scour risk for the proposed bridge foundations using the HEC-18 method. Appropriate scour mitigation measures will be designed as appropriate and if required.

Rev P04

The flow/tidal velocity appropriate to assess scour and design for mitigation measures is 0.92m/s based on maximum modelled tidal currents from the proposed Longbird Bridge taken from Waters of Castle Harbour and Grotto Bay, Halcrow, 2010. Scour from wave action will be considered. Scour from Vessels travelling at 5 knots has been ruled out due to water depth at LAT.

Vehicle Restraint System (VRS)

A vehicle restraint system (VRS) will be installed on Longbird Bridge. It is proposed the VRS will be a tubular CHS positioned with its centroid 600mm above the adjacent carriageway and set back a minimum of 600mm from the traffic face. Additional protection will be provided by high containment kerbs on each side of the carriageway.

A risk assessment for the Road Restraint System requirement will be prepared and this will confirm the VRS design approach.

Rev P02

Assuming the VRS comply with BS EN 1317-2; with the performance class B (normal containment rigid parapet connections between restraint and kerb or bridge; as per Table 4.9(n), BS EN 1991-2:2003 - Section 4.7.3.3) to determine the equivalent average impact force assuming normal containment level N1 (appropriate for low speed permanent installations) and with 0.1m deflection, the average force is 200kN. This is based on 80kph collision at 20° (Tables 1&2, BS EN 1317-2:2010).

To determine an equivalent load for the situation of a road with the design speed of 50kph, the average force is multiplied by $50^2/80^2$ (i.e. the ratio of the velocities squared as the calculated force is proportional to velocity squared) which gives an equivalent force of 78.1kN.

Fatigue Loading

In accordance with Table NA.4 of UK NA to BS EN 1991-2 the fatigue loading for the bridge shall be based on the travelled lane configuration; i.e. 2No. travelled lanes at 3.5m wide and shall comprise 0.5×10^6 ($=N_{obs}$) heavy goods vehicles per slow lane per year as for an all-purpose single carriageway.

The number N_{obs} represents heavy vehicles (maximum gross vehicle weight more than 100 kN), observed or estimated, per year and per slow lane (i.e. a traffic lane used predominantly by lorries).

Fatigue Load Model 3 (single vehicle model) in accordance with Clause 4.6.4 of BS EN 1991-2 will be used for the fatigue assessment from the traffic loads. This vehicle comprises 4 No. axles of 120 kN each resulting to a total vehicle load of 480kN.

Steel elements will be assessed for safe life using the detail categories from Tables 8.1 to 8.10 of BS EN 1993-1-9:2005 and the fatigue loading described above. A value of $\gamma_{Mf} = 1.1$ will be adopted according to clause NA.2.5.3 of NA to BS EN 1993-1-9:2005.

Wind Induced Fatigue in Hangers

Rev P03

The requirement to design for fatigue under various sources of loading, including environmental loads such as wind, is inherent in the Eurocodes BS EN 1993-1-9, associated NA and PD 6695

Rev P03

outlining the recommendations for the design of structures to this standard. As part of the detailed design process we will calculate the fundamental frequency of the hangers to determine the ratio between the first bending (translational) frequency and first torsional frequency, including a sensitivity check to take account of the likely range of tension within the hanger.

The results of the above will be used to determine the susceptibility of each hanger to divergence or flutter in accordance with clause A.4.2 of PD 6688-1-4:2015. No further specific wind induced fatigue check will be necessary for the hangers demonstrated not to be prone to divergence or flutter.

Loading for Abutment Inspection Galleries and Associated Accessways

Access-ways to and within the plant rooms shall be designed for the imposed loading requirements BS EN ISO 14122-1:2016 'Safety of machinery – permanent means of access to machinery. Choice of fixed means and general requirements of access' appropriate for General Duty access. (UDL 5.0 kN/m²; Concentrated Load 1.0kN) $\gamma_{FL} = 1.0$ shall be used at the serviceability limit state (SLS) and $\gamma_{FL} = 1.5$ at the ultimate limit state (ULS) for all load combinations.

Loading within the Deck Steelwork Box for Inspection and Maintenance

Deck soffit plates shall be designed to accommodate live loading within the box structures for inspection and maintenance access. The live loading shall comprise a UDL of 1.5 kN/m² over a total area of 10m² of any shape, which may be continuous or divided to give the most adverse effect, together with a UDL of 0.75 kN/m² elsewhere. $\gamma_{FL} = 1.0$ shall be used at the serviceability limit state (SLS) and $\gamma_{FL} = 1.5$ at the ultimate limit state (ULS) for all load combinations.

4.2 Heavy or high load route requirements and arrangements being made to preserve the route, including any provision for future heavier loads or future widening

Not applicable

4.3 Headroom provided

The main bridge structure bridge will be designed with a mid-span headroom clearance of 3.67m above highest astronomical tide.

Rev P02

4.4 Authorities consulted and any special conditions required

Consultations with Statutory Undertakers are underway.

A full existing services site survey is to be performed by the Client and summarised in a combined services drawing to verify the location of each of the services and confirm which are live and which are redundant in order to inform a strategy for diversion and protection of services prior to construction and demolition works.

4.5 Standards and documents listed in the Technical Approval Schedule

See Appendix 1.

Rev P02

In addition, reinforcement to control early thermal cracking of reinforced elements will be designed in accordance with the requirements of CIRIA document, C766 – *Control of cracking caused by restrained deformation in concrete*. This document supersedes the previous CIRIA document C 660 relating to this subject. CIRIA C 660 is referred to in the Published Documents (PDs) to BS EN 1992-2 (PD 6687-2 cl. 8.2.3) and BS EN 1992-1-1 (PD 6687-1 cl. 2.21.3) and counts in Eurocode terminology as "NCCI" (Non Contradictory Complimentary Information). It is considered that CIRIA C 766 is a direct update of NCCI and therefore should be used immediately for new projects, and on this basis it is proposed for Longbird Bridge Replacement.

4.6 Proposed Departures relating to departures from standards given in 4.5

None

4.7 Proposed Departures relating to methods for dealing with aspects not covered by standards in 4.5

None

5. STRUCTURAL ANALYSIS

5.1 Methods of analysis proposed for superstructure, substructure and foundations

Superstructure

The superstructure will be analysed as a three-dimensional model using the linear elastic analysis computer program LUSAS. Both thick shell elements and beam elements as appropriate will be assigned to different parts of the structure to form the three dimensional model.

If required, dynamic mode shapes and frequencies will also be determined from a three-dimensional model using LUSAS.

The substructure and pile caps will be analysed using standard elastic methods and hand calculations.

Pile loads will be determined using the method of A.J.Francis ref ASCE Journal "Analysis of pile groups with flexural resistance" and expanded by Sawko in a paper in the Structural Engineer "A simplified approach to the analysis of piling systems."

5.2 Description and diagram of idealised structure to be used for analysis

See Appendix 2.

5.3 Assumptions intended for calculation of structural element stiffness

The stiffness of the steel elements will be based on the gross section properties and steel elastic moduli $E=210\text{GPa}$. The transverse diaphragms will be designed to act compositely with the reinforced concrete deck slab.

The stiffness of the substructure concrete elements and piles will be based on elastic uncracked section properties.

5.4 Proposed range of soil parameters to be used in the design of earth retaining elements

The earth retaining elements identified are the abutments and the retaining walls.

The design of earth retaining elements will be in accordance with PD 6694-1:2011. The backfill material will be assumed as a free draining granular material with properties and grading conforming to Classes 6N or 6P, specified, installed and compacted in accordance with the Highway's Agency's Manual of Contract Documents for Highway Works (MCHW).

The surcharge loading behind the walls will be in accordance with Clause 7.6 of PD 6694-1:2011 for loading from normal traffic.

6. GEOTECHNICAL CONDITIONS

6.1 Acceptance of recommendations of the Geotechnical Design Report to be used in the design and reasons for any proposed changes

Rev P02

The Ground Investigation Report (GIR report no. 3502-RAM-XX-XX-RP-CE-30001) is now complete. Geotechnical parameters for use in the design of Longbird Bridge Replacement are provided in the Geotechnical Report – Highway Structure Summary Information 'Form C' in Appendix 5.

6.2 Summary of design for highway structure in the Geotechnical Design Report

Rev P02

The Ground Investigation Report (GIR report no. 3502-RAM-XX-XX-RP-CE-30001) is now complete. Geotechnical parameters for use in the design of Longbird Bridge Replacement are provided in the Geotechnical Report – Highway Structure Summary Information 'Form C' in Appendix 5.

6.3 Differential settlement to be allowed for in the design of the structure

Rev P02

Differential settlement to be allowed in the design of the structure will be 10mm.

6.4 If the Geotechnical Report is not yet available, state when the results are expected and list the sources of information used to justify the preliminary choice of foundations.

Rev P02

The Ground Investigation Report (GIR report no. 3502-RAM-XX-XX-RP-CE-30001) is now complete. Geotechnical parameters for use in the design of Longbird Bridge Replacement are provided in the Geotechnical Report – Highway Structure Summary Information 'Form C' in Appendix 5.

7. CHECK

7.1 Proposed Category and Design Supervision Level

Category 3, DSL3.

7.2 If Category 3, name of proposed Independent Checker

Government of Bermuda to appoint Category 3 checker.

7.3 Erection proposals or temporary works for which Types S and P Proposals will be required, listing structural parts of the permanent structure affected with reasons

Not applicable

8. DRAWINGS AND DOCUMENTS

8.1 List of drawings (including numbers) and documents accompanying the submission

The following Approval in Principle drawings are included in Appendix 4:

3502-RAM-LB-XX-DR-CB-30001 Rev. P01 - Longbird Bridge Replacement, Approval in Principle, General Arrangement, Sheet 1 of 4

3502-RAM-LB-XX-DR-CB-30002 Rev. P01 - Longbird Bridge Replacement, Approval in Principle, General Arrangement, Sheet 2 of 4

Rev P02

3502-RAM-LB-XX-DR-CB-30003 Rev. P02 - Longbird Bridge Replacement, Approval in Principle, General Arrangement, Sheet 3 of 4

Rev P02

3502-RAM-LB-XX-DR-CB-30004 Rev. P02 - Longbird Bridge Replacement, Approval in Principle, General Arrangement, Sheet 4 of 4

3502-RAM-LB-XX-DR-CB-30011 Rev. P01 - Longbird Bridge Replacement, Approval in Principle, Construction Sequence

9. THE ABOVE IS SUBMITTED FOR ACCEPTANCE

Signed



Name

Eur Ing Steve Thompson

Engineering Qualifications

BEng CEng FICE

Position Held

Director

Name of Organisation

Ramboll

Date

16-05-2019

**10. THE ABOVE IS REJECTED/AGREED SUBJECT TO THE
AMENDMENTS AND CONDITIONS SHOWN BELOW**

Signed

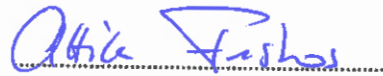

Name

Attila Fustos

Position Held

Principal Eng

Engineering Qualifications

MICE, CEng

TAA

Bermuda Government

Date

27 May 2019

APPENDIX 1 TECHNICAL APPROVAL SCHEDULE (TAS)

Technical Approval Schedule (TAS)

Schedule of Documents Relating to Design of Highway Bridges and Structures

Documents relevant to this project are indicated by a tick.

Eurocodes

All national annexes will be used with the list of documents below. Documents relevant to this project are indicated by a tick

Used	Eurocode Part	Title	Publication Date	UK National Annex Publication Date
Eurocode 0 Basis of Structural Design				
✓	BS EN 1990	Eurocode 0: Basis of structural design	Jul-02	Dec-04
Eurocode 1 Actions on Structures				
✓	BS EN 1991-1-1	Actions on structures. General actions. Densities, self- weight, imposed loads for buildings	Jul-02	Dec-05
	BS EN 1991-1-3	Actions on structures. General actions. Snow loads	Jul-03	Dec-05
✓	BS EN 1991-1-4	Actions on structures. General actions. Wind actions	Apr-05	Sep-08
✓	BS EN 1991-1-5	Actions on structures. General actions. Thermal actions	Mar-04	Apr-07
✓	BS EN 1991-1-6	Actions on structures. General actions. Actions during execution	Dec-05	May-08
✓	BS EN 1991-1-7	Actions on structures. General actions. Accidental actions	Sep-06	Dec 08
✓	BS EN 1991-2	Actions on structures. Traffic loads on bridges	Oct-03	May-08
Eurocode 2 Design of Concrete Structures				
✓	BS EN 1992-1-1	Design of concrete structures – Part 1-1: General rules and rules for buildings	Dec-04	Dec-05
✓	BS EN 1992-2	Design of concrete structures – Part 2: Concrete bridges – Design and detailing rules.	Dec-05	Dec-07
	BS EN 1992-3	Design of concrete structures – Part 3: Liquid retaining and containment structures	Jul-06	Oct-07

Used	Eurocode Part	Title	Publication Date	UK National Annex Publication Date
Eurocode 3 Design of Steel Structures				
✓	BS EN 1993-1-1	Design of steel structures – Part 1-1: General rules and rules for buildings	May-05	Dec-08
	BS EN 1993-1-3	Design of steel structures – Part 1-3: General – General rules – Supplementary rules for cold-formed members and sheeting.	Nov-06	Mar-09
✓	BS EN 1993-1-4	Design of steel structures – Part 1-4: General rules – Supplementary rules for stainless steel.	Nov-06	Mar-09
✓	BS EN 1993-1-5	Design of steel structures – Part 1-5: Plated structural elements	Nov-06	May-08
	BS EN 1993-1-6	Design of steel structures – Part 1-6: General – Strength and stability of shell structures	May-07	Mar-09
✓	BS EN 1993-1-7	Design of steel structures – Part 1-7: General – Plated structures subject to out of plane loading.	Jul-07	Mar-09
✓	BS EN 1993-1-8	Design of steel structures – Part 1-8: General – Design of joints	May-05	Dec-08
✓	BS EN 1993-1-9	Design of steel structures – Part 1-9: Fatigue	May-05	May-08
✓	BS EN 1993-1-10	Design of steel structures – Part 1-10: Material toughness and through thickness properties.	May-05	Dec-08
✓	BS EN 1993-1-11	Design of steel structures – Part 1-11: Design of structures with tension components	Nov-06	Dec-08
	BS EN 1993-1-12	Design of steel structures – Part 1-12: Additional rules for the extension of EN 1993 up to steel grades S 700.	May-07	May-08
✓	BS EN 1993-2	Design of steel structures – Part 2 Steel Bridges	Nov-06	May-08
✓	BS EN 1993-5	Design of steel structures – Part 5 Piling	Apr-07	Mar-09
Eurocode 4 Design of Composite Steel and Concrete Structures				
	BS EN 1994-1-1	Design of composite steel and concrete structures – Part 1-1: General rules and rules for buildings	Feb-05	Aug-08
✓	BS EN 1994-2	Design of composite steel and concrete structures – Part 2 General rules and rules for bridges.	Dec-05	Dec-07

Used	Eurocode Part	Title	Publication Date	UK National Annex Publication Date
Eurocode 5 Design of Timber Structures				
	BS EN 1995-1-1	Design of timber structures – Part 1-1: General – Common rules and rules for buildings	Dec-04	Oct-06
	BS EN 1995-1-2	Design of timber structures – Part 1-2: General – Structural fire design	Dec-04	Oct-06
	BS EN 1995-2	Design of timber structures – Part 2 Bridges	Dec-04	Oct-06
Eurocode 6 Design of Masonry Structures				
	BS EN 1996-1-1	Design of masonry structures – Part 1-1: General rules for reinforced and unreinforced masonry structures.	Dec-05	May-07
	BS EN 1996-1-2	Design of masonry structures – Part 1-2: General – Structural fire design	Jun-05	May-07
	BS EN 1996-2	Design of masonry structures – Part 2 Design considerations, selection of materials and execution of masonry.	Feb-06	May-07
	BS EN 1996-3	Design of masonry structures – Part 3: Simplified calculation methods for unreinforced masonry structures	Feb-06	May-07
Eurocode 7 Geotechnical design				
✓	BS EN 1997-1	Geotechnical design – Part 1 General rules	Dec-04	Nov-07
✓	BS EN 1997-2	Geotechnical design – Part 2 Ground investigation and testing	Apr-07	Mar 09
Eurocode 8 Design Of Structures For Earthquake Resistance				
	BS EN 1998-1	Design of structures for earthquake resistance – Part 1 General rules, seismic actions and rules for buildings	Apr-05	Aug-08
	BS EN 1998-2	Design of structures for earthquake resistance – Part 2 Bridges	Dec-05	Feb-09
	BS EN 1998-5	Design of structures for earthquake resistance – Part 5 Foundations, retaining structures and geotechnical aspects	Apr-05	Aug-08
Eurocode 9 Design Of Aluminium Structures				
	BS EN 1999-1-1	Design of aluminium structures – Part 1-1 General structural rules	Aug-07	Dec-08
	BS EN 1999-1-2	Design of aluminium structures – Part 1-2: General – Structural fire design	Apr-07	Mar-09

Used	Eurocode Part	Title	Publication Date	UK National Annex Publication Date
	BS EN 1999-1-3	Design of aluminium structures – Part 1-3 Structures susceptible to fatigue.	Aug-07	Dec-08
	BS EN 1999-1-4	Design of aluminium structures – Part 1-4 Cold formed structural sheeting	Apr-07	Mar-09
	BS EN 1999-1-5	Design of aluminium structures – Part 1-5: Supplementary rules for shell structures	Apr-07	Mar-09

BSI Published Documents

Used	Document Reference	Title
BSI Published Documents		
✓	PD 6688-1-1	Background paper to the UK National Annex to BS EN 1991-1-1
✓	PD 6688-1-4	Background paper to the UK National Annex to BS EN 1991-1-4
✓	PD 6688-1-7	Recommendations for the design of structures to BS EN 1991-1-7
✓	PD 6688-2	Recommendations for the design of structures to BS EN 1991-2
✓	PD 6687-1	Background paper to the UK National Annex to BS EN 1992-1 and BS EN 1992-3
✓	PD 6687-2	Recommendations for the design of structures to BS EN 1992-2
✓	PD 6694-1	Recommendations for the design of structures subject to traffic loading to BS EN 1997-1:2004
✓	PD 6695-1-9	Recommendations for the design of structures to BS EN 1993-1-9
✓	PD 6695-1-10	Recommendations for the design of structures to BS EN 1993-1-10
✓	PD 6695-2	Recommendations for the design of bridges to BS EN 1993
	PD 6696-2	Background paper to BS EN 1994-2 and the UK National Annex to BS EN 1994-2
✓	PD 6698	Recommendations for the design of structures for earthquake resistance to BS EN 1998
✓	PD 6703	Structural bearings – Guidance on the use of structural bearings
✓	PD 6705-2	Recommendations on the execution of steel bridges to BS EN 1090-2

Execution Standards

Used	Document Reference	Title	Date
✓	BS EN 1090-1 +A1:2011	Execution of steel structures and aluminium structures. Requirements for conformity assessment of structural components	2009
✓	BS EN 1090-2 +A1:2011	Execution of steel structures and aluminium structures. Technical requirements for steel structures	2008
✓	BS EN 1090-3:2008	Execution of steel structures and aluminium structures. Technical requirements for aluminium structures	2008
✓	BS EN 13670:2009	Execution of concrete structures	2009
✓	BS EN 1536:2000	Execution of special Geotechnical Work – Bored Piles	2000

Product Standards referenced in British Standards or Eurocodes

Used	Document Ref	Title	Date
✓	BS EN 206-1	Concrete. Specification, performance, production and conformity	2000
✓	BS EN 1317-1-2010	Road Restraints Systems – Part 1, Terminology and general criteria for test methods	2010
✓	BS EN 1317-2-2010	Road Restraints Systems – Part 2, Performance classes, impact test acceptance criteria and test methods for safety barriers	2010
✓	BS EN 1317-3-2010	Road Restraints Systems – Part 3, Performance classes, impact test acceptance criteria and test methods for crash cushions	2010
✓	DD ENV 1317-4-2002	Road Restraints Systems – Part 4, Performance classes, impact test acceptance criteria and test methods for terminals and transitions of safety barriers	2002
✓	BS EN 1337	Structural Bearings, Parts 1 - 11.	Various
✓	BS EN 10025	Hot rolled products of structural steels, Pt 1 to 6	2004
✓	BS EN 10080	Steel for the reinforcement of concrete. Weldable reinforcing steel	2005
✓	BS EN 10210	Hot finished structural hollow sections of non-alloy and fine grain steels, Parts 1 and 2	2006
✓	BS EN 15050	Precast concrete products - Bridge elements	2007
	BS EN 14844 (+A2: 2011)	Box culverts	2006

✓	BS EN 15258	Retaining wall elements	2008
	BS EN 12843	Masts and poles	2004
	BS EN 12794	Foundation piles	2005

British Standards

✓	BS 4449:2005 +A2:2009	Steel for the reinforcement of concrete: Weldable reinforcing steel – Bar, coil and decoiled product – Specification	2009
	BS 5896; 1980 (inc Amdt No.1)	Specification for high tensile steel wire and strand for the prestressing of concrete	1980
✓	BS 8002; 1994	Earth retaining structures	1994
✓	BS 8004; 1986	Foundations	1986
	BS 8006; 1995	Strengthened/reinforced soils and other fills	1995
✓	BS 8500:	Concrete - Complementary British Standard to BS EN 206-1:	
✓	Part 1; 2006	Method of specifying and guidance for the specifier	2016
✓	Part 2; 2006	Specification for constituent materials and concrete	2016
✓	BS 8666:2005	Scheduling, dimensioning, bending and cutting of steel reinforcement for concrete- Specification	2005
✓	BS 7818:1995	Specification for pedestrian restraint systems in metal	1995
✓	BS EN 13369 (+A1: 2006)	Common rules for precast concrete products	2004

Miscellaneous Standards

✓		International Building Code	2012
✓		Bermuda Building Code	2014
✓		Bermuda Residential Building Code	2014
✓		AASHTO LFRD Bridge Design Specifications 7th Edition	2014
✓		AASHTO BVCS Bridges Vulnerable to Coastal Storms	2008
✓	CIRIA C 766	Control of cracking caused by restrained deformation in concrete	2018

Rev P02

The Manual of Contract Documents for Highway Works (MCDHW)

Volume 1: Specification for Highway Works, Amendment Feb 2016	✓
---	---

Volume 2: Notes for Guidance on the Specification for Highway Works, Amendment Feb 2016	✓
Volume 3: Highway Construction Details, Amendment Nov 2008	✓

The Design Manual for Roads and Bridges (DMRB)

Bridges and Structures, Advice Notes (BA Series)				
BA 9/81	The Use of BS 5400: Part 10: 1980. Code of Practice for Fatigue Amendment No. 1	Dec 1981 Nov 1983	1.3	
BA 16/97	The Assessment of Highway Bridges and Structure Amendment No. 1 Amendment No. 2	May 1997 Nov 1997 Nov 2001	3.4.4	
BA 19/85	The Use of BS 5400: Part 3: 1982	Jan 1985	1.3	
BA 26/94	Expansion Joints for Use in Highway Bridge Decks	Nov 1994	2.3.7	✓
BA 28/92	Evaluation of Maintenance Costs in Comparing Alternative Designs for Highway Structures	Aug 1992	1.2.2	
BA 35/90	Inspection and Repair of Concrete Highway Structures	Jun 1990	3.3	
BA 36/90	The Use of Permanent Formwork	Feb 1991	2.3	✓
BA 37/92	Priority Ranking of Existing Parapets	Oct 1992	2.3.2	
BA 38/93	Assessment of the Fatigue Life of Corroded or Damaged Reinforcing Bars	Oct 1990	3.4.5	
BA 39/93	Assessment of Reinforced Concrete Half-joints	Apr 1993	3.4.6	
BA 40/93	Tack Welding of Reinforcing Bars	Apr 1993	1.3.4	
BA 41/98	The Design and Appearance of Bridges	Feb 1998	1.3.11	✓
BA 42/96	The Design of Integral Bridges [Incorporating Amendment No.1 dated May 2003]	Nov 1996	1.3.12	✓
BA 47/99	Waterproofing and Surfacing Concrete Bridge Decks	Aug 1999	2.3.5	✓
BA 51/95	The Assessment of Concrete Structures Affected by Steel Corrosion	Feb 1995	3.4.13	
BA 52/94	The Assessment of Concrete Highway Structures Affected by Alkali Silica Reaction	Nov 1994	3.4.10	
BA 53/94	Bracing Systems and the Use of U-Frames in Steel Highway Bridges	Dec 1994	1.3.13	
BA 54/94	Load Testing for Bridge Assessment	Apr 1994	3.4.8	
BA 55/06	The Assessment of Bridge Substructures and Foundations, Retaining Walls and Buried Structures	May 2006	3.4.9	
BA 57/01	Design for Durability	Aug 2001	1.3.8	✓
BA 58/94	Design of Bridges and Concrete Structures with External Unbonded Prestressing	Nov 1994	1.3.10	
BA 59/94	Design of Highway Bridges for Hydraulic Action	May 1994	1.3.6	✓
BA 67/96	Enclosure of Bridges	Aug 1996	2.2.8	
BA 72/03	Maintenance of Road Tunnels	May 2003	3.2.3	
BA 82/00	Formation of Continuity Joints in Bridge Decks	Nov 2000	2.3.7	
BA 83/02	Cathodic Protection for Use in Reinforced Concrete Highway Structures	Feb 2002	3.3.3	
BA 85/04	Coatings for Concrete Highway Structures & Ancillary Structures	May 2004	2.4.3	

BA 86/06	Advice Notes on the Non-Destructive Testing of Highway Structures	Aug 2006	3.1.7	
BA 87/04	Management of Corrugated Steel Buried Structures Correction No.2	Aug 2004 Nov 2009	3.3.4	
BA 88/04	Management of Buried Concrete Box Structures	Aug 2004	3.3.5	
BA 92/07	The Use of Recycled Aggregates in Structural Concrete	May 2007	2.3.9	✓
BA 93/09	Structural Assessment of Bridges with Deck Hinges	Feb 2009	3.1.5	
Bridges and Structures, Standards (BD Series)				
BD 2/12	Technical Approval of Highway Structures	Aug 2005	1.1.1	✓
BD 7/01	Weathering Steel for Highway Structures	Nov 2001	2.3.8	
BD 9/81	Implementation of BS 5400: Part 10: 1980. Code of Practice for Fatigue	Dec 1981	1.3	
BD 10/97	Design of Highway Structures in Areas of Mining Subsidence	May 1997	1.3.14	
BD 12/01	Design of Corrugated Steel Buried Structures with Spans Greater than 0.9 Metres and up to 8.0 Metres	Nov 2001	2.2.6	
BD 13/06	Design of Steel Bridges. Use of BS 5400-3: 2000	May 2006	1.3.14	
BD 15/92	General Principles for the Design and Construction of Bridges. Use of BS 5400: Part 1: 1988	Dec 1992	1.3.2	
BD 16/82	Design of Composite Bridges. Use of BS 5400:Part 5:1979 Amendment No.1	Nov 1982 Dec 1987	1.3	
BD 20/92	Bridge Bearings. Use of BS 5400: Part 9: 1983	Oct 1992	2.3.1	
BD 21/01	The Assessment of Highway Bridges and Structures	May 2001	3.4.3	
BD 27/86	Materials for the Repair of Concrete Highway Structures	Nov 1986	3.3	
BD 29/04	Design Criteria for Footbridges	Aug 2004	2.2.8	
BD 30/87	Backfilled Retaining Walls and Bridge Abutments	Aug 1987	2.1	✓
BD 31/01	The Design of Buried Concrete Box and Portal Frame Structures	Nov 2001	2.2.12	
BD 33/94	Expansion Joints for Use in Highway Bridge Decks	Nov 1994	2.3.6	✓
BD 35/14	Quality Assurance Scheme for Paints and Similar Protective Coatings	May 2006	2.4.1	✓
BD 36/92	Evaluation of Maintenance Costs in Comparing Alternative Designs for Highway Structures (See Appendix B)	Aug 1992	1.2.1	
BD 37/01	Loads for Highway Bridges	Aug 2001	1.3.14	
BD 43/03	The Impregnation of Reinforced and Prestressed Concrete Highway Structures using Hydrophobic Pore-Lining Impregnants	Feb 2003	2.4.2	
BD 44/15	The Assessment of Concrete Highway Bridges and Structures	Jan 1995	3.4.14	
BD 45/93	Identification Marking of Highway Structures	Aug 1993	3.1.1	
BD 47/99	Waterproofing and Surfacing of Concrete Bridge Decks	Aug 1999	2.3.4	

BD 48/93	The Assessment and Strengthening of Highway Bridge Supports	Jun 1993	3.4.7	
BD 49/01	Design Rules for Aerodynamic Effects on Bridges	May 2001	1.3.3	
BD 51/14	Portal and Cantilever Signs/Signal Gantries	May 1998	2.2.4	
BD 53/95	Inspection and Records for Road Tunnels	Jul 1995	3.1.6	
BD 54/15	Post-tensioned Concrete Bridges Prioritisation of Special Inspections	Apr 1993	3.1.2	
BD 56/10	The Assessment of Steel Highway Bridges and Structures	Nov 1996	3.4.11	
BD 57/01	Design for Durability	Aug 2001	1.3.7	✓
BD 58/94	The Design of Concrete Highway Bridges and Structures with External and Unbonded Prestressing	Nov 1994	1.3.9	
BD 60/04	Design of Highway Bridges for Vehicle Collision Loads	May 2004	1.3.5	
BD 61/10	The Assessment of Composite Highway Bridges and Structures	Nov 1996	3.4.16	
BD 62/07	As Built, Operational and Maintenance Records for Highway Structures	Feb 2007	3.2.1	
BD 63/07	Inspection of Highway Structures	Feb 2007	3.1.4	
BD 65/14	Design Criteria for Collision Protector Beams	Feb 1997	2.2.5	
BD 67/96	Enclosure of Bridges	Aug 1996	2.2.7	
BD 70/03	Strengthened/Reinforced Soils and Other Fills for Retaining Walls and Bridge Abutments. Use of BS8006: 1995, incorporating Amendment No.1 (Issue 2 March 1999)	May 2003	2.1.5	
BD 78/99	Design of Road Tunnels	Aug 1999	2.2.9	
BD 79/13	The Management of Sub standard Highway Structures	Aug 2006	3.4.18	
BD 81/02	Use of Compressive Membrane Action in Bridge Decks	May 2002	3.4.20	
BD 82/00	Design of Buried Rigid Pipes	Aug 2000	2.2.10	
BD 84/02	Strengthening of Concrete Bridge Supports Vehicle Impact Using Fibre Reinforced Polymers	Aug 2002	1.3.16	
BD 85/08	Strengthening Highway Structures Using Externally Bonded Fibre Reinforced Polymer	Nov 2008	1.3.18	
BD 86/11	The Assessment of Highway Bridges and Structures For The Effects of Special Types General Order (STGO) and Special Order (SO) Vehicles	Nov 2007	3.4.19	
BD 87/05	Maintenance Painting of Steelwork	May 2005	3.2.2	
BD 89/03	The Conservation of Highway Structures	Nov 2003	3.2.4	
BD 90/05	Design of FRP Bridges and Highway Structures	May 2005	1.3.17	
BD 91/04	Unreinforced Masonry Arch Bridges	Nov 2004	2.2.14	
BD 94/07	Design of Minor Structures	Feb 2007	2.2.1	
BD 95/07	Treatment of Existing Structures on Highway Widening Schemes	Aug 2007	1.2.3	
BD 97/12	The Assessment of Scour and Other Hydraulic Actions at highway Structures	May 2012	3.4.21	
BD 100/16	The Use of Eurocodes for the Design of Highway Structures	Nov 2016	1.3.19	✓

BD 101/11	Structural Review and Assessment of Highway Structures	Nov 2100	3.4.22	
Bridges and Structures, Technical Memoranda (BE Series)				
BE 13	Fatigue Risk in Bailey Bridges	Apr 1968	3.4	
BE 23	Shear Key Decks Amendment No. 1 to Annex	Nov 1970 June 1971	1.3	
BE 5/75	Rules for the Design and Use of Freyssinet Concrete Hinges in Highway Structures	Mar 1975	1.3	
BE 7/04	Departmental Standard (Interim) Motorway Sign/Signal Gantries	Aug 2004	2.2	
Traffic Engineering and Control, Standards (TA and TD Series)				
TD 9/93	Highway Link Design Amendment No. 1	Jun 1993 Feb 2002	6.1.1	✓
TD 19/06	Requirement for Road Restraint Systems	Aug 2006	2.2.8	✓
TD 27/05	Cross Sections and headroom	Feb 2005	6.1.2	
TD 36/93	Subways for pedestrians and cyclists, layout and dimensions	Jul 1993	6.3.1	
Highways, Advice Notes (HA Series)				
HA 66/95	Environmental Barriers - Technical Requirements	Sep 1995	10.5.2	
Highways, Standards (HD Series)				
HD 22/08	Managing Geotechnical Risks	Aug 2008	4.1	✓

Interim Advice Notes

124/11 (Jul 11)	Use of Eurocodes for the design of highway structures	✓
122/09 (Jun 09)	Rapid Condition Assessment of Hard Shoulder Pavements. Interim guide to data and maintenance advice	
121/09 (Jun 09)	Advice regarding implementation of Integrated Traffic Management	
117/08 Rev 1 (Jun 09)	Certification of combined kerb and drainage products	
116/08 (Oct 08)	Nature Conservation in Relation to bats	
115/08 (Nov 08)	Hard shoulder working	
114/08 (Sep 08)	Highways agency carbon calculation and reporting requirements	
113/08 (Jul 08)	Temporary Automatic Speed Camera System for the Enforcement of Mandatory Speed Limits at Roadworks (TASCAR)	
112/08 (Jun 08)	Managed Motorway Implementation Guidance – Through Junction Hard Shoulder Running [PR 100/08]	
111/08 (Jun 08)	Managed Motorway Implementation Guidance – Dynamic Use of Hard Shoulder [PR 99/08]	
110/08 (Apr 08)	Assessment of Implications (Of Highways Plans and Projects) On European Sites (Including Appropriate Assessment)	
109/08 (Apr 08)	Advice Regarding the Motorway Signal Mark 4 (MS4)	
107/08 (Feb 08)	Variable Demand Modelling As Part Of A Transport Assessment For The Highways Agency	
106/08 (Jan 08)	Guidance Note for Traffic Consultants Employed on Highways Agency Schemes	
105/08 (Jan 08)	Implementation of Construction (Design and Management) 2007 and the withdrawal of SD 10 and SD 11	
104/07 (Dec 07)	The Anchorage of Reinforcement & Fixings in Hardened Concrete	✓

103/08 (Mar 08)	Ramp metering	
100/07 (Oct 07)	Cultural Heritage Asset Management Plans	
99/07 (Nov 07)	Implementation of Local Grid Referencing System for England	
98/07 (Sep 07)	HD 28 Guidance for HA Service Providers on Implementing the Skid Resistance Policy	
97/07 (Aug 07)	Assessment and Upgrading of Existing Parapets	
96/07r1 (Aug 07)	Guidance On Implementing Results Of Research On Bridge Deck Waterproofing	✓
95/07 (May 07)	Revised guidance regarding the use of BS8500(2006) for the design and construction of structures using concrete.	✓
93/07 (Apr 07)	Driver location signs – Interim Performance Specification	
91/07 (Mar 07)	Interim Advice on the identification of 'Particularly at Risk' Supports	
90/07 Rev 01 (Apr 07)	Guidance For The Use Of Rapid Setting Emergency Repair Materials	
87/07 (Mar 07)	The Provision Of Signal Gantries For Motorways With Four Or More Running Lanes	
86/07 (Jun 07)	Amendments to design requirements for Portal and cantilever Sign/Signal Gantries.	
85/07 (Jun 07)	Design of Passively Safe Portal Signal Gantries	
84/07 (Jul 07)	Environmental Information System (EnvIS)	
83/06 (Jun 06)	Principal and General Inspection of Sign/Signal Gantries, and Gantries with low handrails or open mesh flooring.	
75/06 (May 06)	Code of Practice for Emergency Access to and Egress from the Trunk Road Network in England	
73/06 Rev 1 (Feb 09)	Design of Pavement Foundations	
71/06 (Feb 06)	Marker Posts On Lay-By Segregation Islands	
70/06 (Jan 06)	Implementation of New Reinforcement Standards (BS 4449:2005, BS 4482:2005, BS 4483:2005 and BS 8666:2005)	✓
69/05 (Dec 05)	Designing for Maintenance	✓
68/05 (May 06)	Infrastructure changes to improve emergency access to and egress from the trunk road network in England	
64/05 (Apr 05)	Driver Information At Road Works	
63/05r1 (Feb 07)	Asbestos Management Applicable to the Strategic Road Network	
56/04 (Aug 04)	Maintenance Of Traffic Signs With Dew Resistant Coatings	
53/04 (Feb 04)	Concrete Half-Joint Deck Structures	
51/03 (Jul 03)	Hinge Deck Structures	
49/03 (Mar 03)	Use of Warning Signs For New Asphalt Road Surfaces	
48/03 (Jan 03)	Measures to Minimise the Risk of Sulphate Attack (Including Thaumasite) – New Construction and Structures Under Construction	✓
47/02 (Dec 02)	Post Tensioned Grouted Duct Concrete Bridges	
41/02 (Jan 02)	European Cement Standards	✓
39/01 (Jun 01)	Post Opening Project Appraisal (POPE)	
36/01 (Jun 01)	The Use and Application of Micro-Simulation and Traffic Models	
05/96 (July 96)	BD 24/92 The Design of Concrete Highway Bridges and Structures. Use of BS 5400: Part 4: 1990	
04/96 (July 96)	BD 44/95 The Assessment of Concrete Highway Bridges and Structures	
03/96 (June 96)	BA 50/93 Post Tensioned Concrete Bridges	
01/95 (Oct 95)	TD 37/93 Scheme Assessment Reporting	

APPENDIX 2 DIAGRAM OF IDEALISED STRUCTURE

Rev P02

The idealised structure for Longbird Bridge Replacement is illustrated in Figure 8 below. The hangers will be designed as tension only elements.

Rev P02

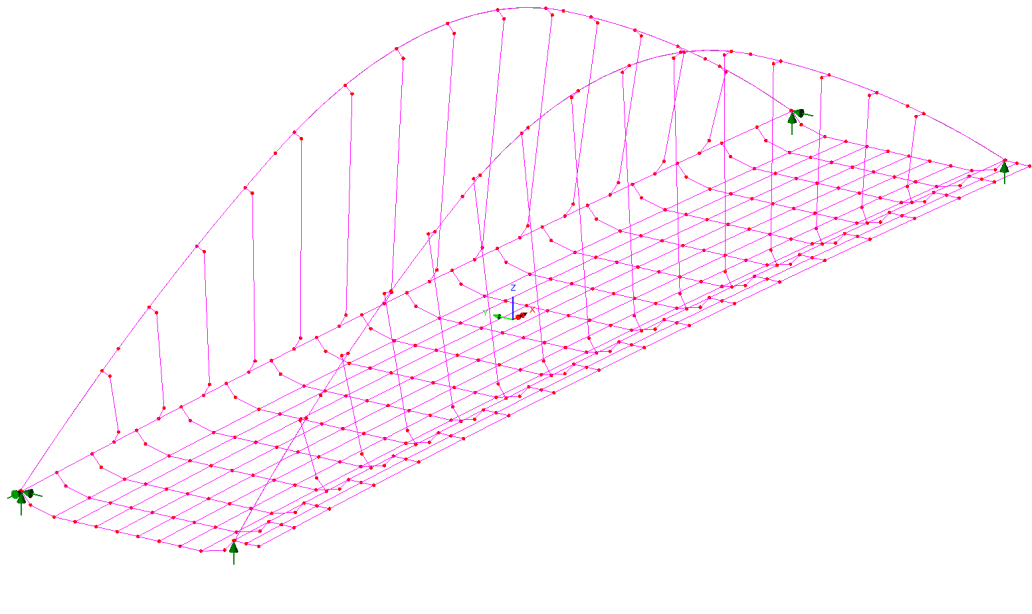

Figure 8 - Idealised structure diagram

For bridge articulation diagram refer to drawing 3502-RAM-LB-XX-DR-CB-30002 in Appendix 4.

APPENDIX 3 DESIGNER'S RISK ASSESSMENTS

CDM DESIGNER'S RISK ASSESSMENT

Project Name: Longbird Bridge Replacement		Job No: 1620003502		Document Ref:			
Stage / Section of works:			Issue date/rev:		Project Director Approval:		
Item No.	Activity or Element Reference	Design item giving rise to hazard	Consequence of item giving rise to risk	Persons at Risk		Design action to eliminate risk or reduce risk	Residual Risks
		What decisions are being made or what is being designed which is creating a hazard	What are the probable consequences of this design item	Site	Others		
A	General						
A01	Construction	Construction of carriageway/footway/retaining structures/parapets/fencing/curb	Site workers falling from height. Materials & equipment falling from height and injuring persons below.	X		Minimise size/weight of elements with efficient design as far as possible. Show elevation on construction drawings to indicate the height from the water level to top of deck surfacing.	Contractor to implement suitable staff training and certification for working at heights along with ensuring that proper PPE is worn and that safety precautions to the OSHA/NEBOSH regulations are implemented Contractor to ensure qualified persons operate cranes or other lifting equipment. Contractor to ensure that the site is adequately supervised to minimise the risk to the workers. Automated mechanical methodology to be employed where practical to avoid working at height by personnel. Residual work at height/manual handling and ergonomics to be considered at detailed design. Consider temporary safety fencing and vehicle blocks to prevent construction workers and vehicles falling down.

CDM DESIGNER'S RISK ASSESSMENT

Project Name: Longbird Bridge Replacement		Job No: 1620003502		Document Ref:			
Stage / Section of works:			Issue date/rev:		Project Director Approval:		
Item No.	Activity or Element Reference	Design item giving rise to hazard	Consequence of item giving rise to risk	Persons at Risk		Design action to eliminate risk or reduce risk	Residual Risks
		What decisions are being made or what is being designed which is creating a hazard	What are the probable consequences of this design item	Site	Others		
A02	Construction	Construction of carriageway/footway/retaining structures/parapets/fencing/curb/piers/foundations	Drowning Plant slippage	X		Where practical, cofferdams were proposed to create a safe working area.	Ensure safe site area with adequate life saving equipment and provision of safety boat during works on or near water edge. Consider proximity to water in design and provide suitable welfare facilities and adequate PPE on site.
A03	Construction	Unknown Services, Utilities and Obstruction including Existing underground/overhead services	Damage to services (e.g. HV cables) Risk to injury/death by electrocution/explosion	X	X	Services enquiries will be undertaken and all known service locations will be shown on the drawings. The design will avoid disruption (e.g. clashes and diversion works) to services as much practicable as possible. Drawings will clearly highlight where services may be affected by works.	Services to be traced prior to dig and thus identified on drawings supplied. Contractor to arrange diversions as required. Works to be completed by appropriate personnel. Radio and electro-detection of services should be undertaken on site everytime an excavation is to take place
A04	Construction	Working alongside and adjacent to a live carriageway	Risk of injury or death from road users colliding with site workers and machinery. Potential for collision/conflict with local traffic due to road closure or traffic diversions.	X	X	N/A	Contractor to develop and adopt methodology for safe working on/near live carriageways.

CDM DESIGNER'S RISK ASSESSMENT

Project Name: Longbird Bridge Replacement	Job No: 1620003502	Document Ref:
--	---------------------------	----------------------

Stage / Section of works:	Issue date/rev:	Project Director Approval:
----------------------------------	------------------------	-----------------------------------

Item No.	Activity or Element Reference	Design item giving rise to hazard	Consequence of item giving rise to risk	Persons at Risk		Design action to eliminate risk or reduce risk	Residual Risks
		What decisions are being made or what is being designed which is creating a hazard	What are the probable consequences of this design item	Site	Others	The measures to be taken such as alternatives to be designed, information to be transferred onto drawings or in other documentation	Information about the risks that cannot be designed out and require controls to be developed and implemented by others
A05	Construction	Hazardous materials/substance (e.g. asbestos and paint vapours)	Release of fibers into air, paint solvent vapours and general exposure causing prolonged injury to contractors workforce and general public.	X	X	Painting the inside of the box girder was designed out by specifying weathering steel with a sacrificial steel thickness allowance.	Contractor to conduct Hazardous Materials Survey and Asbestos Survey for the site area by certified inspectors. Contractor to ensure that there is appropriate ventilation and netting prior to painting.
A06	Construction	Contaminated ground	Exposure of hazardous materials/soils to workforce and general public. Release of contaminants/spread of pollution; removal and disposal if contaminated material/soil	X	X	All known contaminated land areas will be shown on the drawings.	Principal Designer/Contractor to ensure that they are satisfied with the accuracy of the Survey/Reports prior to commencement of any site works/activities. Ensure suitable surveys/desktop study is carried out where necessary to locate areas of contamination.

CDM DESIGNER'S RISK ASSESSMENT

Project Name: Longbird Bridge Replacement	Job No: 1620003502	Document Ref:
--	---------------------------	----------------------

Stage / Section of works:	Issue date/rev:	Project Director Approval:
----------------------------------	------------------------	-----------------------------------

Item No.	Activity or Element Reference	Design item giving rise to hazard	Consequence of item giving rise to risk	Persons at Risk		Design action to eliminate risk or reduce risk	Residual Risks
		What decisions are being made or what is being designed which is creating a hazard	What are the probable consequences of this design item	Site	Others	The measures to be taken such as alternatives to be designed, information to be transferred onto drawings or in other documentation	Information about the risks that cannot be designed out and require controls to be developed and implemented by others
A07	Construction	Deep excavations and groundworks	<p>Collapse of excavation/trench resulting in injury or death.</p> <p>Flooding of excavations - leading to drowning and loss of stability.</p>	X		<p>Minimise depth of excavation where possible using piles and pilecaps.</p> <p>Where practical, cofferdams were proposed to create a safe working area.</p>	<p>Contractor to implement suitable measures to ensure that the required excavation slope for stability is achieved.</p> <p>Contractor to ensure that excavation works do not undermine nearby structures.</p> <p>Contractor to ensure that they have the required geotechnical information prior to excavation works.</p> <p>Contractor to protect the edges of the excavation pit with substantial barriers to prevent falling injuries.</p>
A08	Construction	Excessive noise	Possible hearing impairments to workers from the pile driving noise.	X	X	N/A	<p>Contractor to implement suitable measures and to drive piles during non-peak hours and to ensure that all workers involved with the pile driving wear the required PPE for noise protection.</p> <p>Contractor to control/limit the amount of workers in the construction zone.</p>

CDM DESIGNER'S RISK ASSESSMENT

Project Name: Longbird Bridge Replacement	Job No: 1620003502	Document Ref:
--	---------------------------	----------------------

Stage / Section of works:	Issue date/rev:	Project Director Approval:
----------------------------------	------------------------	-----------------------------------

Item No.	Activity or Element Reference	Design item giving rise to hazard	Consequence of item giving rise to risk	Persons at Risk		Design action to eliminate risk or reduce risk	Residual Risks
		What decisions are being made or what is being designed which is creating a hazard	What are the probable consequences of this design item	Site	Others	The measures to be taken such as alternatives to be designed, information to be transferred onto drawings or in other documentation	Information about the risks that cannot be designed out and require controls to be developed and implemented by others
A09	Construction	Drainage - Pollution spillage along proposed bridge and carriageway during construction works.	Spillages will cause pollution of waterbody within the area	X	X	N/A	Suitable maintenance regime should be in place to ensure blockages and spillages are cleared. Suitable drainage will be required to be provided throughout the site, containment will be suggested during the detail design following a pollution prevention risk assessment recommendations
A10	Demolition	Demolition of existing Bridge deck, foundations and associated highway elements/structural items	Risk of collapse causing damage, injury or death from falling objects. Risk of asbestos	X	X	N/A	Ensure that demolition is carried out by competent demolition team. Principal Designer/Contractor to ensure Asbestos Survey is carried out prior to commencement of any site works/activities.
B	Bridges						
B01	Construction	Construction sequence	Changes to the defined construction sequence resulting in a possible structural collapse	X		Provide construction sequence with the construction drawings	The contractor is to agree any proposed changes to the construction sequence with the designer prior to undertaking the works.

CDM DESIGNER'S RISK ASSESSMENT

Project Name: Longbird Bridge Replacement		Job No: 1620003502		Document Ref:			
Stage / Section of works:			Issue date/rev:		Project Director Approval:		
Item No.	Activity or Element Reference	Design item giving rise to hazard	Consequence of item giving rise to risk	Persons at Risk		Design action to eliminate risk or reduce risk	Residual Risks
		What decisions are being made or what is being designed which is creating a hazard	What are the probable consequences of this design item	Site	Others		
B02	Construction	Lifting operations	<p>Crane instability due to excessive section loads.</p> <p>Muscular skeletal injuries arising due to manual handling of heavy components.</p> <p>Failure of structural element during lift.</p> <p>Crashing into existing bridge.</p> <p>Crushing of body parts/equipment between the bridge soffit and bearings.</p>	X	X	Steel arch sections designed to allow the full span to be split into two bifurcation sections and one mid section to reduce the lifting weights.	<p>Contractor is to ensure the stability and integrity of the steel box girders at all times.</p> <p>Contractor to ensure lifting equipment with a suitable load capacity is used and to ensure that workers wear the required PPE and are trained in lifting/maneuvering heavy objects.</p>
B03	Operation	Vehicle striking structural element	Structural failure of bridge.	X		<p>VRS installed along with a high containment kerb to veer vehicle wheels away from the arch hangers and arch rib.</p> <p>One arch hanger was designed to be redundant at any one time.</p> <p>Arch rib designed to resist vehicle impact</p>	Ensure adequate speed limit signage is implemented near the bridge site.

CDM DESIGNER'S RISK ASSESSMENT

Project Name: Longbird Bridge Replacement		Job No: 1620003502			Document Ref:		
Stage / Section of works:			Issue date/rev:		Project Director Approval:		
Item No.	Activity or Element Reference	Design item giving rise to hazard	Consequence of item giving rise to risk	Persons at Risk		Design action to eliminate risk or reduce risk	Residual Risks
		What decisions are being made or what is being designed which is creating a hazard	What are the probable consequences of this design item	Site	Others		
B06	Maintenance	Access into bearing inspection gallery	Inspectors getting hit and injured by moving traffic as they attempt to gain access into the inspection gallery	X	X	Access stairwell into the inspection gallery is positioned behind the VRS system to mitigate the risk of the inspector coming into contact with moving traffic.	Appropriate maintenance methodology to be developed by the highways authority, with suitable traffic management if required and appropriately trained operatives. Potential requirement for life saving equipment and provision of safety boat during works on or near parapets and water edge.
C Geotechnical							
C01	Construction	Unexploded Ordnance UXO	Explosion, contamination	X	X		Contractor to use the mitigation measures developed in conjunction with UXO consultant

APPENDIX 4 DRAWINGS

COPYRIGHT RAMBOLL UK LIMITED. ALL RIGHTS RESERVED. THIS DOCUMENT IS ISSUED FOR THE PARTY WHO COMMISSIONED IT AND FOR THE SPECIFIC PURPOSES CONNECTED WITH THE PROJECT ONLY. IT SHOULD NOT BE RELIED UPON BY ANY OTHER PARTY OR USED FOR ANY OTHER PURPOSE. RAMBOLL ACCEPTS NO RESPONSIBILITY OR LIABILITY WHICH MAY ARISE FROM RELIANCE OR USE OF THIS DOCUMENT OR THE DATA CONTAINED HEREIN BY ANY OTHER PARTY OR FOR ANY OTHER PURPOSE.

- Notes
- DO NOT SCALE FROM THIS DRAWING.
 - ALL DIMENSIONS ARE IN MILLIMETRES U.N.O.
 - ALL LEVELS ARE IN METRES ABOVE ORDNANCE DATUM U.N.O.

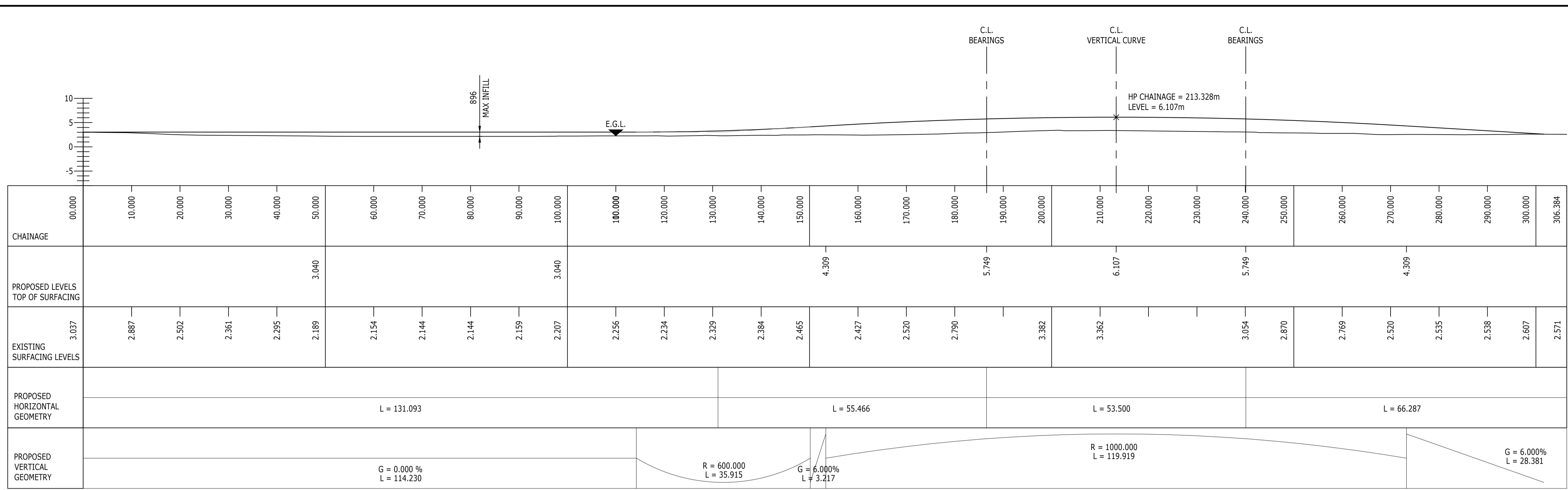

SECTION 1:500
PROPOSED ROAD ALIGNMENT LONG SECTION

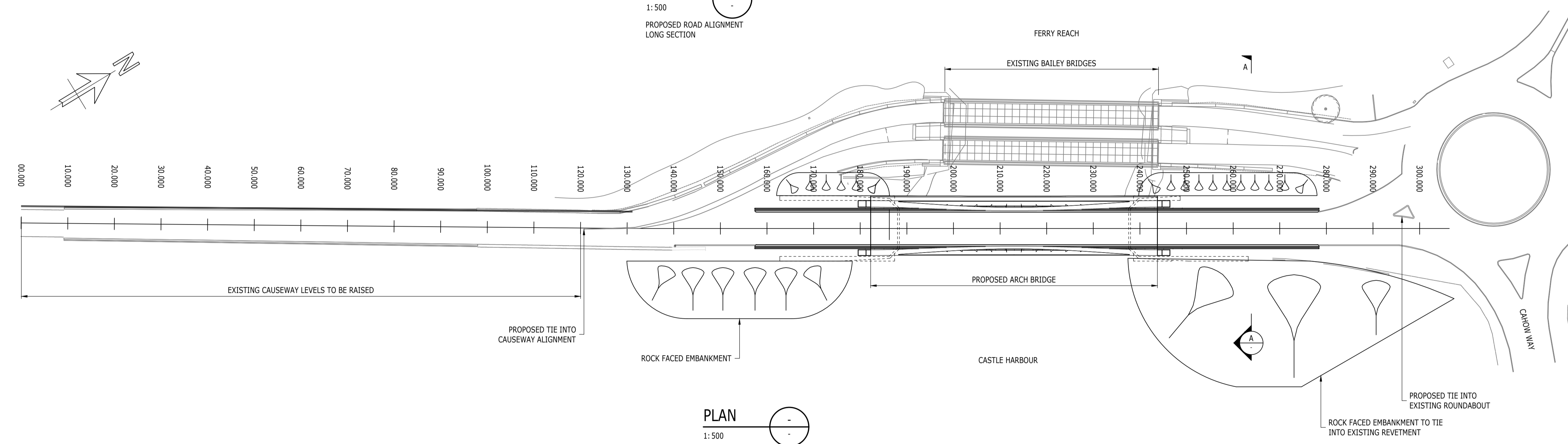

PLAN 1:500

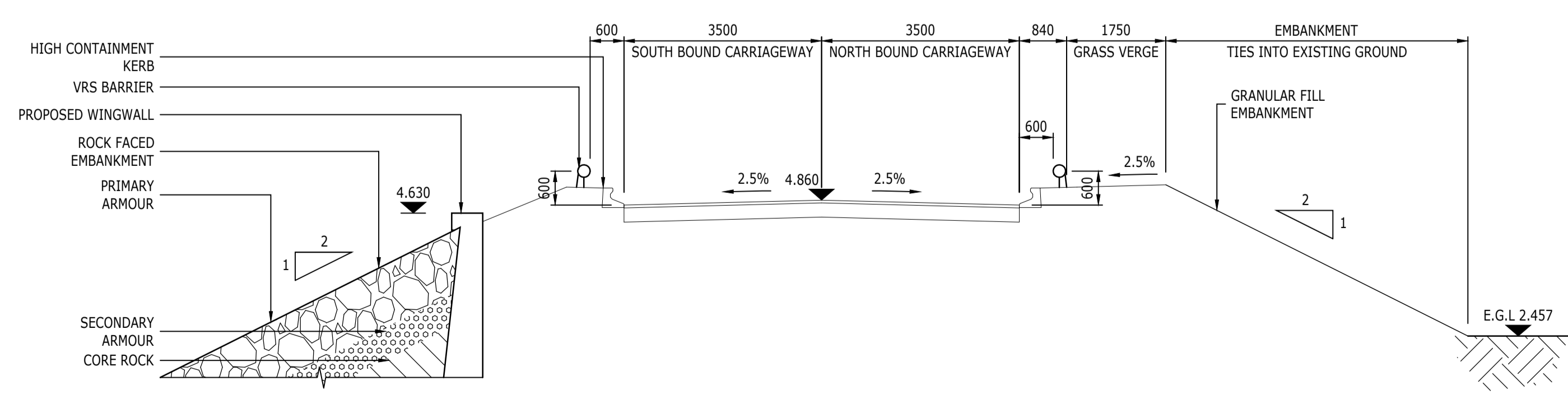

SECTION A-A 1:75

Rev	Description	Date	By	App
P01	PRELIMINARY	30/11/2018	CAB	SPT

PRELIMINARY



REPLACEMENT OF SWING BRIDGE & LONGBIRD BRIDGE, BERMUDA



Knight Architects



LONGBIRD BRIDGE REPLACEMENT
APPROVAL IN PRINCIPLE
GENERAL ARRANGEMENT
SHEET 1 OF 4

Project No:	Scale (B1):	Drawn:	Date:
1620003502	AS SHOWN	CAB	NOV.2018
Drawing No:	Rev:		
3502-RAM-LB-XX-DR-CB-30001	P01		

COPYRIGHT RAMBOLL UK LIMITED. ALL RIGHTS RESERVED. THIS DOCUMENT IS ISSUED FOR THE PARTY WHO COMMISSIONED IT AND FOR THE SPECIFIC PURPOSES CONNECTED WITH THE PROJECT ONLY. IT SHOULD NOT BE RELIED UPON BY ANY OTHER PARTY OR USED FOR ANY OTHER PURPOSE. RAMBOLL ACCEPTS NO RESPONSIBILITY OR LIABILITY WHICH MAY ARISE FROM RELIANCE OR USE OF THIS DOCUMENT OR THE DATA CONTAINED HEREIN BY ANY OTHER PARTY OR FOR ANY OTHER PURPOSE.

- Notes
- DO NOT SCALE FROM THIS DRAWING.
 - ALL DIMENSIONS ARE IN MILLIMETRES U.N.O.
 - ALL LEVELS ARE IN METRES ABOVE ORDNANCE DATUM U.N.O.

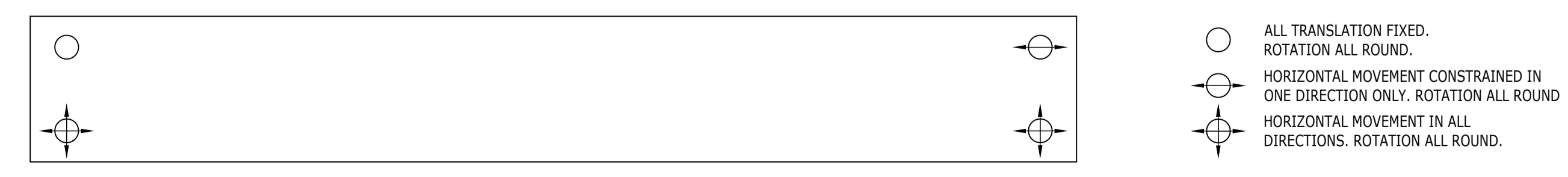
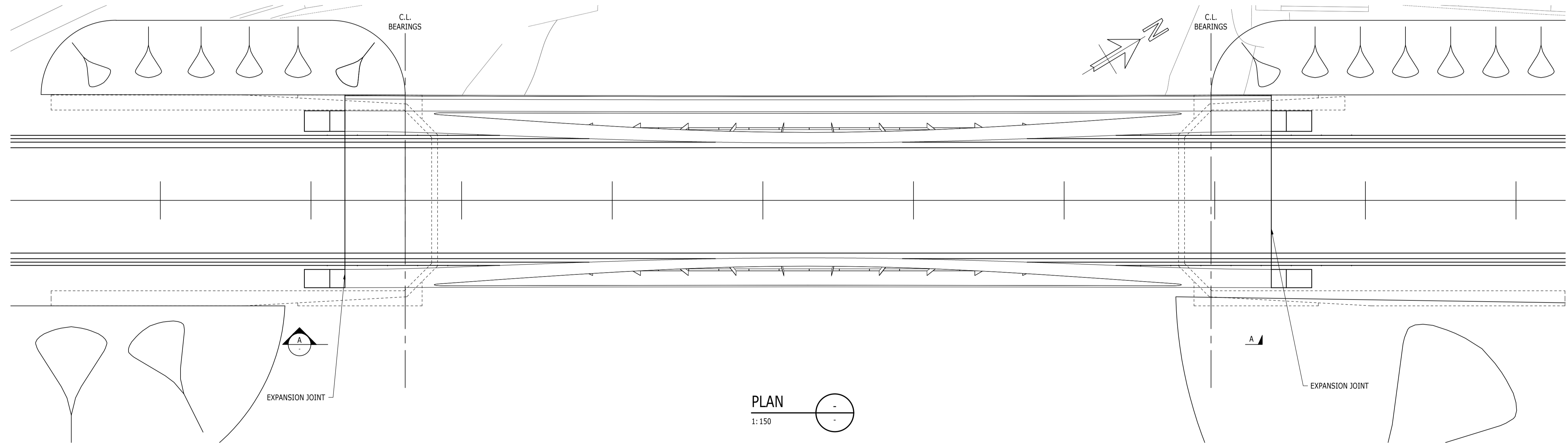
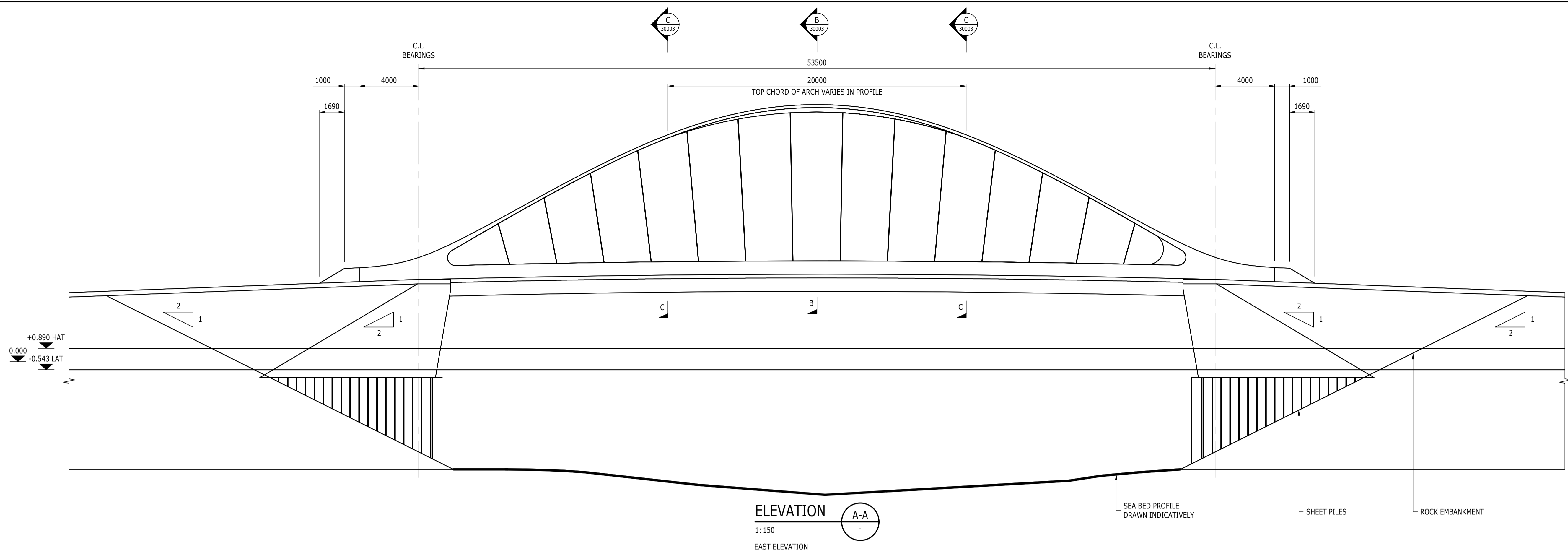

BEARING ARTICULATION
N.T.S.

P01	PRELIMINARY	30/11/2018	CAB	SPT
Rev	Description	Date	By	App

PRELIMINARY

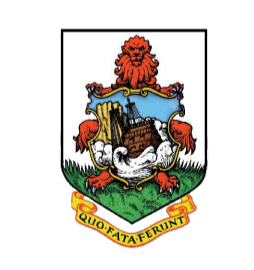

REPLACEMENT OF SWING BRIDGE & LONGBIRD BRIDGE, BERMUDA



**LONGBIRD BRIDGE REPLACEMENT
APPROVAL IN PRINCIPLE
GENERAL ARRANGEMENT
SHEET 2 OF 4**

Project No:	Scale (B41):	Drawn:	Date:
1620003502	AS SHOWN	CAB	NOV.2018
Drawing No:	Rev:		
3502-RAM-LB-XX-DR-CB-30002	P01		

COPYRIGHT RAMBOLL UK LIMITED. ALL RIGHTS RESERVED. THIS DOCUMENT IS ISSUED FOR THE PARTY WHO COMMISSIONED IT AND FOR THE SPECIFIC PURPOSES CONNECTED WITH THE PROJECT ONLY. IT SHOULD NOT BE RELIED UPON BY ANY OTHER PARTY OR USED FOR ANY OTHER PURPOSE. RAMBOLL ACCEPTS NO RESPONSIBILITY OR LIABILITY WHICH MAY ARISE FROM RELIANCE OR USE OF THIS DOCUMENT OR THE DATA CONTAINED HEREIN BY ANY OTHER PARTY OR FOR ANY OTHER PURPOSE.

- Notes
- DO NOT SCALE FROM THIS DRAWING.
 - ALL DIMENSIONS ARE IN MILLIMETRES U.N.O.
 - ALL LEVELS ARE IN METRES ABOVE ORDNANCE DATUM U.N.O.

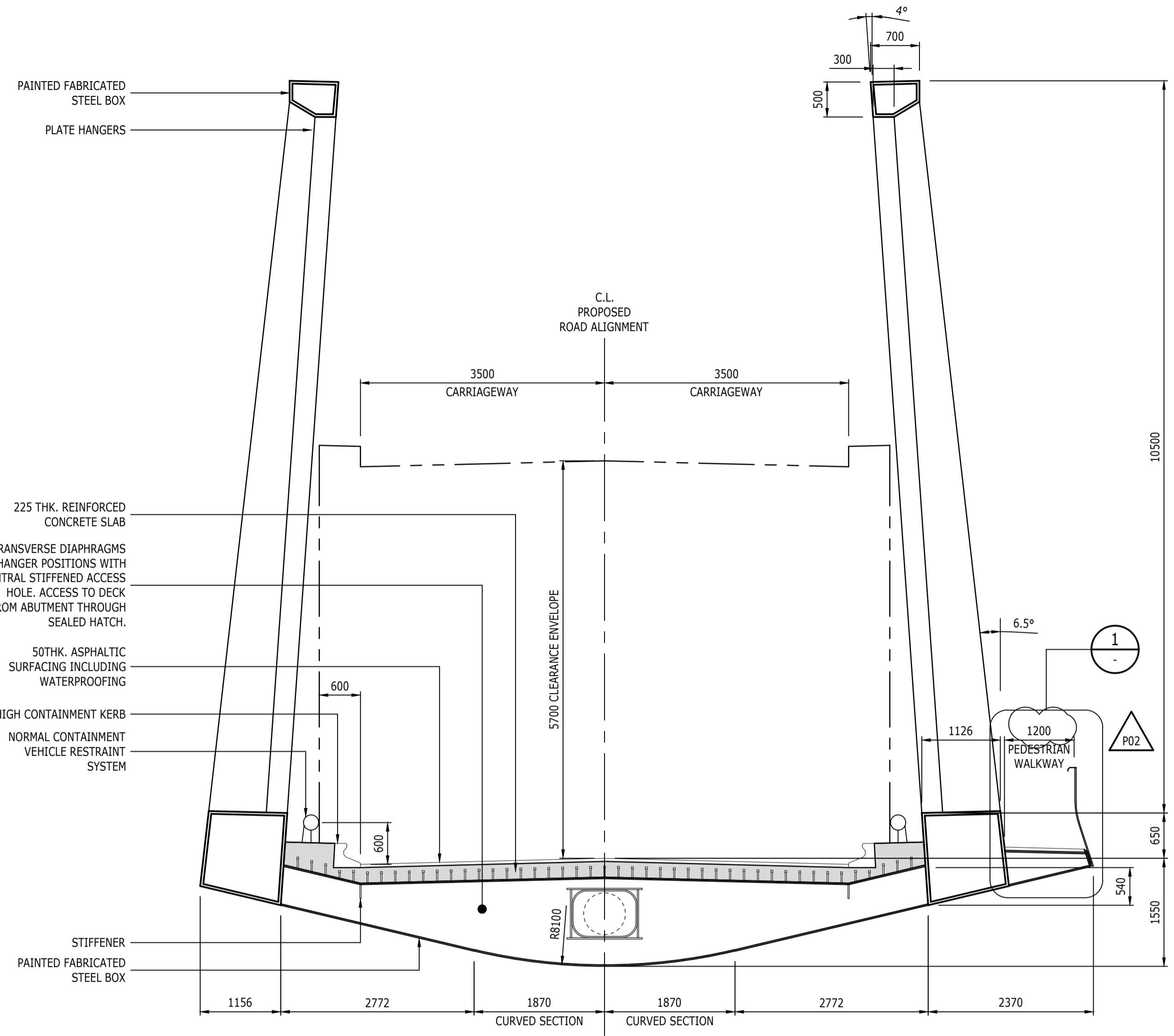

SECTION B-B
1:50
MID SPAN

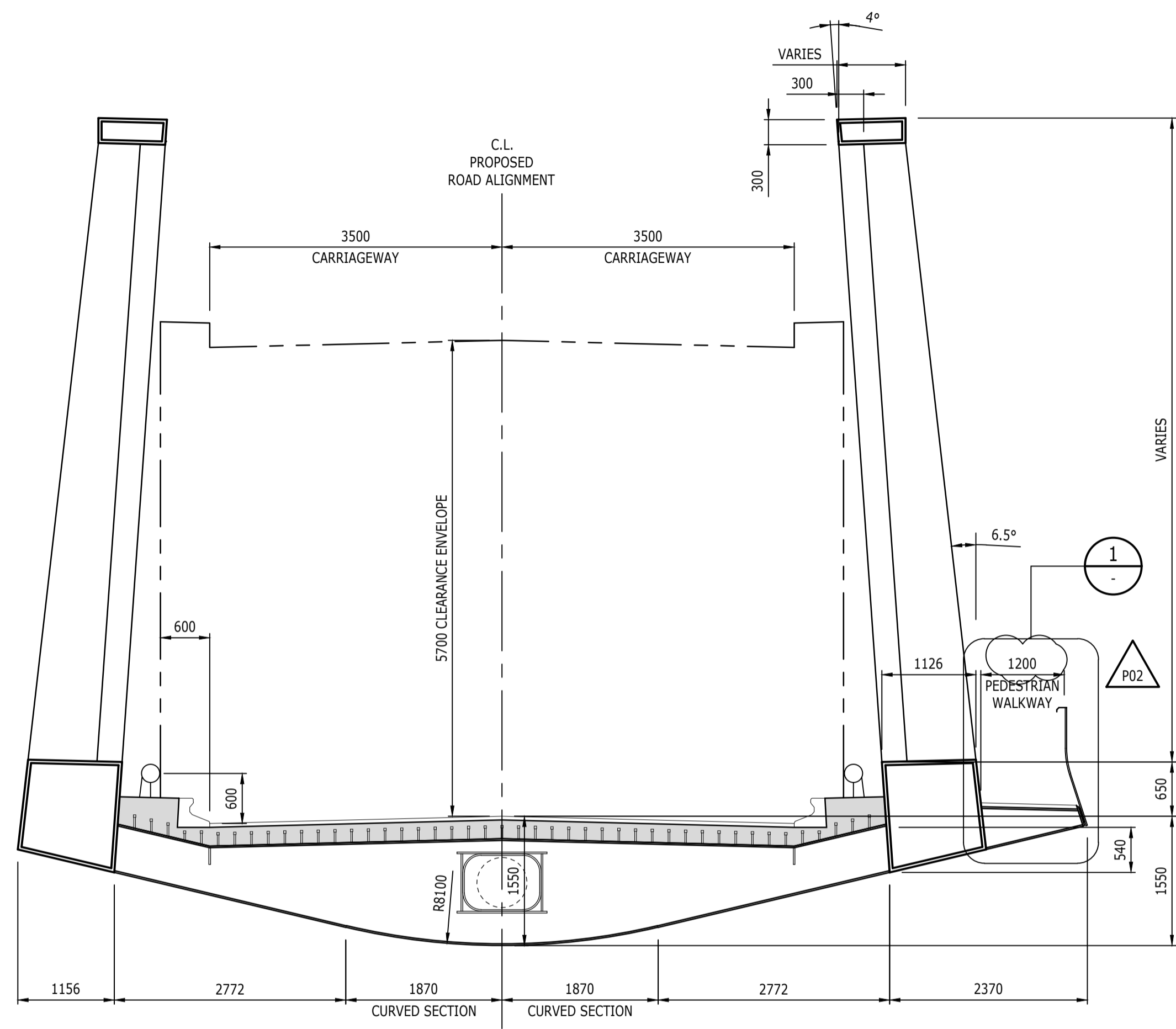

SECTION C-C
1:50
TYPICAL SECTION BETWEEN BIFURCATION & QUARTER SPAN

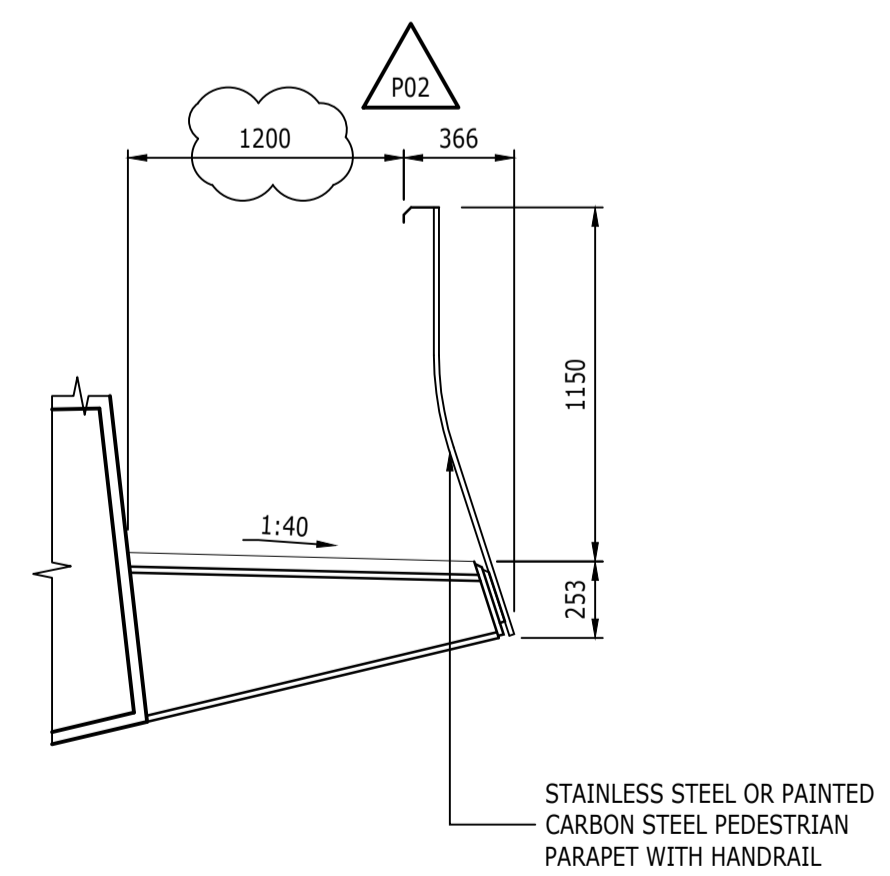

DETAIL 1
1:25
PEDESTRIAN FOOTWAY DETAIL

Rev	Description	Date	By	App
P02	REVISIONS CLOUDED	15/02 2019	JFRW	RZC SPT
P01	PRELIMINARY	30/11 2018	JFRW	CAB SPT

PRELIMINARY



REPLACEMENT OF SWING BRIDGE & LONGBIRD BRIDGE, BERMUDA



LONGBIRD BRIDGE REPLACEMENT APPROVAL IN PRINCIPLE GENERAL ARRANGEMENT SHEET 3 OF 4

Project No:	Scale (BA1):	Drawn:	Date:
1620003502	AS SHOWN	CAB	NOV.2018
Drawing No:	Rev:		
3502-RAM-LB-XX-DR-CB-30003	P02		

COPYRIGHT RAMBOLL UK LIMITED. ALL RIGHTS RESERVED. THIS DOCUMENT IS ISSUED FOR THE PARTY WHO COMMISSIONED IT AND FOR THE SPECIFIC PURPOSES CONNECTED WITH THE PROJECT ONLY. IT SHOULD NOT BE RELIED UPON BY ANY OTHER PARTY OR USED FOR ANY OTHER PURPOSE. RAMBOLL ACCEPTS NO RESPONSIBILITY OR LIABILITY WHICH MAY ARISE FROM RELIANCE OR USE OF THIS DOCUMENT OR THE DATA CONTAINED HEREIN BY ANY OTHER PARTY OR FOR ANY OTHER PURPOSE.

- Notes
- DO NOT SCALE FROM THIS DRAWING.
 - ALL DIMENSIONS ARE IN MILLIMETRES U.N.O.
 - ALL LEVELS ARE IN METRES ABOVE ORDNANCE DATUM U.N.O.

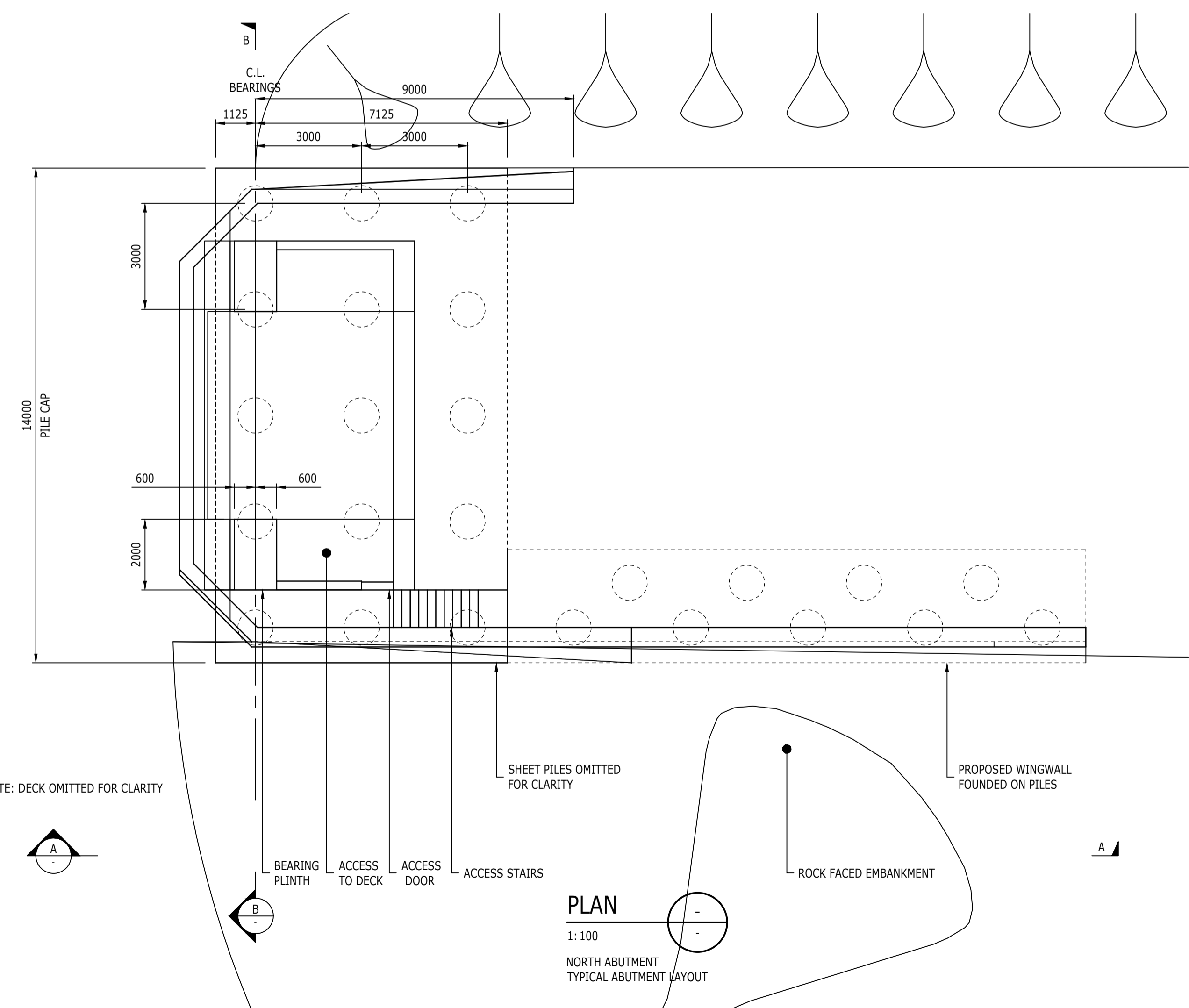
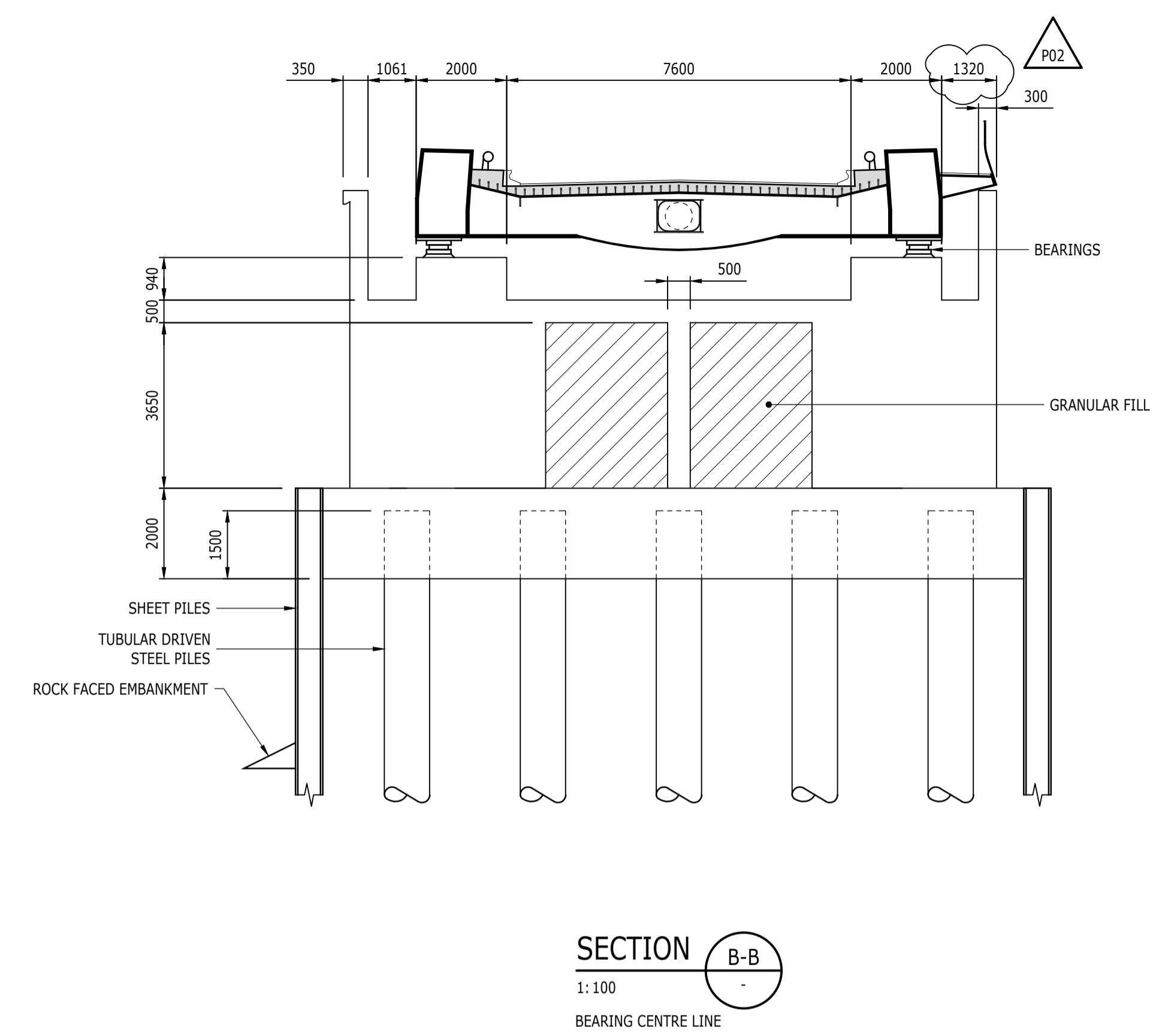
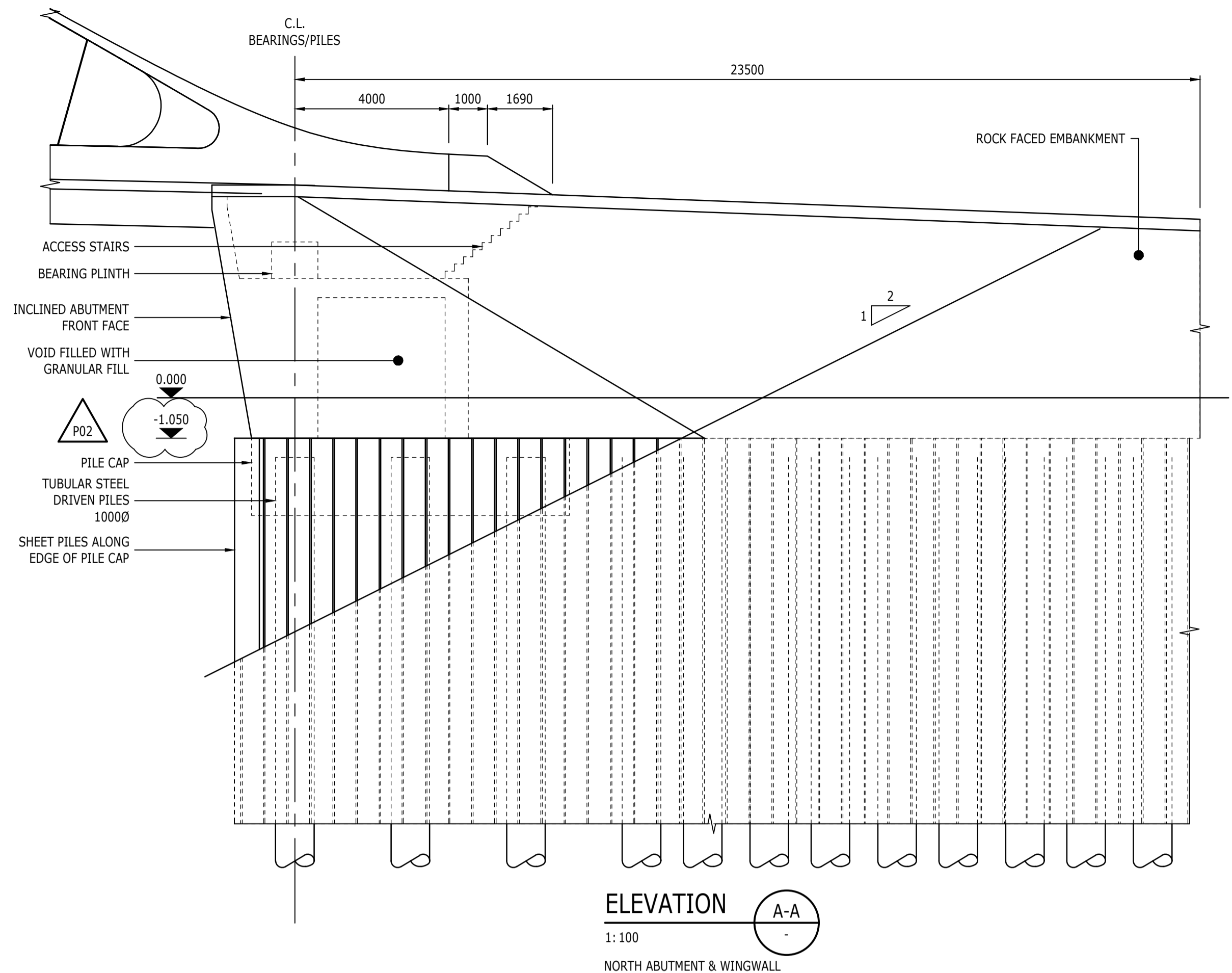

Rev	Description	Date	By	App
P02	REVISIONS CLOUDED	15/02 2019	RZC JFRW	SPT
P01	PRELIMINARY	30/11 2018	CAB JFRW	SPT

PRELIMINARY



REPLACEMENT OF SWING BRIDGE & LONGBIRD BRIDGE, BERMUDA



LONGBIRD BRIDGE REPLACEMENT
APPROVAL IN PRINCIPLE
GENERAL ARRANGEMENT
SHEET 4 OF 4

Project No: 1620003502	Scale (B41): AS SHOWN	Drawn: CAB	Date: NOV.2018
Drawing No: 3502-RAM-LB-XX-DR-CB-30004	Rev:	P02	

Notes
 1. DO NOT SCALE FROM THIS DRAWING.
 2. ALL DIMENSIONS ARE IN MILLIMETRES U.N.O.
 3. ALL LEVELS ARE IN METRES ABOVE ORDINANCE DATUM U.N.O.

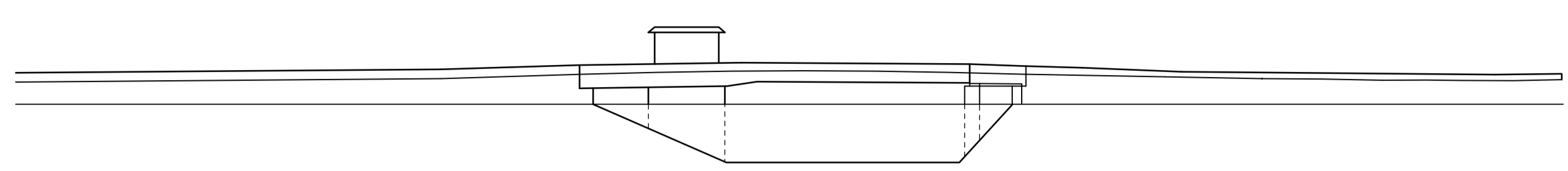

STAGE 0
 • EXISTING LONGBIRD BRIDGE STRUCTURE.

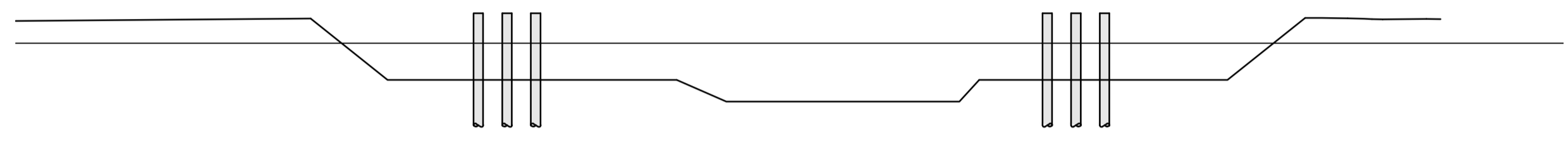

STAGE 1
 • DEMOLISH EXISTING LONGBIRD BRIDGE SUPERSTRUCTURE
 • INSTALL TEMPORARY SILT SCREENS
 • DEMOLISH EXISTING LONGBIRD BRIDGE SUBSTRUCTURE
 • PRE-EXCAVATE FOR FOUNDATIONS
 • DRIVE TUBULAR PILES

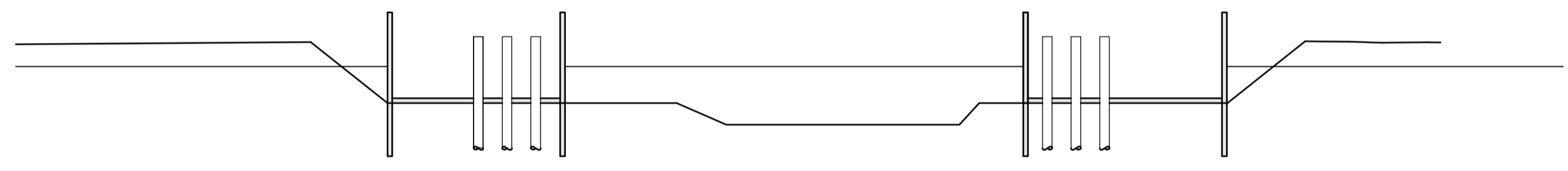

STAGE 2
 • INSTALL TEMPORARY COFFERDAM & DRIVE PERMANENT SHEET PILES
 • EXCAVATE COFFERDAM
 • POUR TREMIE CONCRETE PLUG
 • DEWATER COFFERDAM

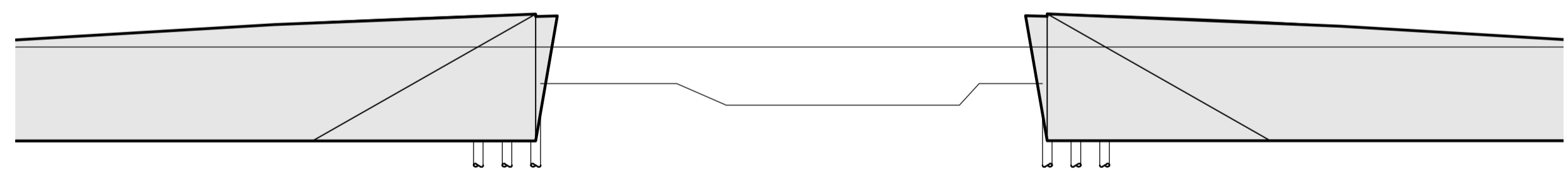

STAGE 3
 • CUT-OFF TUBULAR PILES
 • CONSTRUCT NORTH & SOUTH ABUTMENTS AND NORTH & SOUTH WING WALLS
 • CONSTRUCT ROCK EMBANKMENTS
 • REMOVE TEMPORARY COFFERDAM & SILT SCREENS
 • CUT DOWN PERMANENT SHEET PILES.

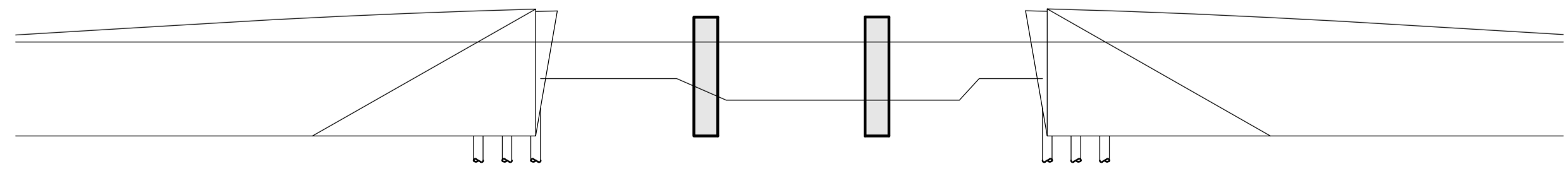

STAGE 4
 • CONSTRUCT TEMPORARY PIERS.

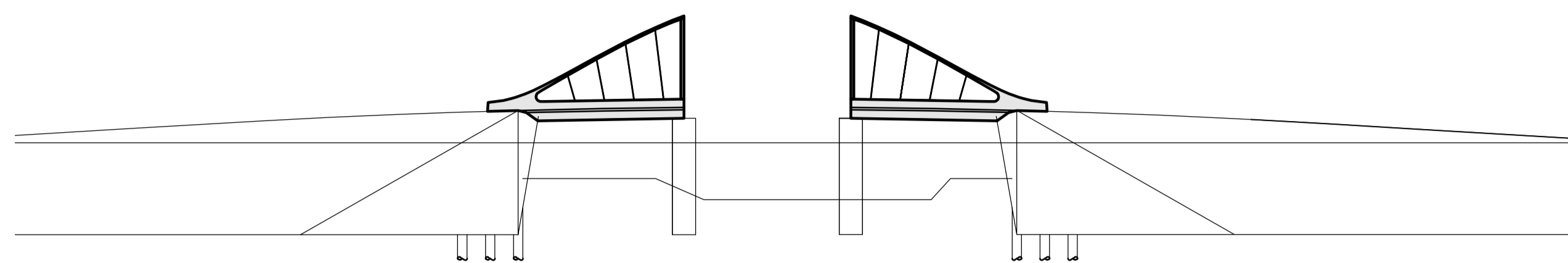

STAGE 5
 • ERECT NORTH & SOUTH BIFURCATION SECTIONS COMPLETE WITH TEMPORARY TOP CHORD PROPS.
 • SUPPORT ON TEMPORARY PIERS.
 • PROVIDE TEMPORARY LONGITUDINAL RESTRAINTS TO BIFURCATION SECTIONS AT ABUTMENTS

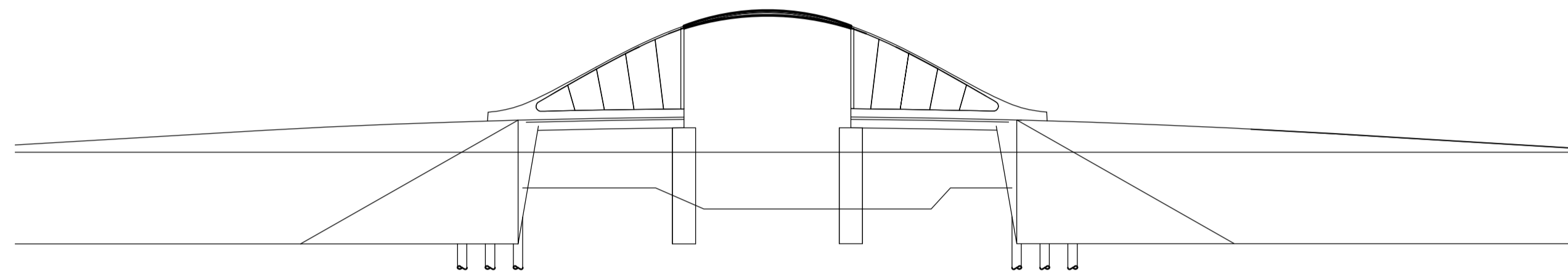

STAGE 6
 • ERECT TOP CHORD CLOSURE PIECE.

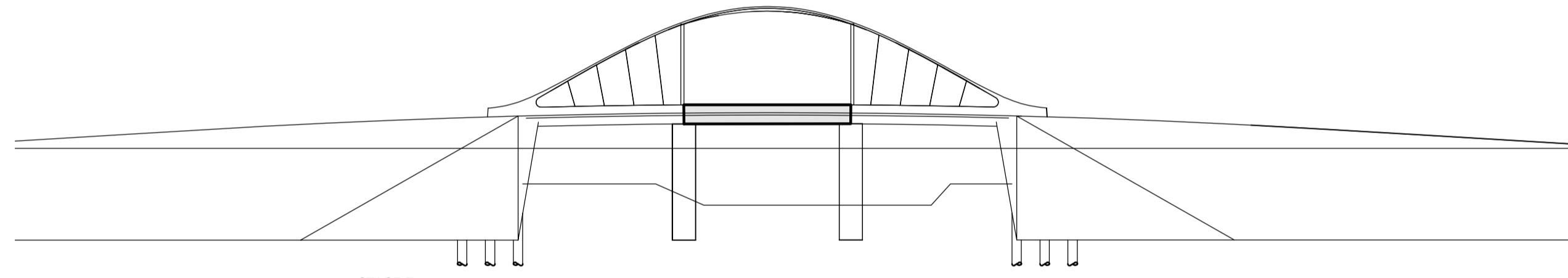

STAGE 7
 • ERECT BOTTOM CHORD/DECK CLOSURE PIECE.

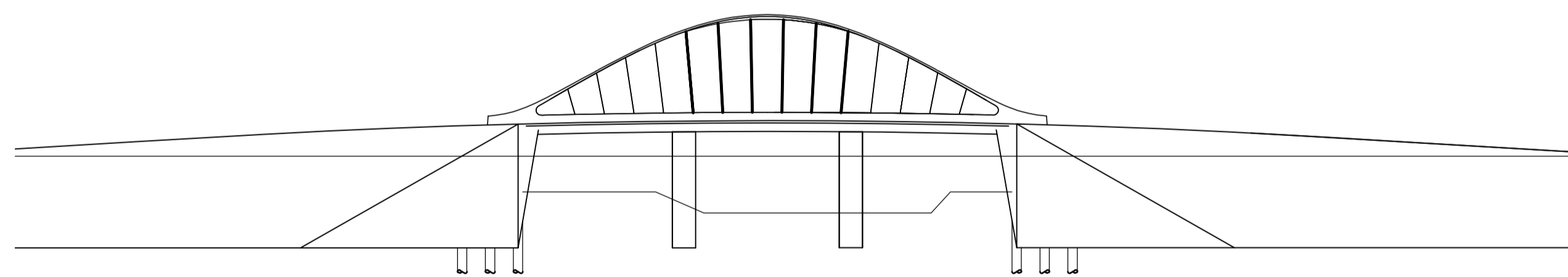

STAGE 8
 • INSTALL REMAINING ARCH HANGERS.
 • REMOVE TEMPORARY TOP CHORD PROPS.
 • REMOVE TEMPORARY LONGITUDINAL RESTRAINTS AT ABUTMENTS
 • CAST REINFORCED CONCRETE DECK SLAB (CASTING SEQUENCE TBC)

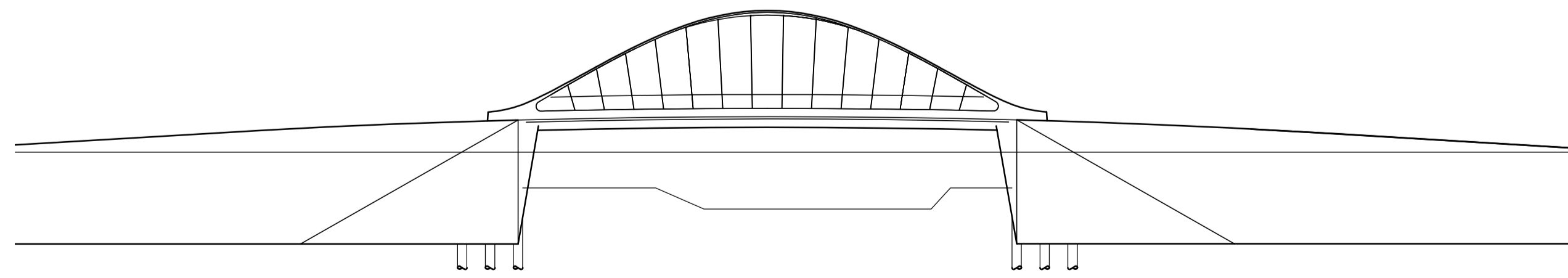

STAGE 9
 • REMOVE TEMPORARY PIERS.
 • APPLY DECK SURFACING.
 • INSTALL FINISHES.
 • DISMANTLE TEMPORARY BRIDGES & MAKE GOOD THEIR ABUTMENTS & APPROACH EMBANKMENTS TO CLIENT REQUIREMENTS

P01	PRELIMINARY	30/11 2018	CAB JFRW	SPT
Rev	Description	Date	By Chk	App

PRELIMINARY



REPLACEMENT OF
 SWING BRIDGE & LONGBIRD
 BRIDGE, BERMUDA



Knight Architects



LONGBIRD BRIDGE REPLACEMENT
 APPROVAL IN PRINCIPLE
 CONSTRUCTION SEQUENCE

Project No: 1620003502	Scale (B1): AS SHOWN	Drawn: CAB	Date: NOV.2018
Drawing No: 3502-RAM-LB-XX-DR-CB-30011		Rev: P01	

Rev P02

**APPENDIX 5
GEOTECHNICAL REPORT – HIGHWAY STRUCTURE SUMMARY
INFORMATION**

**GEOTECHNICAL REPORT
HIGHWAY STRUCTURE SUMMARY INFORMATION**

STRUCTURE NAME		CHAINAGE and OS Grid Reference								Comments
Longbird Bridge Replacement		554153.13m E 139766.18m N								
STRUCTURE TYPE		AIP Ref No								
Fixed Single Span Bridge		3502-RAM-LB-XX-RP-CB-30001								
DESIGN LIFE										
75 Years										
RELEVANT TRIAL HOLES										
BH101, BH102										
<i>(Report: Geotechnical Investigation for Two Bridges in Bermuda Islands: Longbird and St. George's Bridge, Final Report, October 2018)</i>										
Strata Thickness										
Borehole		Thickness of Stratum (m)								
		Fill Material	Coralline Deposits	Clayey Silt Design Layer			Coralline Deposits	Silty Clay	Weathered Basalt/Basalt Breccia	Unweathered Basalt/Basalt Breccia
Sandy Silt	Organics			Silty Clay						
Longbird Bridge	BH101 (North Abutment)	0.7	13.2	-	-	2.1	2.4	5.1	6.5	Extent not proven
	BH102 (South Abutment)	1.5	10.8	5.9	3.3	4.5	2.5	-	5.0	Extent not proven
PREVIOUS GROUND HISTORY										
<p>The historic ground use adjacent to the site is that of an airport development found on reclaimed land but more locally, an existing bridge structure.</p> <p>Previous ground investigations have been undertaken on and around the site:</p> <ul style="list-style-type: none"> • Geotechnical Investigation for proposed new apron and widening of existing taxiway LF Wade International Airport (2016) • Preliminary Geotechnical Assessment New Grotto Bay/Castle Harbour Crossing Bermuda (2007) • St George's Town Cut Project, Geotechnical Data Report (2015) 										
GROUNDWATER										
Groundwater levels are assumed to be equivalent to that of sea level.										
EARTH PRESSURE VALUE k_0^*		Coralline Deposits				Silty Clay/Clayey Silt				
		0.48				0.64				

SOIL PARAMETERS										
Stratum	Bulk Density, γ (kN/m ³)	Strength Parameters			UCS (MPa)	Hoek Brown				
		Undrained Shear Strength, c_u (kN/m ²)	Effective Shear Strength Parameters Angle of Friction, Φ' (°)			mb	a	s		
			Effective angle of shearing resistance, e, Φ' (°)	Effective cohesion (kN/m ²)						
Fill	18.0	20								
Coralline Deposits	16.0		34	0						
Clayey Silt	19.0	70	21	0						
Silty Clay	19.0	70	21	0						
Weathered Basalt	21.3		36	181	3.2	3.383	0.51	0.002		
Basalt	23.0		62	404	30	5.99	0.5	0.01		

PILE DESIGN											
Structure Element	Founding Stratum	Founding Rock Head Level (mOAD)	Pile Cap Head Level (mAOD)	Pile Toe Level (m AOD)	Pile Length (m)	Pile Diameter (mm)	Ultimate Bearing Resistance (kN)	Pile Tensile Load (kN)	Pile Compressive Load (kN)		Notes
									SLS	ULS (Set C)	
Northern Abutment (BH101)	Weathered Basalt	-24.6	-1.1	-27.1	26.0	900	6437	-1000	2000	2500	2.5 m rock socket
Southern Abutment (BH102)	Weathered Basalt	-29.6	-1.1	-31.6	30.5	900	6649	-1000	2000	2500	2 m rock socket

Pile type.....Steel Tubular - Driven
Criteria for selecting pile toe level..... Founding Strata Strength/Stiffness
Allowance for negative skin friction within design.....Potential for settlement of supporting soil due to placement of rock armour and abutment fill to be considered in detailed design

Continued overleaf

SETTLEMENT	
------------	--

Structural Element	Founding Level (m AOD)	Immediate Settlement (mm)	Total Settlement (mm)	Time for 90%	Settlement Remaining at Completion
Northern Abutment (BH101)	To be completed on receipt of design loads				
Southern Abutment (BH102)	To be completed on receipt of design loads				
GROUND MOVEMENTS					
Associated Earthworks	Settlement due to Embankment loading	Heave due to Cutting Excavation	Subsidence Due to Mineral Extraction	Flowing Water	Other
Cause of Movement	Not Applicable				
Maximum Movement (mm)					
Measures to Deal with Movement					